



All Web UniPlus
Stone and Clod Separator
(from 2019)

Standen Engineering Limited.
Hereward Works,
Station Road, Ely,
Cambridgeshire.
CB7 4BP
England.

Tel: 01353 661111

www.standen.co.uk

Fax: 01353 662370

EU & UKCA Declaration of Conformity

According to the Machinery Directive 2006 / 42 / EC
& The Supply of Machinery (Safety) Regulations 2008

Manufacturer: Standen Engineering Limited Station Road, ELY Cambridgeshire CB7 4BP England

We declare that the product, described below, meets the requirements of the above mentioned directive and has been assessed against and complies with the essential safety requirements application as specified in the Standards listed here.

Model	Uniplus - Web
Serial No.	UNPW.....

British Standards used in the implementation of this certificate

BS EN ISO 12100-1
BS EN ISO 12100-2
BS EN ISO 13857

Place of Issue: Standen Engineering Limited, Station Road, Ely,
Cambridgeshire, UK



M R Gammon - Technical Manager
For Standen Engineering Limited

IMPORTANT

This operator's handbook should be regarded as part of the machine. Suppliers of both new and second-hand machines are advised to retain documentary evidence that this handbook was supplied along with the machine.

On installation of the machine (i.e. starting off in the field), the New Machine Installation Record Card should be completed by the dealer/distributor and be countersigned by the customer. The document is proof that the correct procedures have been followed.

The New Machine Installation Record Card should be returned to Standen Engineering Limited within 7 days of installation. Failure to do so may invalidate the machine warranty.

On delivery check that the machine is as ordered and has not been damaged in transit. Please report any shortfall to your Standen dealer.

The contents of this handbook, although correct at the time of publication, may be subject to alteration by the manufacturers without prior notice.

Standen Engineering Limited operates a policy of continual product development. Therefore, some illustrations and/or text within this publication may differ from your machine.

The copyright of this handbook is the property of Standen Engineering Limited, Hereward Works, Station Road, Ely, Cambridgeshire. CB7 4BP. This handbook is issued on the condition that it must not be used, copied or exhibited without their written permission.

INTRODUCTION

Introduction to the Handbook	1.1
Warranty	1.1
Replacement Parts	1.2

SAFETY PRECAUTIONS

Safety	1.3
HSE Information Sheet	1.5

INSTALLATION

Machine Description	1.7
Tractor Suitability	1.7
Tractor Wheel Settings	1.7
Drawbar	1.7
PTO Shaft	1.8
Hydraulic Connection	1.9
Open/Closed Centre Hydraulics	1.9

OPERATION

Wheel Settings	1.11
Automatic Depth Control	1.12
Setting the Automatic Depth Control	.13
Discs	1.14
Shares	1.14
Web Separation Area	1.14
Draper Web	1.15
Cross Conveyor	1.15
Stone Elevator (optional)	1.16
Boulder Box (optional)	1.16
Vari-Flow (optional)	1.16
Braked Axles (optional)	1.16
Hydraulically Damped Drawbar (optional)	1.17
Electrical Control System	1.18

MAINTENANCE

Lubrication	1.22
Drive Belt Maintenance	1.23
Electrical System Maintenance	1.23
Hydraulic System Maintenance	1.23
Residual Hydraulic Pressure Dump Procedure	1.24
Split Web Drive Sprockets	1.24
Daily Maintenance	1.25
Weekly Maintenance	1.25
Annual Maintenance	1.25
Out of Season Storage	1.26

SPECIFICATIONS

Machine Dimensions	1.27
Machine Weight	1.27
Technical Data	1.27
Wheel Track Settings Diagram	1.28

CIRCUIT DIAGRAMS

Hydraulic Circuit	1.30
ELMR190 Output Information	1.31
CAN-bus Distribution Board	1.32
ESMR193 Connections	1.33
Cross Conveyor Relay & Sensor Information	1.34
Automatic Stop Vari-Flow When Digger Is Lifted	1.35

Introduction to the Handbook

This handbook provides the information for the operation, adjustment and maintenance of your Standen All Web UniPlus stone and clod separator. To enable you to achieve the best results from the machine, the manufacturer recommends that you read the handbook thoroughly prior to using the machine for the first time.

Record below the details of your machine.

Dealers name.....

Address.....

.....

Telephone number.....

Machine serial number.....

Date purchased.....

Date started work.....



This symbol indicates important safety messages within this handbook. When you see this symbol, be alert to the possibility of injury to yourself or others and/or damage to the machine and carefully read the message that follows.

Throughout this handbook the terms 'front', 'rear', 'left-hand' (LH) and 'right-hand' (RH) are derived from the tractor driver's position facing forward in the normal direction of travel.

Adjustments to the machine may have to be made singly or in combination according soil conditions. Always allow the machine to settle to a new setting before making further adjustments.

Recommended lubrication and maintenance instructions are included in this handbook and if followed will help to keep the machine in a safe working condition.

Warranty

Should the machine suffer any faults or defects within the warranty period, please contact your dealer. The warranty shall be effective only if the dealer is informed of any such defect as soon as practicable upon discovery.

Replacement Parts

Recommended replacement parts are designed for your machine and have the full backing of the warranty. Only when recommended parts are used can responsibility be considered under the terms of the warranty.

The rear of this handbook contains lists of spare parts available through your Standen Agents. Each illustration shows a complete unit or assembly in exploded form. Standen's policy of continual product development means that components or even complete assemblies are redesigned from time to time. Where possible the modifications are shown in the remarks column.

The first printing of each page in the spare parts section is identified as issue 1 at the foot of the page. When a complete unit or assembly has been redesigned the appropriate pages are revised and printed as issue 2. The revised pages are filed behind the existing issue so that a complete modification history is gradually built up. When using an illustration and parts list it is essential that both are of the same issue.

Always quote the full serial number of your machine when ordering spare parts.

Safety

The Standen UniPlus has been designed to comply with current Safety Regulations. However, as with all machinery there will be inherent dangers whilst operating and carrying out maintenance on the machine. The following list of precautions should therefore be brought to the attention of all persons operating and working on the machine. The list is not exhaustive. All machinery is potentially dangerous and great care must be exercised by the operators at all times. Standen Engineering Limited will not accept liability for damage or injury caused by their products except when such liability is specifically imposed by English statute.



The machine must never be operated by untrained personnel or children.

Always check that the machine has been correctly mounted to the tractor before setting off on operations and the stabilizers are correctly set.

Never set machinery in motion before ensuring that everyone in the vicinity is aware of your intentions.

Never allow children or animals in the vicinity where machines are working and never allow anyone to ride on the machine.

In dry, dusty conditions it is prudent to use a tractor with an enclosed cab.

Never attempt to fit drive chains or drive belts to the machine while the drive sprockets or pulleys are in motion.

Normal safe working procedures should be adopted at all times. Reduce speed when transporting the machine on sloping ground.

Do not work on ground where there is a possibility of overturning or across steep slopes.

The working area should be kept clear and free of obstructions at all times. Be alert for hidden obstructions. Should the machine hit an obstruction, stop and check for damage before proceeding.

Wear substantial or proper safety footwear. Avoid loose clothing near moving parts. Wear gloves when handling the implement or parts with sharp edges.

Before carrying out any work on the machine, lower the machine to the ground, switch off the tractor engine, apply the handbrake, remove the ignition key and disconnect the PTO shaft.



Before using the conveyor fold external switches, disengage PTO, set tractor gearbox to 'neutral' (or park lock), apply handbrake and set engine speed to idle. Ensure everyone in the vicinity is aware of your intentions.

Never reverse or turn unless the machine is in the raised position.

All guards, covers, warning transfers and safety devices must be correctly fitted and operable at all times.

Inspect the machine on a regular basis and replace damaged or worn parts as necessary.

Inspect the machine for damage after use. Rectify as required.

Never operate the machine in a state of disrepair.

Only transport the machine at a speed suitable to the prevailing conditions. Be aware of the weight and overall length of the machine at all times.

Before working on the machine, all free moving parts should be locked to prevent them moving.

Regularly lubricate the machine as per the operator's handbook and check the tightness of all nuts and bolts, particularly those securing the rotor blades/tines.

Always use mechanical or additional help when lifting heavy parts.

Regularly check hydraulic hoses for chafing or damage and replace as necessary.

Care must be taken when carrying out any work on the hydraulic system. Even when stopped and disconnected from the tractor, residual pressure will exist within the hydraulic system. Therefore, before commencing any work on the hydraulics ensure that the system is free of residual pressure by carrying out the 'pressure dump' procedure outlined within this handbook.

Before transporting the machine on a public road, set the hydraulic levelling to its lowest position, fully raise the shares, lock the cross conveyor into the transport position, set the drawbar and steering to the straight-ahead position and switch off the control box to avoid inadvertently operating any machine services. Finally, ensure road lights are clean and in good working order.

Safety is the responsibility of the persons working with this machine. Think "safety" at all times. Read and remember the contents of this handbook.

HSE information sheet

Working safely near overhead power lines

Agriculture Information Sheet No 8 (rev)

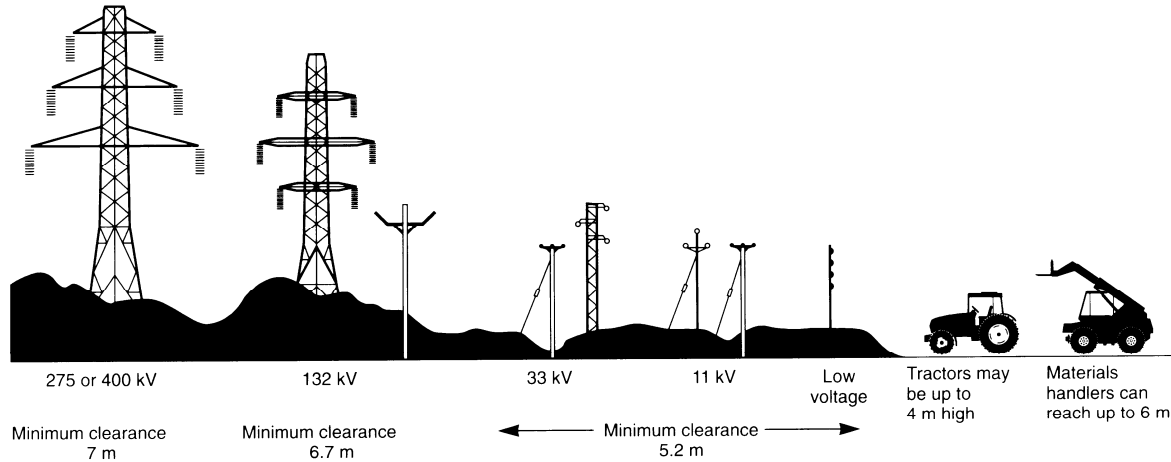
**Be aware of line heights****Introduction**

About five people are killed every year in accidents involving overhead power lines during agricultural work. Machinery (eg combines, tipping trailers and loaders); equipment (eg irrigation pipes and ladders); and activities (eg stacking) are often involved. Contact with the lines does not need to be made. Electricity can flash over when machinery or equipment gets close to overhead lines.

Most incidents involve high-voltage lines supported on wooden poles, but the dangers of other power lines cannot be ignored.

This information sheet outlines the steps you can take to reduce the risks when working near overhead power lines. Remember the Electricity at Work Regulations 1989 apply to work activities carried out near power lines.

Planning precautions

Consult your local electricity company. They will provide free information and advice about precautions and safe working procedures which can be followed near power lines.

Find out the maximum height and maximum vertical reach of your machines and those used by contractors.

Find out the routes of **all** overhead lines on your land or near your boundaries. Mark them on the farm map. The electricity company will give you this information.

Make sure you have information about all the lines on your land - if not, contact the owners of those lines.

The farm map can be used as a reference when planning cropping or other work, instructing machine operators and contractors, or buying new equipment.

In cases where there is a significant risk area, it is sensible to discuss the following measures with the electricity company:

- **access:** creating alternative access points and routes - this is often the cheapest option;
- **divert lines:** benefits can arise from burying lines or changing routes - an option particularly suited to farmyards;
- **barriers and goal posts:** by erecting goal posts and barriers, machines which have to pass beneath lines can be limited to a safe height - an option especially suited to gateways and tracks.

Working safely

Key elements of safe systems of work are:

Training

Everybody who works near overhead power lines with a machine or equipment needs to know what the dangers of overhead lines are and the precautions to follow.

Visitors

Contractors are at risk when they work on farms where overhead lines are present. Make sure they know where the lines are and tell them the precautions they need to take. Routes can be marked with safety signs to warn all visitors of the dangers.

Use of machinery

Accidents can be avoided if the following operations are **not** carried out within a horizontal distance of at least 9 m from power lines on wooden poles or at least 15 m of lines on metal towers:

- stacking bales or potato boxes;
- folding sprayer booms;
- tipping trailers or lorries;
- operating materials handlers;
- working on top of combines or other high machinery.

Risks can be reduced by:

- using sprayers with horizontally folding booms;
- taking care not to damage poles and stays;
- making sure machinery can operate safely near any overhead lines;
- fitting shorter radio aerials to high machines so they cannot cause danger;
- carrying irrigation pipes horizontally using two people and not storing pipes near power lines.

EMERGENCY ACTION IN THE EVENT OF AN ACCIDENT

- **Never touch an overhead line - even if it has been brought down by machinery, or has fallen. Never assume lines are dead.**
- **When a machine is in contact with an overhead line, electrocution is possible if anyone touches both the machine and the ground.**
- **If you need to get out to summon help or because of fire, jump out without touching any wires or the machine. Keep away.**
- **Get the electricity company to disconnect the supply. Even if the line appears dead, do not touch it - automatic switching may reconnect the power.**

Further advice

For further advice and information contact your local electricity supply company. You can also get advice from the Farm Energy Centre, National Agricultural Centre, Stoneleigh Park, Warwickshire CV8 2LS (Tel: 01203 696512). To obtain the latest edition of their handbook *Safe use of electricity in farming and horticulture* (FEC 2100: 3rd edition 1992), send them a cheque for £2.50 made payable to Farm Energy Centre.

Further reading

Avoidance of danger from overhead electrical lines GS 6 (rev) HSE Books 1991 ISBN 0 11 885668 5

Farm Electric *The safe use of irrigators and slurry guns near overhead electric power lines* Electricity Association Technology Ltd. Available free from the Farm Energy Centre, National Agricultural Centre, Stoneleigh Park, Warwickshire CV8 2LS

Memorandum of guidance on the Electricity at Work Regulations 1989 HSE Books 1989 ISBN 0 11 883963 2

Management of health and safety at work. Management of Health and Safety at Work Regulations 1992. Approved Code of Practice HSE Books 1992 ISBN 0 7176 0412 8

An HSE video called *Shock horror* is available for purchase or hire from CFL Vision, PO Box 35, Wetherby LS23 7EX (Tel: 01937 541010).

HSE priced and free publications are available by mail order from HSE Books, PO Box 1999, Sudbury, Suffolk CO10 6FS. Tel: 01787 881165 Fax: 01787 313995.

HSE priced publications are also available from good booksellers.

For other enquiries ring HSE's InfoLine Tel: 0541 545500, or write to HSE's Information Centre, Broad Lane, Sheffield S3 7HQ.

HSE home page on the World Wide Web:
<http://www.open.gov.uk/hse/hsehome.htm>

This leaflet contains notes on good practice which are not compulsory but which you may find helpful in considering what you need to do.

This publication may be freely reproduced, except for advertising, endorsement or commercial purposes. The information is current at 6/97. Please acknowledge the source as HSE.

Machine Description

The Standen All Web UniPlus is designed to remove stones and clod from the soil to improve cultivation. The stones and clod are deposited in the wheelings between the beds, while the larger stones are transported to a boulder box (if fitted) and removed from the field. Working widths are 1500mm, 1600mm or 1700mm.

Tractor Suitability

The power requirement for the All Web UniPlus is 110 bhp minimum.



The tractor must be of a suitable size to lift the implement safely. This may entail the fitting of front weights to counterbalance the machine when in the raised position.

Tractor Wheel Settings

Both front and rear tractor wheels must be set to run down the centre of the wheelings and must span the bed being lifted. Consult your tractor handbook for the correct procedure for setting the tractor wheels.



When carrying out wheel adjustments, always place the jack on firm ground under a solid part of the tractor. Before removing a wheel, place a stout support under the tractor frame in case the jack should become dislodged.

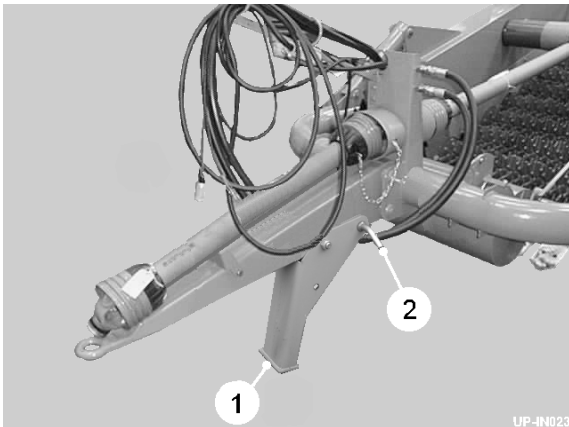

Fig 1

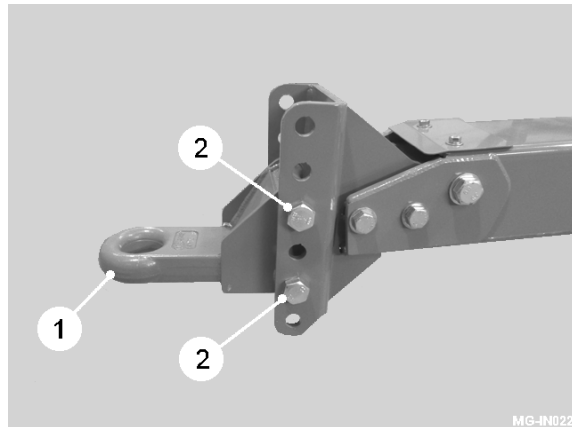

Fig 1a

Drawbar

The stand (item 1, fig 1) is provided so that the machine is held at a suitable height for safe coupling to the tractor pick-up hitch. On machines fitted with an adjustable drawbar eye (item 1, fig 1a), reverse the tractor up to the machine aligning the drawbar and pick-up hitch. Measure the height of the tractor hitch hook from the ground and adjust the drawbar eye to the same height by removing the two mounting bolts (item 2, fig 1a) and repositioning them into a different set of holes. The drawbar eye can be turned upside down to achieve higher settings.



Always ensure the stand is positioned on firm, level ground to avoid the machine sinking or sliding whilst stood. Both wheels should be chocked front and rear before removing from tractor. Do not store the stand separately from the machine. You never know when it will be needed.

When the machine has been securely attached to the tractor, the jack stand can be folded back into the stored position by removing the anchor pin (item 2, fig 1), rotating the stand and then securing it with the anchor pin.

PTO Shaft

The machine is designed to operate with the tractors 540 rpm, 6 spline, 1 3/8" PTO output shaft.



PTO speeds greater than 540 rpm will cause damage to the system and if exceeded may invalidate the warranty.

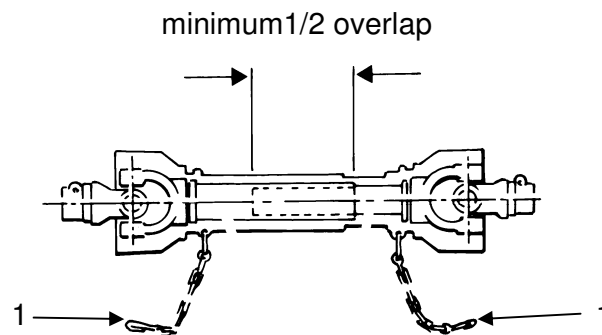

Fig 2

Fit the two halves of the PTO shaft onto their respective drive shafts on the machine and tractor. Check the shaft length by turning the tractor fully in both directions with the machine in its working position while attached to the tractor's pick-up hitch. Ensure the sliding tubes, when fully extended, have an overlap at least half the closed length (see figure 2). Ensure that the ends of the sliding tubes when at the shortest point are not in contact with other parts of the PTO shaft. If necessary, shorten both tubes and guards equally to achieve end clearance at the minimum length position.

Make sure that the drive shaft is fitted correctly and that the lock pins are engaged.

All the parts of the PTO shaft, especially the guards, must be kept in good order. Check regularly that the guard is undamaged and fully protects the whole of the shaft, and that both the guard and the shaft will telescope freely.

If it is possible to engage the inner and outer parts of a drive in more than two positions circumferentially then make sure that the universal joint yokes are correctly aligned.

Check that when in the continuous working position, the drive shaft is not at an angle of more than 20° from the PTO centre line. The angle between the drive shaft and the input and output shafts should be equal.

Ensure that the safety chains (item 1, fig 2) used to prevent the guards from turning, are fixed to the tractor and implement in such a way that they will not be stretched when the drive shaft is at maximum articulation. When disconnected from the tractor, position the PTO shaft on the drawbar PTO rest as shown in figure 1.

Hydraulic Connection

The feed and return hoses from the machine must be connected to the respective external service connections of the tractor hydraulic system. Both feed and return hoses have labels with arrows indicating the direction of oil flow. Connect the load sense hose to the tractor L/S outlet.

The tractor hydraulic system must be set to constant pumping. Consult the tractor manufacturers handbook for details about connecting external equipment to the hydraulic system and hydraulic pump settings.

Required oil flow from tractor system	minimum	70 ltr/min
(Set to constant pump)	maximum	100 ltr/min
(For flows greater than 100 ltr/min consult your officially appointed Standen dealer)		

There must no restriction in this return oil. Ensure that there is a full flow return, or even better return straight back into the tractor gearbox. Consult your tractor handbook or dealer for further information.

Open / Closed-Centre Hydraulics

Two types of hydraulic system are currently in use by tractor manufacturers, OPEN-CENTRE or CLOSED-CENTRE. Consult the tractor manufacturers handbook or dealer for further information.

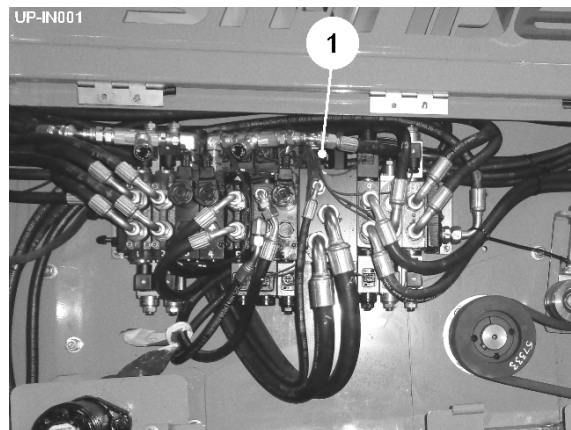

Fig 3

The main hydraulic valve bank incorporates an adjustable screw (item 1, fig 3) which enables easy changing from closed-centre to open-centre.

Closed-centre system, turn the screw clockwise until fully closed.

Open-centre system, turn the screw anticlockwise until fully out.

Load-sensing system turn the screw clockwise until fully closed.

Wheel Settings

The machine wheels must be set for work in a specific bed width. The wheels should be set to match the tractor wheels. See 'wheel track settings' diagram in the specifications section of this handbook.

Each wheel is carried by a wheel leg pillar (item 2, fig 4) The pillars have a top and bottom flange plate containing a series of fixing holes. Moving the pillars in or out adjusts the wheel centres to suit the selected bed width. Both wheel legs must be set to the same hole positions so that the wheels remain symmetrical about the centreline of the machine. Lifting equipment must be used when setting the wheels.



Before commencing axle adjustment, ensure adequate jacks, axle stands of minimum 2500 kg capacity, wheel chocks and suitable lifting equipment are available.



It is important that the machine is correctly fitted to the tractor and that the tractor handbrake is applied whilst axle adjustments are made.

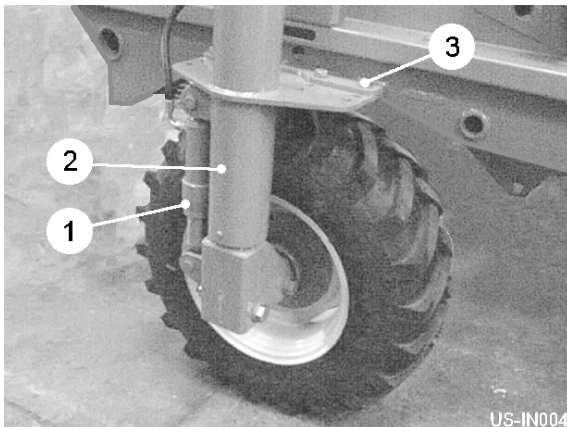

Fig 4

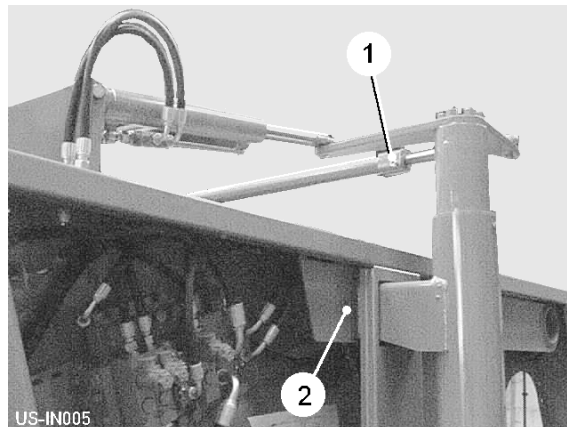

Fig 5

Place chocks at the front and rear of the opposite side wheel to the one being adjusted. Jack up the machine and place an axle stands under the chassis and lower the jack to allow the axle stands to take the weight of the machine.

Release the track rod locking bolt (item 1, fig 5) and remove the flange plate mounting bolts (item 3, fig 4 & item 2, fig 5). Using lifting equipment, carefully slide the leg pillar to the required position. Refit the mounting bolts (item 3, fig 4 & item 2, fig 5) through the relevant hole in the flange plates. Repeat the procedure for the opposite wheel. Finally, set the track rod to the correct length and secure using the locking bolt. Ensure all nuts and bolts are fully tightened after adjustments have been completed.

Automatic Depth Control

The machine is fitted with an automatic depth control system which ensures an even depth of soil in the finished bed. The depth roller (item 1, fig 6) runs on top of the preformed bed following the contours. The depth roller is linked to a depth sensor (item 1, fig 7) and via the hydraulic valve bank actuates the depth rams (item 2, fig 7). A depth indicator is fitted to the RH depth ram giving the operator a visual indication of the action of the sensing system. The ram stop brackets (item 3, fig 7) must be set in the position shown before commencing work.

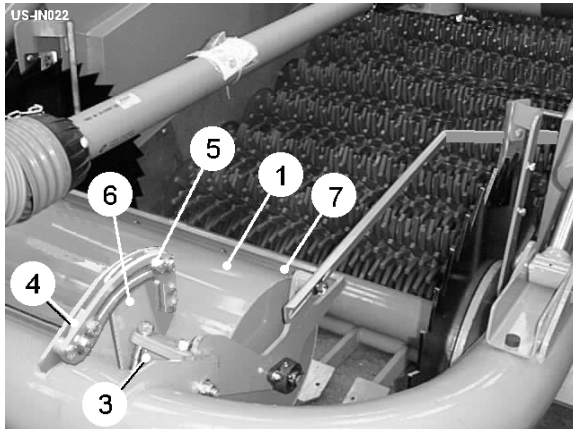

Fig 6

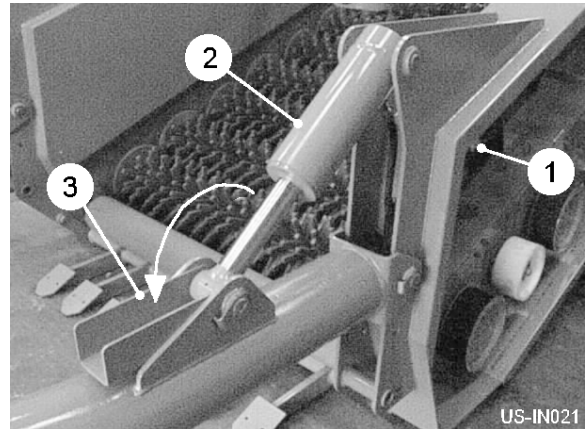

Fig 7

The depth roller frame pivots on rubber torsion mountings (item 3, fig 6). By adjusting these mountings it is possible to adjust the amount of pressure the roller exerts on the soil. The pressure setting needs to be made with the machine in work so that the relative working position of the roller and shares is correct.

1. Release the front and rear quadrant stops (item 4 & 5, fig 6) on both sides of the roller unit.
2. Lower the machine into work until the shares are at the required digging depth.
3. Slide the front stops (item 4, fig 6) up against front edge of the quadrant arms (item 6, fig 6) and lightly secure.
4. Raise the machine slightly, causing the quadrant arms (item 6, fig 6) to rotate backwards away from the front stops (item 4, fig 6), and then reposition the front stops up against the quadrant arms and secure fully. The higher the machine is raised prior to repositioning the front stops, the greater spring pressure will be.
5. Lower the machine back into work and set the rear stops (item 5, fig 6) approximately 15mm away from the rear of the quadrant arms (item 6, fig 6). This gap allows the depth roller to drop slightly, maintaining digging depth, when the tractor rides out of the bed onto the headland.

The scrapers (item 7, fig 6) should be set as close to the roller as possible without fouling it.



Before transporting the machine on the road, reset the ram stop brackets (item 3, fig 7).

Setting the Automatic Depth Control

1. Set the machine into work and adjust the digging depth using the 'Digger Share Raise/Lower' switch on the control box.
2. Note the reading on the RH depth ram indicator (item 1, fig 7a).
3. Lift the machine out of work and then switch on the auto-depth system. The LED will illuminate when the system is activated.
4. Turn the depth control dial until the depth ram indicator (item 1, fig 7a) aligns with the noted reading.
5. Note the reading on the control box display (Target Depth: -mm). This figure together with the reading on the ram depth indicator will represent the initial depth setting. To increase the depth turn the depth control dial clockwise. To decrease the depth turn the dial anticlockwise.

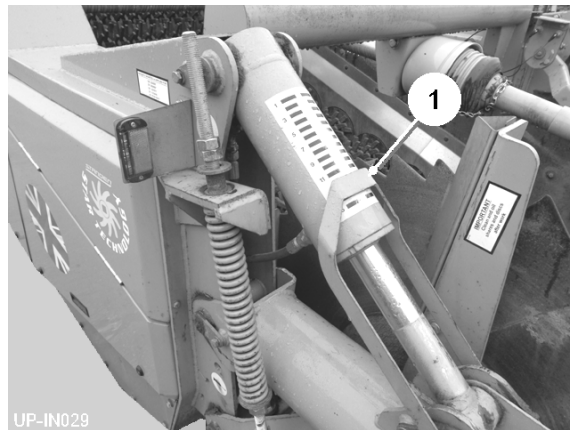

Fig 7a

Discs

The discs (item 1, fig 8) cut and contain the soil while feeding it over the shares onto the stars. The disc width setting is adjusted by loosening the two mounting bolts (item 2, fig 8) and repositioning the disc mounting (item 3, fig 8) using the adjuster screws (item 4, fig 8). The pressure setting of the discs is set on the springs (item 5, fig 8). The spring pressure should be sufficient to keep the disc turning in the soil while at the same time allow it to rise up over any obstructions. Spring pressure is increased/decreased by raising/lowering the bottom spring rod locknuts (item 6, fig 8). Maximum disc height is limited by the depth stop (item 7, fig 8).

As the disc scrapers (item 8, fig 8) wear, they should be adjusted closer to the disc. Position the scrapers until just clear of the disc surface and retighten.

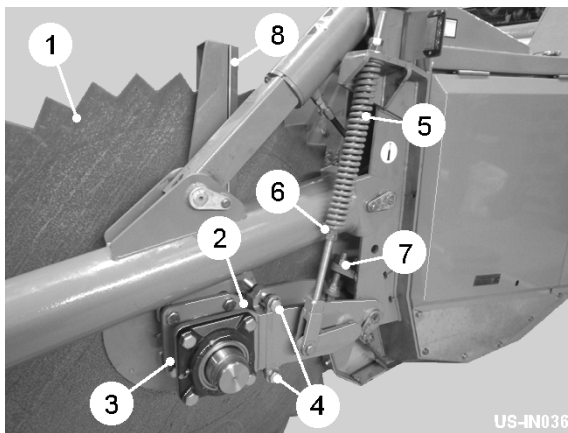

Fig 8

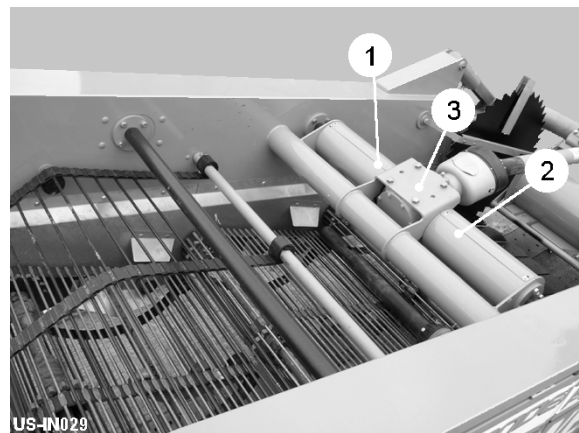

Fig 9

Shares

The standard machine is fitted with a 7-piece share blade arrangement. The outside blades come in two different widths, standard and wide, to cope with the variety of bed widths. In general the standard outer blade is fitted for the narrower bed widths while the wide outer blade is fitted for the wider bed widths. If blade widths are altered then the disc positions will have to be adjusted to suit. Single piece full width share blades are also available for use in particular soil conditions.

Web Separation Area

The separation area is made up of the 1st, 2nd, 3rd and 4th webs. The webs are available in a range of different pitches. The 1st, 2nd and 3rd webs are exactly the same length making them interchangeable and thus enabling the grower to carry less stock.

Note: When changing webs, ensure that each web is fitted with its centre band offset from the adjacent web. This will prevent soil being carried from one centre band to the next.

Each web is driven via a toothed belt. For adjustment see the maintenance section of this handbook. The webs are protected by two slip clutches (item 1 & 2, fig 9) located under the guards either side of the main gearbox (item 3, fig 9). The slip clutches are preset at the factory to 1350 Nm.

Draper Web

The draper web (item 1, fig 10) mounted above the 4th web assists separation. In work, the web is raised/lowered using the control box switch marked 'draper web'. Lowering the draper web increases the pressure on the 4th web and thus increases the separation. The front and rear sets of damper rollers (item 2 & 3, fig 10) hold the draper web down. Lowering the dampers rollers will increase the pressure exerted on the 4th web. The front and rear damper arms are linked via an adjustable stay located behind the RH rear guard door. The stay enables the operator to manually adjust the height of the damper rollers. Too much pressure or too little height, may cause soil build-up in front of the 4th web.

The initial height of the draper web is set using the ratchet arm (item 1, fig11).

To adjust the height:

1. Release the pressure on the web by fully raising the damper rollers via the control box.
2. Support the weight of the web by holding the ratchet arm (item 1, fig 11).
3. Pull out the plunger (item 2, fig 11) and rotate the ratchet arm allowing the plunger to rest on the slotted plate (item 3, fig 11).
4. Continue to adjust the plate until the plunger relocates into the next slot.
5. Repeat until the correct height is achieved.

Additional height adjustment can be obtained by relocating the shackles (item 4, fig 10) onto a different web bar.

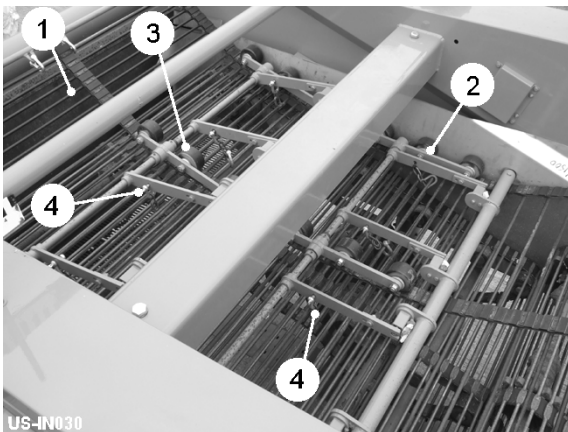

Fig 10

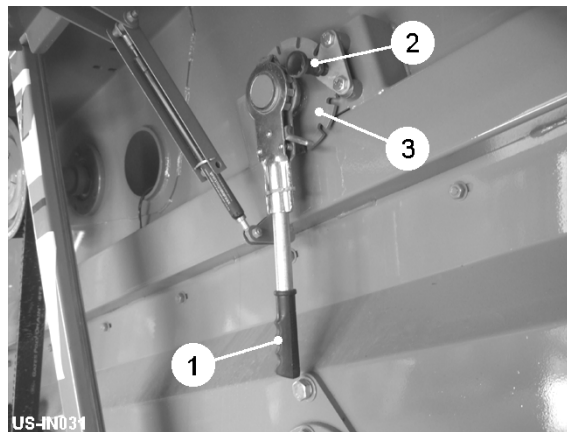

Fig 11

Cross Conveyor

The cross conveyor places the stones and clod into the centre of the designated trench. The speed of the cross web must be coordinated with the amount of traverse (side-shift). Side-shift is controlled by the switches on the control box.

Stone Elevator (optional)

The stone elevator works in conjunction with the cross elevator to transfer the stones into a trailer running alongside.

Boulder Box (optional)

The boulder box is recommended in conditions where many large stones and boulders are encountered and it is advisable to remove them from the field rather than leave them in the trenches between the formed beds. The unit consists of two rows of widely spaced 6 finger stars. The stars allow normal material to fall through onto the cross web while large stones or boulders are transported over the stars into the boulder box. The boulder box can then be emptied at a convenient point.

Vari-Flow Web (optional)

The Vari-Flow web consists of a hydraulically driven web mounted above the 4th web. The web assists the flow of soil and stones in conditions such as on steep slopes. The web assists the flow of soil and stones in conditions such as on steep slopes. Speed is adjusted from the control box. In hilly conditions, the web will assist the waste material over the back of the 4th web rather than through the web because all the soil has been extracted. Too little speed may cause soil to build up in front of the web. On cloddy land, run the web slightly slower than the flow to help break up more of the clod.

Braked Axles (optional)

Connect the hydraulic brake hose to the tractor 'brake service outlet'. The machine brakes will operate when the tractor brakes are applied. Brake shoe wear can be taken up by adjusting the setscrews (item 1, fig 12).

To apply the handbrake, pull the lever (item 1, fig 13) in and out against the ratchet until the brake cables are fully tensioned. To remove the handbrake, pull the lever fully out to release the ratchet mechanism catch (item, 2, fig 13). Finally, push the lever back under the machine for transport. Handbrake cable length is set on the cable adjusters (item 2, fig 12).

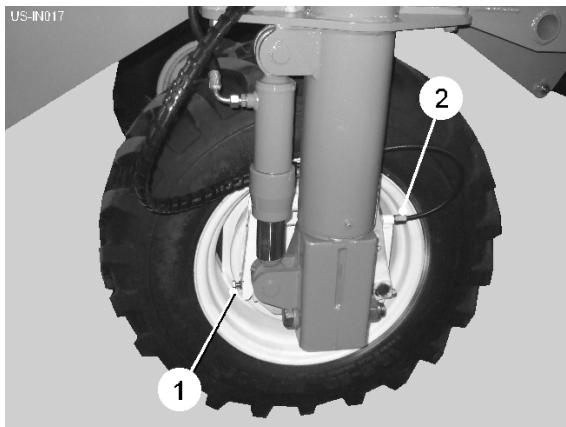

Fig 12

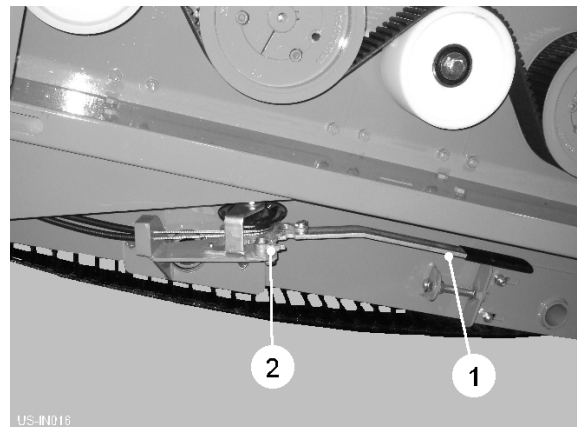

Fig 13

Hydraulically Damped Drawbar (optional)

The hydraulically damped drawbar is fitted to protect the machine when operating in soil conditions where buried obstructions may be encountered. The system consists of a hydraulic cylinder mounted within the drawbar pressurised by an accumulator (item 1, fig 14). The design allows the drawbar to extend by 200mm. After 25mm of movement a proximity sensor triggers the control system which simultaneously lifts the digger unit and stops the cross conveyor and vari-flow. After activation the machine elements have to be restarted using the control box. The drawbar must always be pressurised before commencing work.

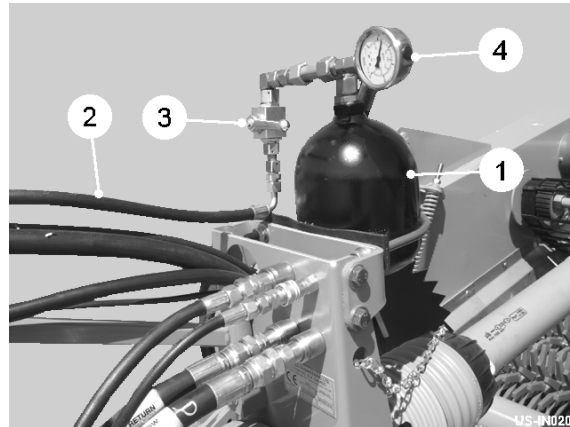

Fig 14

To set the accumulator pressure, connect the hose (item 2, fig 14) to the tractor spool valve and open the accumulator valve (item 3, fig 14). Open the tractor spool valve while closely watching the pressure gauge (item 4, fig 14). When the pressure reaches 65 bar immediately close the spool valve and then close the accumulator valve. If necessary, reduce the pressure slightly using the accumulator valve. The drawbar is now pressurised and ready for operation. If in work, due to differing soil conditions, the initial setting of 65 bar is found to be too low and the drawbar is extending in normal work, increase the pressure setting by increments of 10 bar until the drawbar is static. **DO NOT EXCEED 120 BAR.** If the drawbar is still not functioning correctly when the maximum pressure is reached, consult your Standen dealer for further advice.



Do not carry out maintenance on the drawbar with circuit pressurised. Stop the tractor engine and reconnect the hose to the tractor spool valve. Open the accumulator throttle valve and operate the spool valve to dump the hydraulic pressure within the system.

Electrical Control System

Control for the major functions of the Standen UniPlus are provided electronically by the switches mounted on the in-cab control box (item 1, fig 15) switching the valves on the machine via a CAN-bus control system. The functions can be monitored from the control box display screen (item 2, fig 15). Setting and monitoring can be carried out by following the instructions in the CAN-Bus operating instructions.

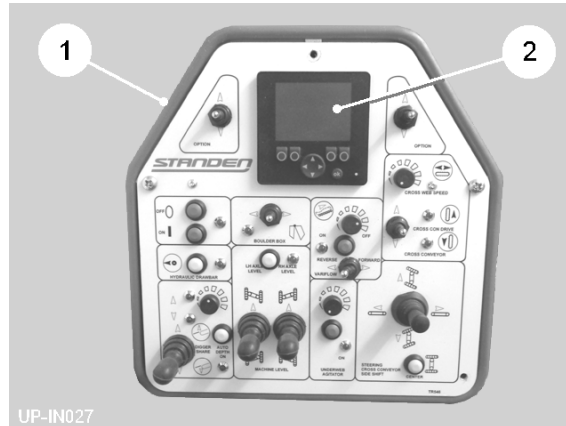

Fig 15

Ensure that all plug and socket connections are clean and coupling pins undamaged before connection, and that they are securely locked together before the power is switched on. The function of each control box switch is explained below.



Do not leave or store the control box outside in the open and always disconnect the control box from the tractor electrical supply when not in use, so avoiding the possibility of draining the battery.

Digger Share Raise / Lower :

The switch marked 'DIGGER SHARE' manually raises / lowers the digger assembly increasing / decreasing the depth of the shares below the soil. Releasing the switch to the central position leaves the share depth at the present setting. Setting the switch to the locked lower position enables the depth rams to free float.

Digger Share Auto-Depth :

With the digger share switch set in the lower position, the button activates / deactivates the digger share auto-depth system. The LED is illuminated when the system is ON. The share depth is automatically adjusted by the movement of the diablo roller. Operating the manual digger share raise/lower switch will override the auto-depth system. The auto-depth indicator lights show when the depth control sensors are operating. In work the digging depth can be varied using the digger share dial. Turn the dial clockwise to increase the share depth and anticlockwise to decrease the depth.

Axle Steer :

The switch marked 'AXLE STEER' manually steers the machine wheels to left / right. The 'CENTRE' button operates the self-centring circuit to automatically set the wheels to the straight-ahead position.

Machine Level :

The switches marked 'MACHINE LEVEL' operate the LH and RH levelling rams (item 1, fig 4).

Cross Conveyor :

The LH side of the cross conveyor is folded vertically to reduce the width for transport. Raising / lowering of the conveyor is controlled by the two external switches (item 1 & 2, fig 16) on the LH side of the machine.



Before raising / lowering the conveyor, always disengage PTO, set tractor gearbox to 'neutral' (or park lock), apply handbrake and set engine speed to idle. Ensure everyone in the vicinity is aware of your intentions.

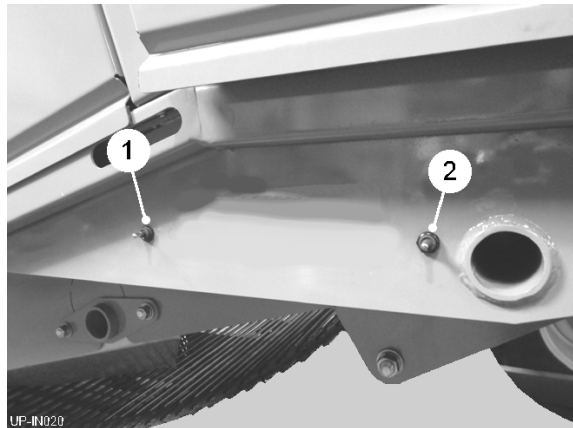

Fig 16

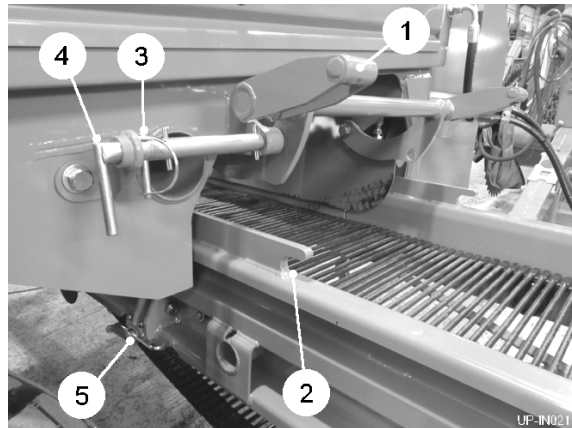

Fig 17

To unfold the cross conveyor:

1. Using the two external switches on the LH side of the machine, carefully lower the cross conveyor. Both switches need to be actuated and held to operate.
2. Once horizontal, disengage the latch arm (item 1, fig 17) from the hook plate (item 2, fig 17).
3. Raise the latch arm (item 1, fig 17) clear of the conveyor as shown.
4. Remove the linchpin (item 3, fig 17) and slide the support pin (item 4, fig 17) into the hole in the latch arm. Refit the linchpin.
5. Finally, lock the conveyor with the bottom catches (item 5, fig 17).

To fold the cross conveyor:

1. Unlock the conveyor bottom catches (item 5, fig 17).
2. Remove the linchpin (item 3, fig 17) and slide the support pin (item 4, fig 17) out to release the latch arm (item 1, fig 17). Refit the linchpin.



Always refit the linchpin to hold the support pin (item 4, fig 15) away from the latch arm (item 1, fig 15). Failure to do this could result in serious damage to the conveyor when folding.

3. Lower the latch arm (item 1, fig 17) onto the conveyor.
4. Using the two external switches, move the cross conveyor to engage the latch arm (item 1, fig 17) into the hook plate (item 2, fig 17).
5. Finally, carefully raise the conveyor until in full contact with the rubber stop (item 6, fig 17).

The switch marked 'CROSS CON DRIVE' starts / stops the cross conveyor web. With the switch in the centre position the discharge web is stopped. Move the switch up to discharge to the RH side of the machine, or down to discharge to the LH side. The corresponding LED will illuminate. The dial marked 'CROSS WEB SPEED' sets the speed of the discharge web.

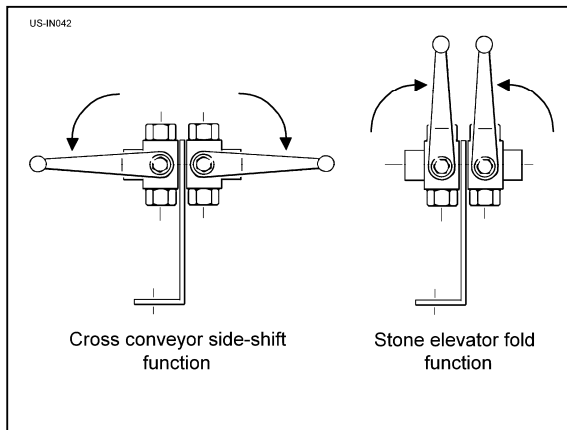

Fig 18

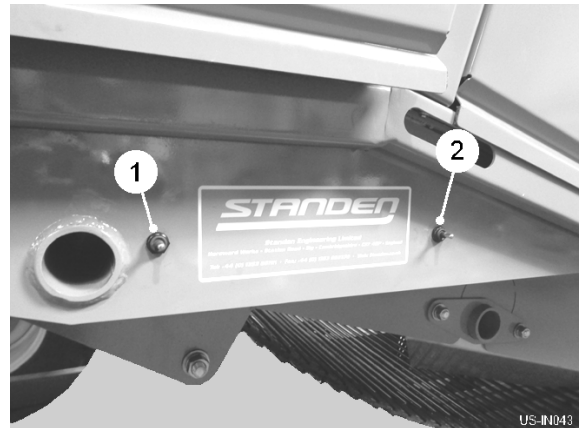

Fig 19

Stone Elevator:

The stone elevator function is selected by resetting the two manual valves (see fig 18) behind the 3rd LH guard door. Raising / lowering of the conveyor is controlled by the two external switches (item 1 & 2, fig 19) on the RH side of the machine.

To unfold the stone elevator, set the valve handles as shown (see fig 18).



Always ensure the cross conveyor is moved fully to the left before lowering the stone elevator. Ensure everyone in the vicinity is aware of your intentions.

Reset the valve handles to 'cross conveyor function' (see fig 18). Using the switches (item 1 & 2, fig 19), carefully move the cross conveyor sideways to close the gap between the conveyor and the stone elevator flights. Ensure the flights do not come into contact with the cross conveyor web when running.

Finally, reset the valve handles to 'stone elevator function' (see fig 18) to prevent inadvertently side-shifting the cross conveyor into the elevator during work.

Stone Elevator Drives:

Connect the stone elevator motor hydraulic hoses to the cross conveyor motor quick couplers. The stone elevator and cross conveyor hydraulic drives are linked. Therefore, the switch marked 'CROSS CON DRIVE' also starts / stops the stone elevator and the discharge speed is controlled by the dial marked 'CROSS WEB SPEED'.



Always disconnect the hydraulic hoses before folding the stone elevator.

Boulder Box (optional) :

The switch marked 'BOULDER BOX' opens / closes the boulder box for emptying. To empty the boulder box move the switch to the right. The LED will illuminate when the boulder box is open.

Vari-Flow (optional) :

The button starts / stops the Vari-Flow web. The LED is illuminated when the system is ON. Web speed is set on the dial. The web can be reversed using the switch marked 'FORWARD / REVERSE'.

Draper Web :

The switch marked 'draper web' lifts or lowers the draper web thus increasing/decreasing the pressure over the 4th web.

Hydraulic Drawbar (optional) :

The button marked 'HYDRAULIC DRAWBAR' activates / deactivates the hydraulically damped drawbar system. The LED is illuminated when the system is ON.

Lubrication

Regular lubrication is an integral part of looking after your machine. The schedule of maintenance outlined below is a guide to when certain actions should be carried out. If your machine requires a more frequent lubrication schedule because of your workload, then it is advisable to reduce the time intervals.

Shafts, bearings and pivot points fitted with grease nipples should be greased with good quality medium grease. Do not allow these points to run dry as this will accelerate wear.

When greasing bearings some are sealed and pre-lubricated. You should take care not to over grease this type as the seals may be damaged. If the seals become damaged it may be possible for dirt to enter the bearing causing accelerated wear.

The gearbox, mounted on the bridge in the centre of the machine, should be regularly examined for any signs of leaks. Fill with SAE 80W/90 GL5.

To ensure the efficient operation of the PTO shafts, it is vital to grease the sliding section on a daily basis. Failure to do this will result in early failure of the shafts. The PTO shaft should be disconnected from the tractor and the two halves pulled completely apart. Each half should be examined for any indication of tightness or binding when they are in operation and corrected as necessary. The inside of the outer tube and the outside of the inner tube should be liberally coated with grease and the two halves pushed back together. Wipe off any excess grease around the guards. Slide the two halves in and out several times to ensure that they slide easily and that the grease has spread around the shaft tubes.

Medium grease = BP Energrease L S E P 2

Gearbox oil = SAE 80W/90 GL5

Drive Belt Maintenance

The toothed drive belts have adjusters (item 1, fig 20) that are visible when the appropriate guard is opened. As a guide, correct belt tension is achieved when, at a distance half way between the furthest spaced pulleys, the belt can be twisted no more than 45° longitudinally. To set the boulder box belt tension (if fitted), firstly set the toothed belt tension by loosening the fixing bolts (item 1, fig 21) and adjusting the tensioner bolt (item 2, fig 21). Finally, adjust the 'V' belt tensioner (item 3, fig 21). Set the 'V' belts tight enough to give a positive drive without undue stretching.

Electrical System Maintenance

The components within the electrical system are designed to be maintenance free. If it becomes necessary to carry out any repair, only a competent engineer capable of this type of work should carry out the repair. Periodically ensure that all multi pin plugs are correctly fitted into their sockets and are not becoming loose.

Hydraulic System Maintenance

The components within the hydraulic circuit are designed, on the whole, to be maintenance free. If it becomes necessary to carry out any repair, the work should be carried out by a competent engineer capable of this type of work.



WARNING: Do not carry out any maintenance or release any hoses without first carrying out the residual hydraulic pressure dump procedure outlined later in this section.

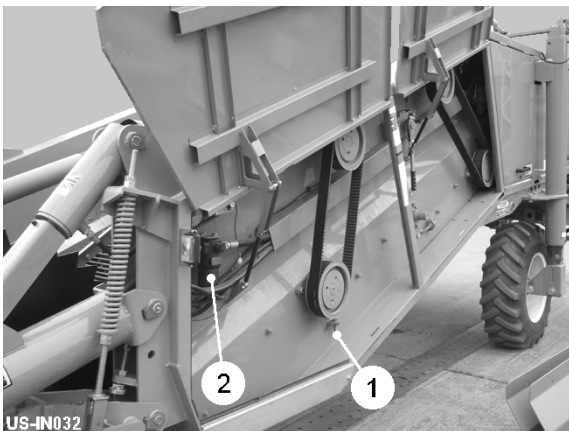

Fig 20

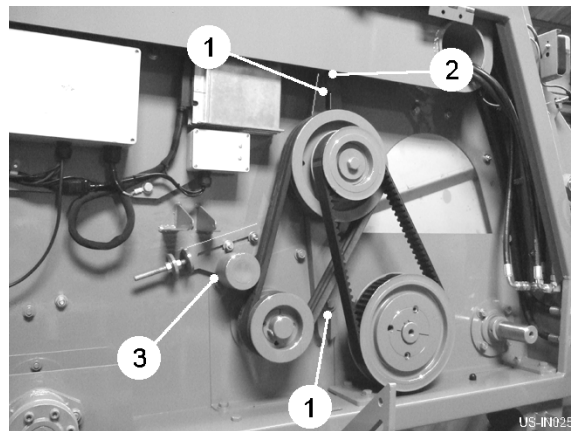

Fig 21

Cleanliness is of paramount importance. Before dismantling any part of the hydraulic system, ensure the surrounding area is clean. If necessary, power wash the area to be worked on. Dirt must be prevented from entering the system, so any orifices left open, such as pipe ends or ports of motors must be blanked off with a suitable plug. Do not use cloth or rag, as the lint from these can contaminate.

As the tractor supplies the oil for the machine's hydraulics, ensure that the tractor hydraulic system is serviced in accordance with the manufacturer's recommendations to prevent any contamination of the machine's system. To extend the life of the hydraulic components it is important to monitor the condition of the hydraulic oil. Always maintain adequate oil level in the tractor's reservoir.

A pressure filter (item 2, fig 20) is mounted in the supply line from the tractor. The element should be replaced after the first 50 hours of running time and then annually or every 500 hours thereafter.

Residual Hydraulic Pressure Dump Procedure

The following procedure outlines the method of relieving the residual pressure within the hydraulic system. It is essential that this procedure is carried out before any maintenance or repairs are attempted on the hydraulic system.

1. Place chocks to the front and rear of both wheels to prevent the machine from moving.
2. Lower the depth rams so that the drawbar is on its stand and disconnect the machine from the tractor, leaving the hydraulic and electrical connection still attached.
3. Move the tractor forward so that the machine drawbar is just clear of the tractor hook.
4. Operate the machine levelling rams until the machine is in its lowest position.
5. Switch off the tractor engine.
6. Operate all switches on the driver's control box, in turn, to remove any remaining pressure within the hydraulic system.
7. Disconnect the hydraulic and electrical connections from the tractor.

Split Web Drive Sprockets

Split web drive sprockets (item 1, fig 22) are used which allow worn sprockets to be replaced, or alternative pitch sprockets to be fitted without having to dismantle the drive shaft. Most drive sprockets will have been split on initial installation. If not, they should be split with a hammer and sharp chisel. Before splitting a sprocket on or off the machine, remove the four fixing bolts (item 2, fig 22). Keep the split halves in the correct pairs to prevent mismatch when refitting.

Note: When changing web sprockets, ensure that the new centre sprocket is fitted so that the web centre band will be offset from the adjacent web. This will prevent soil being carried from one centre band to the next.

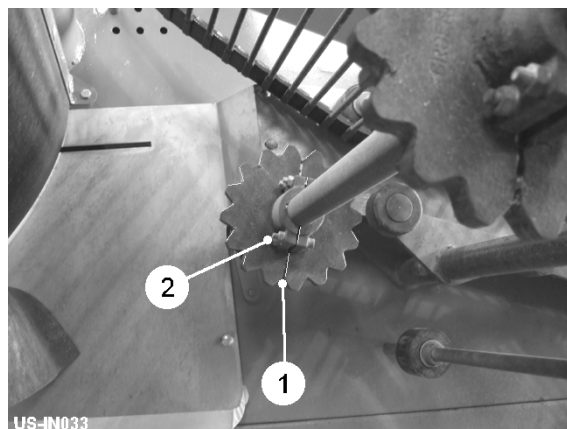

Fig 22

Daily Maintenance

During the working season the following daily maintenance should be carried out. Check all covers and guards are in position, free from damage, and all retaining latches and hinges are in place and operative. Repair or replace any found to be defective before operating the machine.

Carry out the following checklist: -

1. Check tension of all drive belts and adjust if necessary.
2. Check tyre pressures and adjust if necessary.
3. Check for any damaged or broken rollers, web bars or stars etc. Repair or replace as necessary.
4. Check wheel nuts for tightness.
5. Check all scraper clearances and adjust as necessary. Scrapers should be adjusted as close as possible without actually touching.
6. Check all hydraulic cylinders, valves and pipe work for signs of leaks or damage, repair or replace as necessary.
7. Carry out lubrication
8. Grease axle king pins

Weekly Maintenance

During the working season the following weekly maintenance should be carried out.

1. Carry out all the procedures listed in daily maintenance.
2. Check all shafts, bearings and rollers for undue wear, and replace as necessary.
3. Check all bearings for lubrication, grease as necessary.
4. Check discs and shares blades for excessive wear, replace if necessary.
5. Check hydraulic and gearbox oil levels.

Annual Maintenance

Prior to the start of the working season the following maintenance should be carried out.

1. Carry out all the procedures listed in daily and weekly maintenance.

2. Check cross conveyor web for any damage or wear and repair or replace as necessary.
3. Check stars and replace any badly worn or damage parts.
4. Check metalwork (e.g. side plates) for any damage or wear and repair or replace as necessary.
5. Inspect wheel bearings and check for excessive wear, replace as necessary. Re-pack with fresh grease on re-assembly.
6. Replace pressure filter element. Use only genuine Standen replacement parts.
THIS IS NOT A WASHABLE ELEMENT.
7. If a high water content becomes apparent or a cloudiness in the hydraulic oil, the oil should be changed.

Out of Season Storage

The machine can frequently operate in soils which contain chemical fertilisers etc. When the working season is completed wash and clean the machine thoroughly prior to carrying out the following checks and operations.

1. Apply oil, grease or an anti rust agent on any exposed bright metal surfaces which have been polished by the soil flow.
2. Clean all drive belts.
3. After carrying out the hydraulic residual pressure dump procedure, any parts of hydraulic cylinders rods that are still exposed should be greased or oiled to prevent corrosion.
4. Ensure that the tyres are inflated to the correct pressure.
5. Ensure that the hydraulic hose quick release couplings and the electrical connectors on the machine are kept clean and dry.
6. Check the whole machine carefully and note any repairs that may need to be carried out. It is always better to carry out any repairs well before the commencement of the following season.
7. Carry out all the lubrication checks outlined in routine maintenance.
8. Ensure the driver's control box is kept in a safe, dry place and available for use at the commencement of work or for any maintenance to be carried out.
9. Ensure that this handbook is kept in a safe place and available for use at the commencement of work or for any maintenance to be carried out.

Machine Dimensions

Length	8.50 m (including drawbar)
Length with boulder box	9.00 m (including drawbar)
Working width	4.05 m (maximum)
Transport width	2.85 m
Transport Height	2.60 m

Machine Weight

Basic machine	5180 kg
---------------	---------

Technical Data

Bed widths	1.7 to 2.0 m
Tractor power requirement	110 bhp minimum
Oil flow requirement from tractor (Set to constant pump)	minimum 70 ltr/min maximum 100 ltr/min
(For flows greater than 100 ltr/min consult your Standen dealer)	
Electrical requirements from tractor	12V DC negative earth
Drive requirement from tractor PTO	1 3/8" 6 spline @ 540 rpm maximum
Tyre size (standard)	14.5 x 20 MPT 10 Ply
Tyre pressure	3.5 Bar (51 psi)
Wheel nut torque (M20 x 1.5)	360 nm

Nut / bolt torque

Description	Torque	Description	Torque
M6 nyloc zinc nut	14 nm	M6 bolt/steel nut	10 nm
M8 nyloc zinc nut	31 nm	M8 bolt/steel nut	26 nm
M10 nyloc zinc nut	60 nm	M10 bolt/steel nut	52 nm
M12 nyloc zinc nut	118 nm	M12 bolt/steel nut	95 nm
M16 nyloc zinc nut	282 nm	M16 bolt/steel nut	230 nm
M20 nyloc zinc nut	515 nm	M20 bolt/steel nut	440 nm
M24 nyloc zinc nut	936 nm	M24 bolt/steel nut	766 nm

Wheel Track Settings Diagram

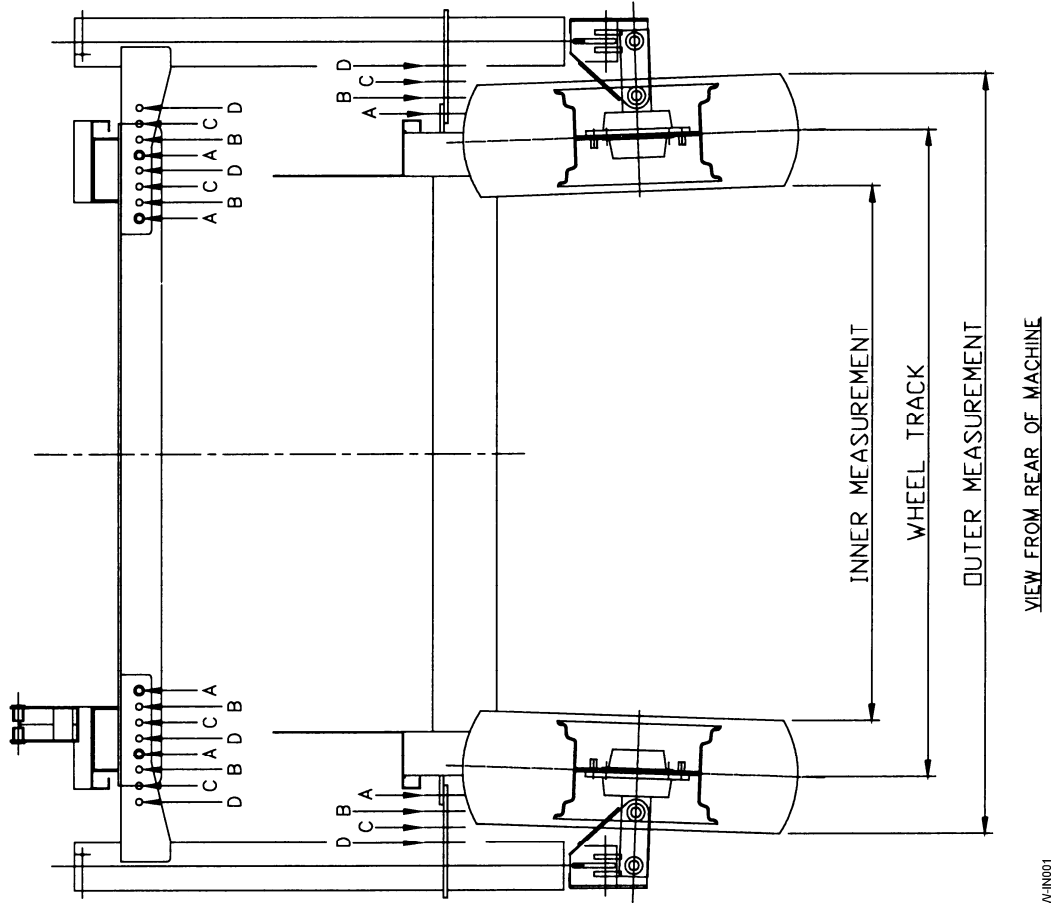

WHEEL SETTINGS 1500 & 1600mm MACHINE

LETTER	WHEEL TRACK	INNER MEASUREMENT	OUTER MEASUREMENT
A	80" (2.03M)	65.5" (1.66M)	94.5" (2.40M)
B	76" (1.93M)	61.5" (1.56M)	90.5" (2.30M)
C	72" (1.83M)	57.5" (1.46M)	86.5" (2.20M)
D	68" (1.73M)	53.5" (1.36M)	82.5" (2.10M)

WHEEL SETTINGS 1700mm MACHINE

LETTER	WHEEL TRACK	INNER MEASUREMENT	OUTER MEASUREMENT
A	84" (2.13M)	69.5" (1.76M)	98.5" (2.50M)
B	80" (2.03M)	65.5" (1.66M)	94.5" (2.40M)
C	76" (1.93M)	61.5" (1.56M)	90.5" (2.30M)
D	72" (1.83M)	57.5" (1.46M)	86.5" (2.20M)

ALL DIMENSIONS CAN BE REDUCED BY 2"(.05M) BY FITTING TWO ALTERNATIVE STUB AXLES (Part No 57495 - 2 off)

ALL DIMENSIONS CAN BE REDUCED BY 2.55"(.065M) BY FITTING TWO ALTERNATIVE STUB AXLES (Part No 57868 - 2 off)

1.29

Hydraulic Circuit

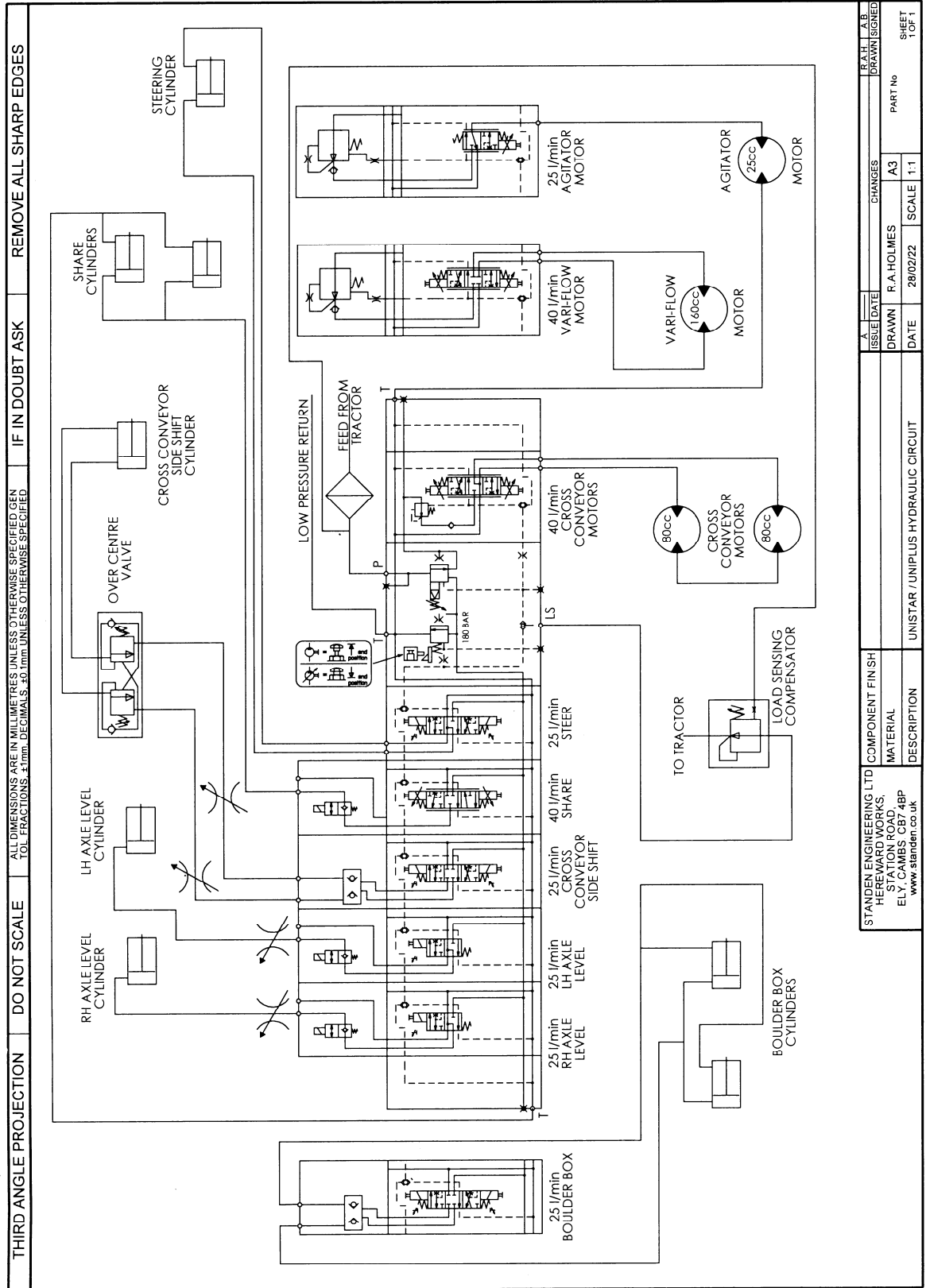

ELMR190 Output Information

ELMR190 PIN & CABLE NO	CABLE LENGTH	CABLE COLOUR	FUNCTION	OUTPUT CHANNEL	SENSOR INPUT	ESMR193 PIN
1	1200mm	BLUE	FUSED EARTH 0V			
2	2800mm	BLACK	LEFT AXLE LOWER	CH 10		X30.31
3	2800mm	BLACK	BOULDER BOX LOWER	CH 12		X40.3
4						
5						
6	1200mm	PURPLE	DIGGER DEPTH SENSOR		AIN 1	X30.28
7	1200mm	PURPLE	STEER SENSOR		AIN 3	X30.6
8						
9						
10	2800mm	BLACK	RIGHT AXLE RAISE	CH 24		X30.8
11	1200mm	ORANGE	SPARE TO DISTRIBUTION BOX	CH 20		X30.12
12						
13						
14						
15	1200mm	PURPLE	BOULDER BOX LED		DIN 8	X30.23
16						
17						
18						
19						
20	2800mm	RED	CROSS WEB RUN RIGHT	CH 14		X30.13
21				CH 16		
22	2800mm	RED	BOULDER BOX RAISE	CH 18		X40.27
23	1200mm	BROWN	REFERANCE VOLTAGE 8.5V			
24	2800mm	BLACK	DIGGER CHECK	CH 9		
25	2800mm	BLACK	RIGHT AXLE LOWER	CH 11		X30.32
26	1200mm	BLUE	CAN-LOW X 2			
27	1200mm	RED	CAN-HIGH X 2			
28	1200mm	BROWN	12 VOLT FEED			
29						
30						
31						
32						
33						
34	1200mm	PURPLE	HYDRAULIC DRAW BAR SENSOR		DIN 1	X30.2
35						
36						
37						
38						
39						
40						
41						
42	2800mm	RED	CROSS WEB RUN LEFT	CH 13		X30.37
43	1200mm	RED	VARIFLOW TO DISTRIBUTION BOX RELAY	CH 15		X30.38
44	2800mm	RED	AGITATOR	CH 17		X40.2
45	1200mm	ORANGE	SPARE TO DISTRIBUTION BOX	CH 19		X30.36
46	1200mm	BLACK	SPARE TO DISTRIBUTION BOX	CH 1		X30.1
47	1200mm	BLACK	SPARE TO DISTRIBUTION BOX	CH 2		X30.26
48	2800mm	RED	DIGGER RAISE	CH 3		X30.27
49	2800mm	RED	DIGGER LOWER	CH 4		X30.3
50	1200mm	BLACK	DRAPER WEB TO DISTRIBUTION BOX	CH 21		X40.1
51	1200mm	BLACK	DRAPER WEB TO DISTRIBUTION BOX	CH 22		X40.26
52	2800mm	BLACK	LEFT AXLE RAISE	CH 23		X30.7
53						
54	1200mm	BROWN	12 VOLT FEED			
55	1200mm	BLUE	EARTH 0V			
56	1200mm	BROWN	12 VOLT FEED			
57	1200mm	BROWN	12 VOLT FEED			
58	1200mm	BROWN	12 VOLT FEED			
59	1200mm	BROWN	12 VOLT FEED			
60	1200mm	BROWN	12 VOLT FEED			
61	2800mm	BLACK	AXLE STEER RIGHT	CH 6		X30.29
62	2800mm 1500mm	BLACK YELLOW	CROSS WEB SHIFT LEFT also yellow @ 1500mm for side s/witch	CH 7		X30.34
63	2800mm 1500mm	BLACK YELLOW	CROSS WEB SHIFT RIGHT also yellow @ 1500mm for side s/witch	CH 8		X30.11
64	2800mm	BLACK	AXLE STEER LEFT	CH 5		X30.4
65	1200mm	BLUE	EARTH 0V			
66	1200mm	BLUE	EARTH 0V			
67	1200mm	BLUE	EARTH 0V			
68	1200mm	BLUE	EARTH 0V			

CAN-bus Distribution Board

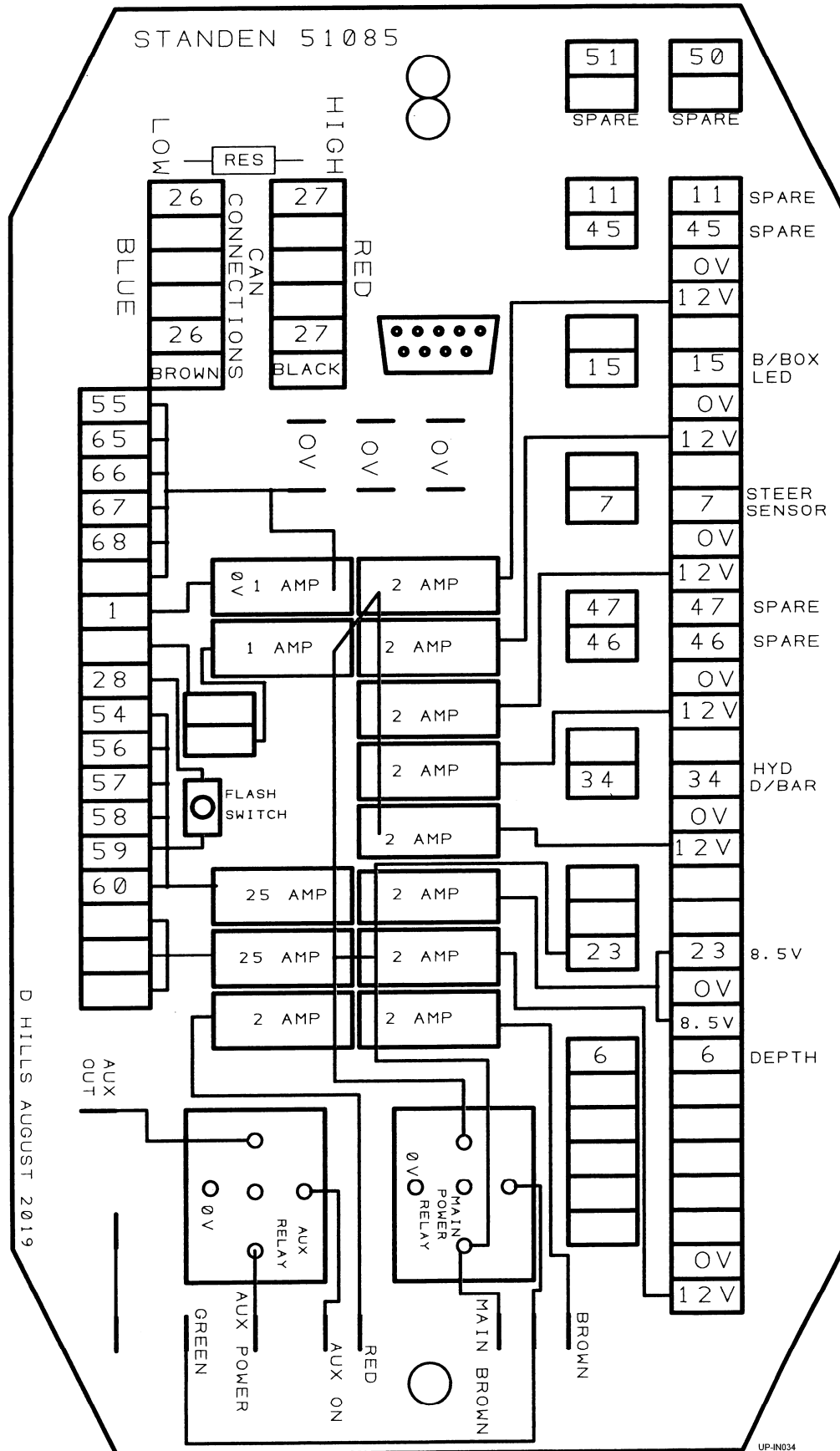

1.33 CIRCUIT DIAGRAMS

ESMR193 Connections

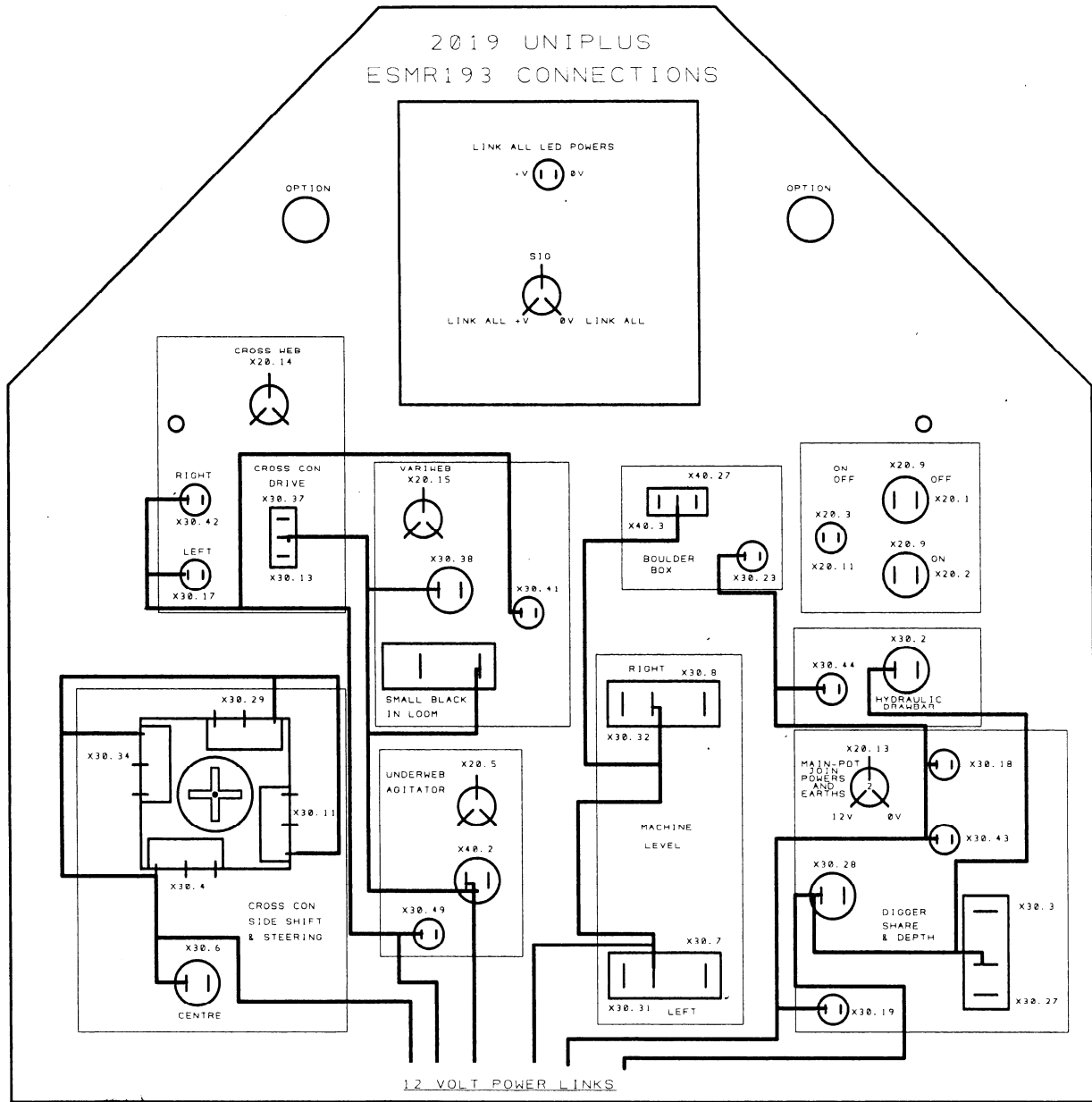

Cross Conveyor Relay & Sensor Information

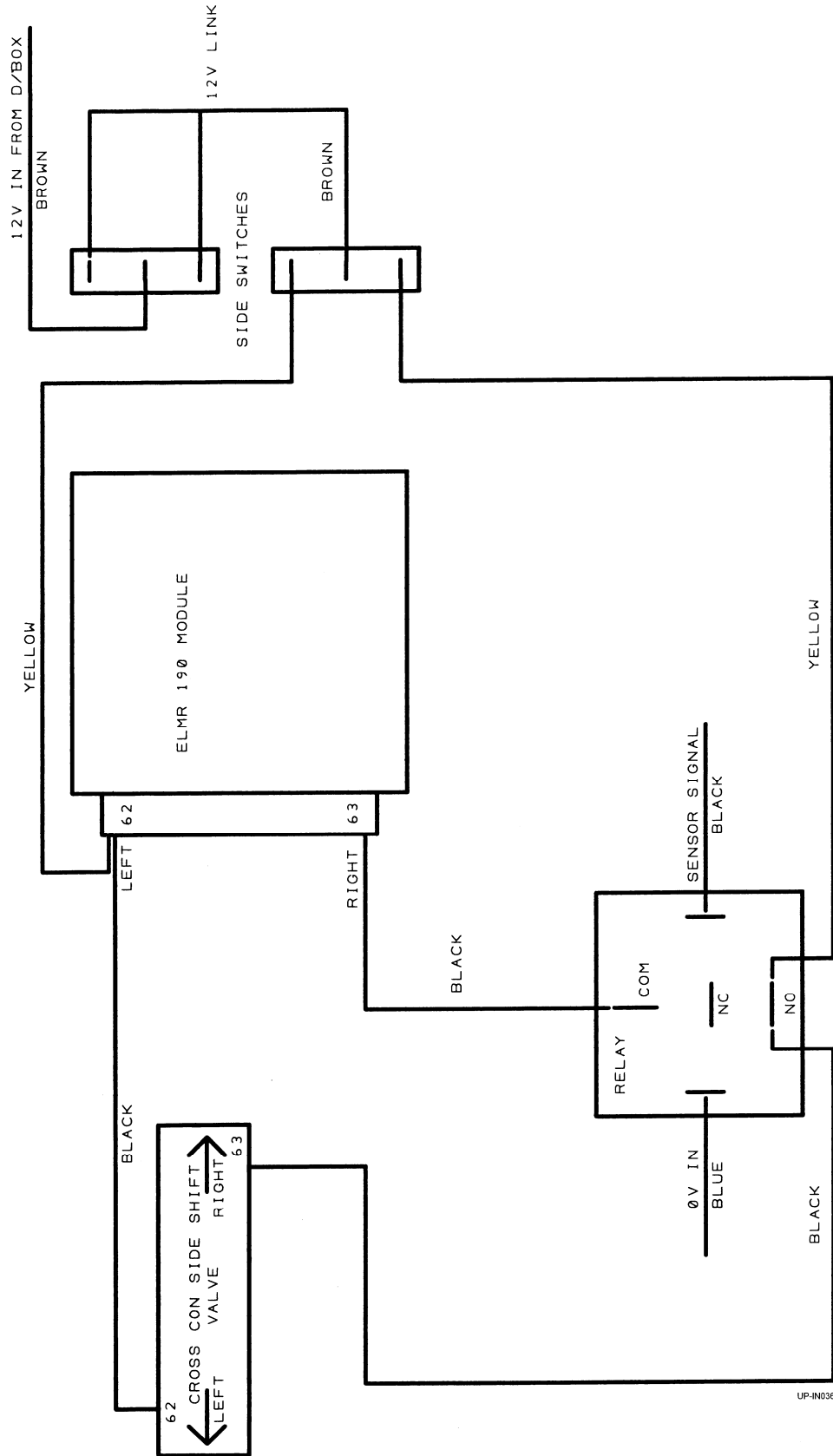

Automatic Stop Vari-Flow When Digger Is Lifted

