

# CONTENTS

## QUALITY MASTER SPARE PARTS

Drawbar & Main Frame	3.1
Axle & Wheels	3.2
Guards & Side Panels	3.3
Guards for Windrow Conveyor	3.5
Depth Wheels	4.1
LH & RH Disc Coulters	4.2
Share Assemblies for 2-Row Work	4.3
Share Assemblies for Bed Work	4.4
Anti Roll-back Flaps	4.5
Floating Chassis Assembly	4.6
Agitator Assembly	4.7
Main Web & Haulm Roller	4.8
Haulm Fingers	4.9
Centre Disc Coulters	4.10
5R Omega Separator (237mm centres)	5.1
Galaxy Star Separator	5.2
5R Omega Separator (220mm centres)	5.3
Star Spreader Assembly (for Omega)	6.1
Discharge Elevator (lower section)	6.2
Discharge Elevator (centre section)	6.3
Discharge Elevator (upper section)	6.4
Windrow Conveyor	6.5
Star Spreader Assembly (for galaxy)	6.6
PTO & Main Drives	7.1
Tractor Powered Hydraulics	7.2
Discharge Elevator Hydraulics	7.3
Omega Separator Hydraulics	7.5
Omega 2nd & 3rd Clod Roller Direction Control	7.6
Electrical Assembly	7.9
Road Lights	7.10
Clod Blocks Over Main Web	8.1
Web Cleaner	8.2
Haulm Skis	8.3
2nd Agitator	8.4
Fall Breaker Kit	8.5
Haulm Intake Rollers	8.6
Easi-pic Table (2 pickers)	8.7
Easi-pic Canopy (2 pickers)	8.8
Easi-pic Table (4 pickers)	8.9
Easi-pic Canopy (4 pickers)	8.10
Sweeping Clod Fingers	8.11
Galaxy Brush Kits	8.12
Braked Axle Assembly	8.13

**Note:** When using the following pages to order replacement parts, please quote the full serial number of your machine.



Machines from Serial No QM154

Drawbar & Main Frame

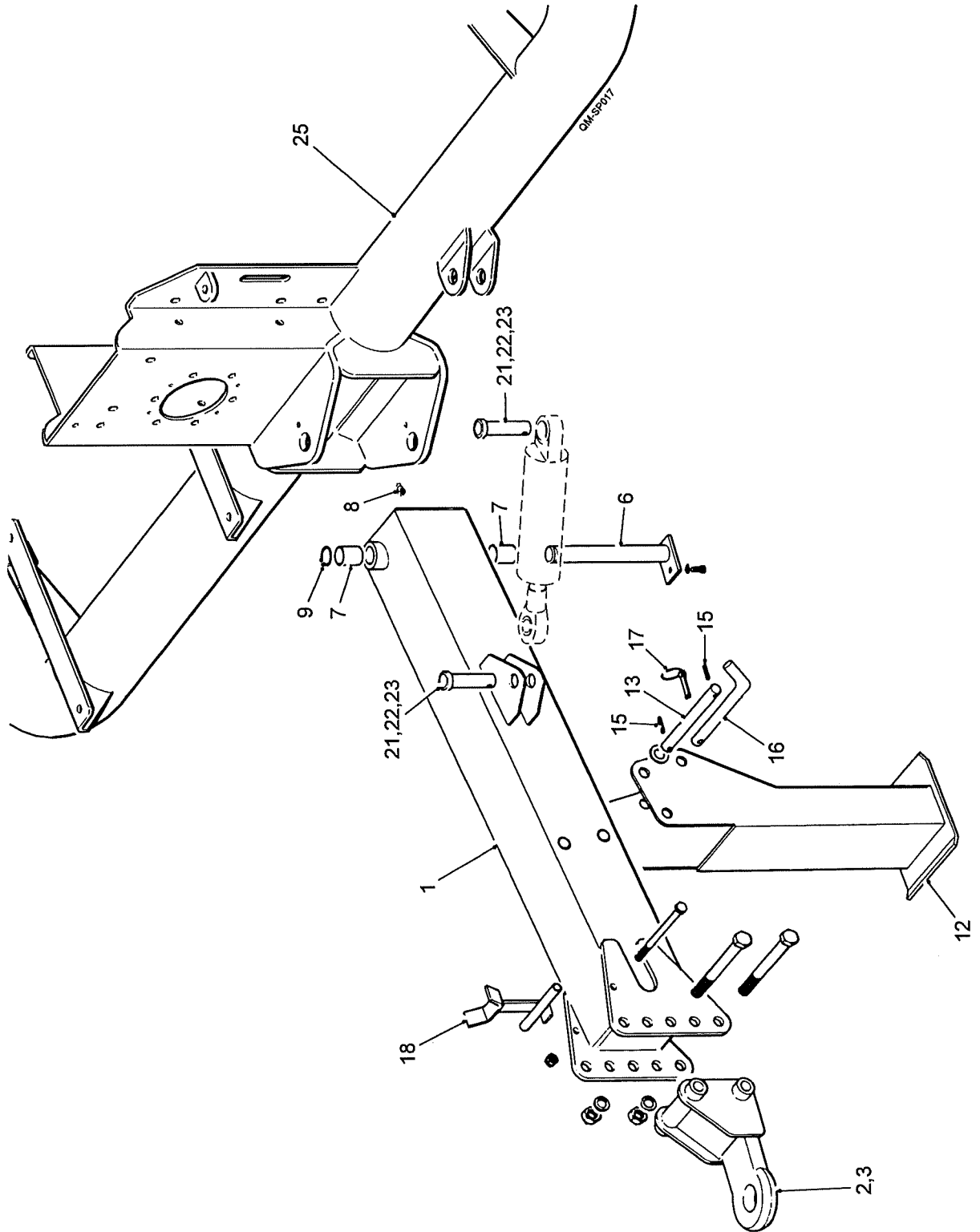

**3.1a****QUALITY MASTER SPARE PARTS**

Machines from Serial No QM154

**Drawbar & Main Frame**

Item	Part No.	Description	Qty.	Remarks
1	RPA610.307366	Drawbar	1	
2	RPA610.300014	Drawbar Eye	1	
3	RPM122.302709	Eye Reducer	1	Optional
4				
5				
6	RPA610.300036	Pivot Pin	1	
7	RPB250.303440	Pivot Bush	2	
8	RPC648.081250	M8 Straight Grease Nipple	1	
9	RPF200.030200	Ø30 External Circlip	1	
10				
11			1	
12	RPA610.307369	Drawbar Stand	1	
13	RPM146.307375	Pin	1	
14			2	
15	RPF220.060030	Ø6x30 Roll Pin	1	
16	RPM146.305150	Pin	1	
17	RPF232.060000	Linch Pin	1	
18	RPA610.307371	PTO Rest	1	
19				
20			2	
21	RPM146.300537	Ram Pin	2	
22	RPM176.300906	Spacer (9mm)	2	
23	RPF230.080000	Linch Pin	2	
24				
25	67003	Main Frame	1	

Machines from Serial No QM154

## Axle & Wheels

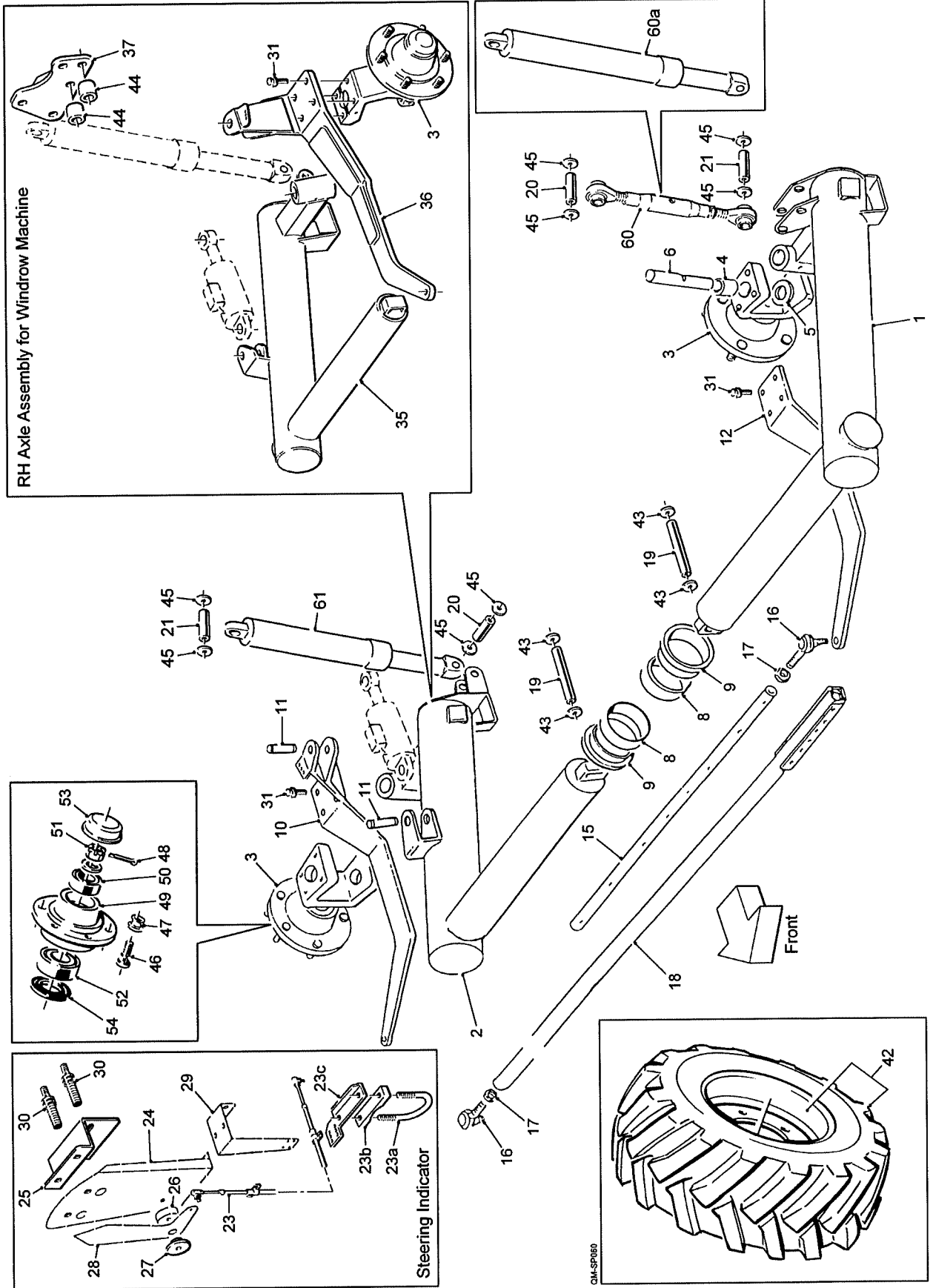

## 3.2a

## QUALITY MASTER SPARE PARTS

Machines from Serial No QM154

## Axle &amp; Wheels

Item	Part No.	Description	Qty.	Remarks
1	RPA610.305516	Axle LH	1	
2	RPA610.305515	Axle RH	1	Standard machine only
3	RPA610.306382	Axle Hub & Fork Assembly	2	(see list at end)
4	RPB250.404430	Bush	4	
5	RPGM065.00046	Thrust Washer	2	
6	RPM146.304860	King Pin	2	
7				
8	RPM162.305698	Bush Inner	2	
9	RPM162.305699	Bush Outer	2	
10	RPA610.305651	Steering Arm RH	1	Standard machine only
11	RPM146.306263	Ø25 Pin (90mm)	2	
x11	RPF200.025200	Ø25 External Circlip	4	
12	RPA610.310478	Steering Arm LH	1	
13				
14				
15	RPM162.300171	Track Rod Inner	1	
16	RPGMB89.02017	M20 Ball Joint	2	
17	RPF174.220000	M20 Locknut	2	
18	RPA610.300172	Track Rod Outer	1	
19	67376	Ø20 Pin (tapped)	2	Was RPM146.306264
20	67389	Ø25 Pin (tapped)	2	Was RPM146.306263
21	67389	Ø25 Pin (tapped)	2	Was RPM146.306265
22				
23	RPGMRP200.03046	Steering Indicator Cable	1	
23a	RPM186.302919	Stud U Clamp	1	
23b	RPC730.302920	Plastic Saddle	1	
23c	RPM226.300851	Steering Indicator Bracket	1	
24	RPM226.300853	Steering Indicator Plate	1	
25	58310	Guard	1	Was RPM225.305122
26	RPM148.305576	Pivot Bush	1	
27	RPM148.305577	Pivot Bush	1	
28	RPM226.300852	Steering Indicator Pointer	1	
29	RPM225.306761	Steering Indicator Mounting	1	
30	RPE282.303483X/1	Sensor	2	
31	RPF130.716040	M16x40 Locking Screw	8	
32				
33				
34				
35	67014	Axle RH	1	Windrow machine only
36	67015	Steering Arm RH	1	Windrow machine only
37	67044	Ram Mounting	1	Windrow machine only
38				
39				
40				
41				
42	RPW422.305966	12.5/80-18 Ply Wheel Assembly	2	Standard machine only
	RPW422.305966	12.5/80-18 Ply Wheel Assembly LH	1	Windrow machine only
	-	12.5/80-18 Ply Wheel Assembly RH	1	Windrow machine only

# QUALITY MASTER SPARE PARTS

3.2b

Machines from Serial No QM154

## Axle & Wheels

Item	Part No.	Description	Qty.	Remarks
43	SS038009/005	Steel Spacer	4	Windrow machine only
44	SS050026/060	Steel Spacer	2	
45	SS040011/005	Steel Spacer	8	
		<b>Axle Hub Consists Of:</b>		
46	13208	M18 Stud	6	
47	13209	M18 Nut	6	
48	23248	Split Pin	1	
49	23252C	Housing	1	
50	DW256512255	Outer Bearing	1	
51	RPF178.539000	M39 Nut	1	
52	RPB214.302100	Inner Bearing	1	
53	RPC620.303955	Hub Cap	1	
54	RPS206.652000	Seal	1	
		_____		
		<b>67218A</b>		
		<b>Standard RH Ram with LH Link Consists Of:</b>		
60	DW208007980	Top Link Complete	1	
61	RPH870.305700	Hydraulic Ram	1	
		_____		
		<b>67218B</b>		
		<b>Twin Rams for 150mm Extra Height at Rear Consists Of:</b>		
60a	67215	Hydraulic Ram LH	1	
61	67216	Hydraulic Ram RH	1	
		_____		
		<b>67218C</b>		
		<b>Twin Rams for Windrow Consists Of:</b>		
60a	67217	Hydraulic Ram LH	1	
61	67145	Hydraulic Ram RH	1	





Machines from Serial No QM154

Guards & Side Panels

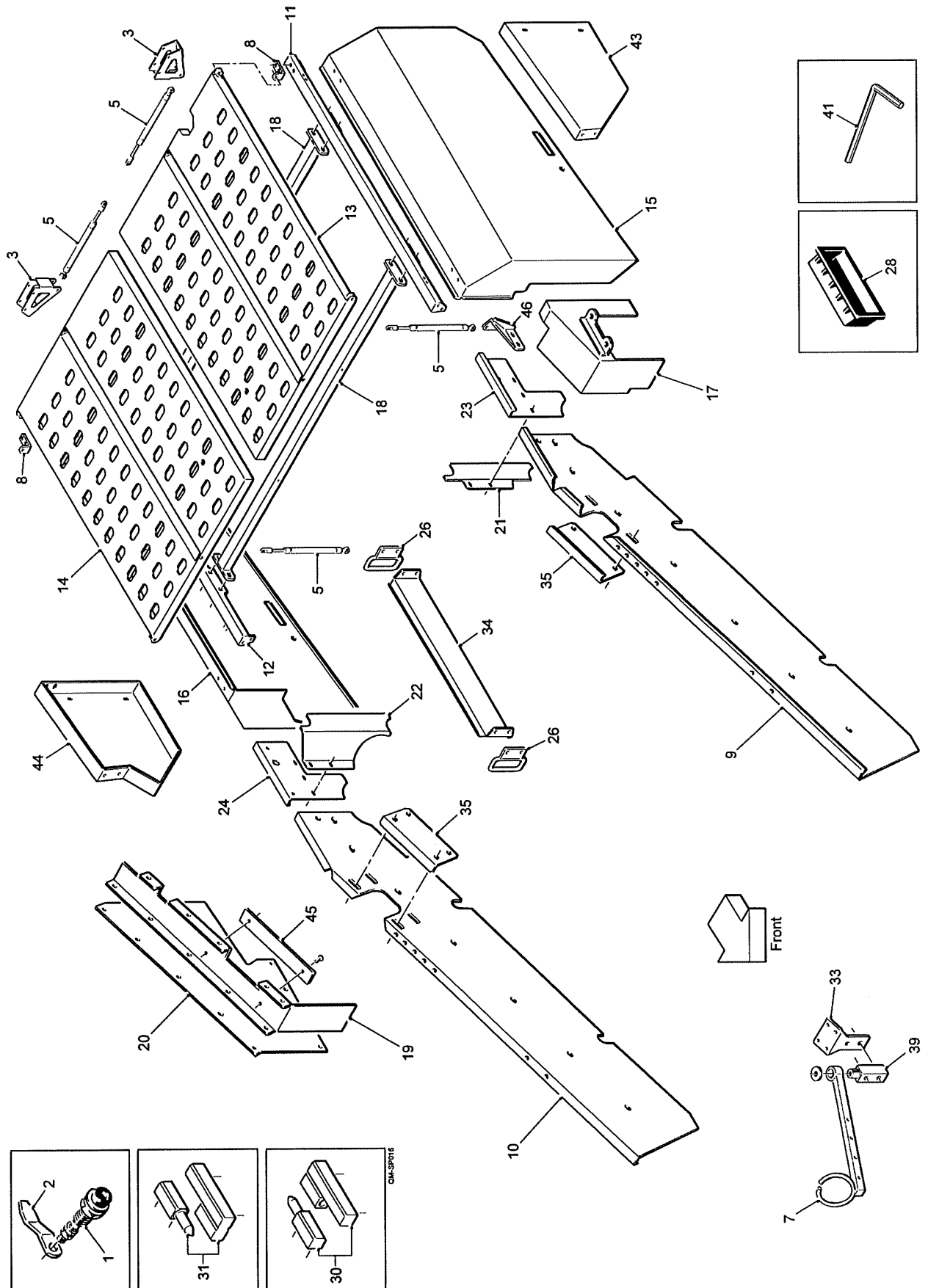

**3.3a****QUALITY MASTER SPARE PARTS**

Machines from Serial No QM154

**Guards & Side Panels**

Item	Part No.	Description	Qty.	Remarks
1	57199	Lock Assembly	4	
2	57219	Lock Arm	4	
3	57991	Gas Strut Bracket	2	
4				
5	58111	Gas Strut	4	
6				
7	59570	Hose Support Arm	1	
8	67214	Alignment Bracket	2	
9	67020	Main Stainless Panel LH	1	
10	67021	Main Stainless Panel RH	1	
11	67024	Guard Mounting Rail LH	1	
12	67025	Guard Mounting Rail RH	1	
13	67026	Top Guard LH	1	
14	67027	Top Guard RH	1	
15	67028	Guard Door LH	1	
16	67029	Guard Door RH	1	
17	67202	Drive Guard	1	Was 67030
18	67052	Top Guard Cross Beam	2	
19	67058	Agitator Top Guard	1	
20	67059	Agitator Side Guard	1	
21	67061	Deflector Panel LH	1	Omega only
22	67062	Deflector Panel RH	1	Omega only
23	67119	Separator Feed Panel LH	1	Omega only
24	67120	Separator Feed Panel RH	1	Omega only
25				
26	RPA610.306415	Hose Support	2	
27				
28	RPC658.300685	Door Pocket Pull	2	
29				
30	RPGMRPB99.03510	Hinge Complete	2	
31	RPGMRPB99.03511	Hinge Complete	2	
32				
33	RPM108.304208	Mounting Bracket	1	
34	RPM216.306884	Guard	1	
35	RPM224.307193S	Infill Panel	2	
36				
37				
38				
39	RPS230	Pivot Block	1	
40				
41	-	M8 Allen Key	1	
42				
43	67033	Wheel Infill Panel LH	1	
44	67034	Wheel Infill Panel RH	1	
45	67367	Chain Rubbing Strip	1	
46	67386	Gas Strut Bracket	1	Used from QM159

Machines from Serial No QM154

**Guards for Windrow Conveyor**

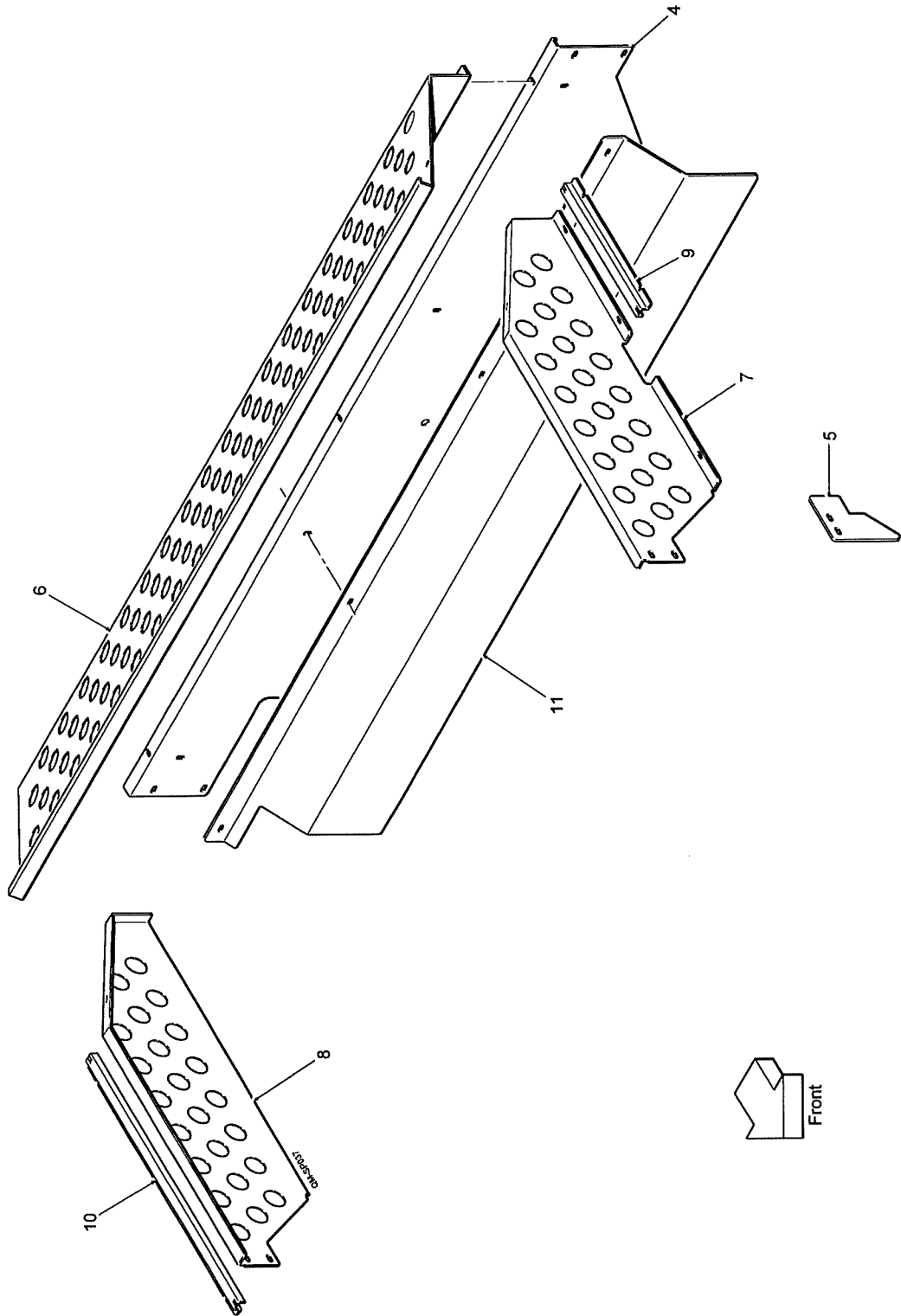

**3.5a****QUALITY MASTER SPARE PARTS**

Machines from Serial No QM154

**Guards for Windrow Conveyor**

Item	Part No.	Description	Qty.	Remarks
1				
2				
3				
4	67036	Rear Panel	1	
5	67038	Infill Plate	1	
6	67046	Rear Infill Panel	1	
7	67047	Infill Panel LH	1	
8	67048	Infill Panel RH	1	
9	67049	Cable Conduit LH	1	
10	67050	Cable Conduit RH	1	
11	67057	Rear Deflector Panel	1	

Machines from Serial No QM154

Depth Wheels

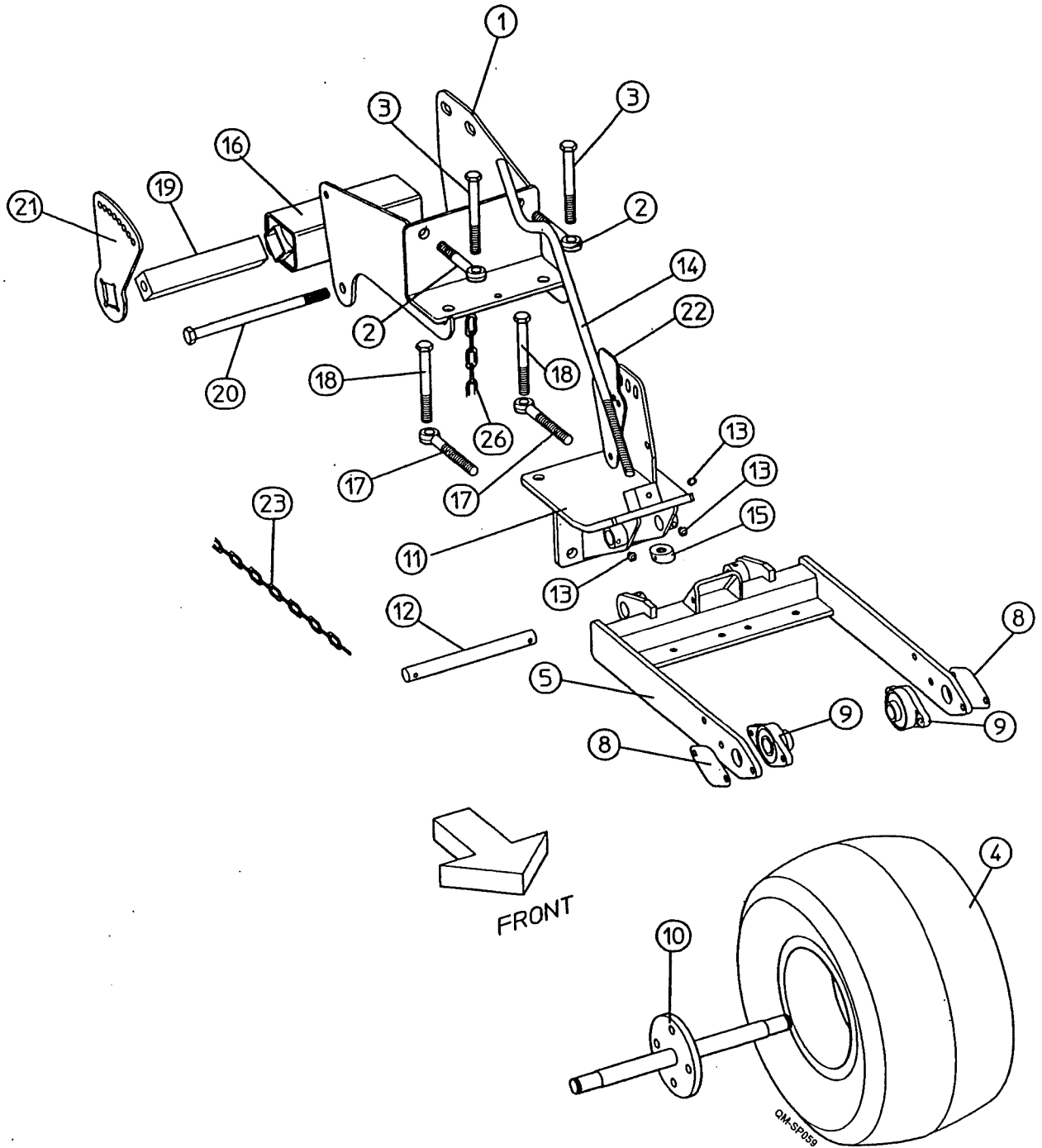

## 4.1a

## QUALITY MASTER SPARE PARTS

Machines from Serial No QM154

## Depth Wheels

Item	Part No.	Description	Qty.	Remarks
1	RPA610.306229	Mounting Bracket	2	
2	RPF120.116095	Eye Bolt	4	
3	RPF100.116150	M16x150 Hex Head Bolt	4	
4	RPRPB93.08125	Wheel Complete	2	
x4	RPF130.214045	M14x45 Hex Head Setscrew	8	
x4	RPC655.309696	M14 Wheel Nut	8	
5	RPS648	Depth Wheel Frame (300mm wide)	2	
	RPA610.309440	Depth Wheel Frame (360mm wide)	2	
6				
7				
8	RPM206.300116	Cover Plate	4	
9	RPB242.000252	Bearing	4	
x9	RPF200.025200	Ø25 External Circlip	4	
10	RPS649	Wheel Shaft	2	For 300mm wide frame
	RPA610.307206	Wheel Shaft	2	For 360mm wide frame
11	RPA610.306225	Mounting	2	
12	RPM146.301538	Pivot Pin	2	
x12	RPF220.080040	Ø8x40 Roll Pin	2	
13	RPC648.081252	Grease Nipple	6	
14	RPM217.306230	Adjusting Handle	2	
15	RPM106.301620	Boss	2	
x15	RPF220.060040	Ø6x40 Roll Pin	2	
16	RPRP084.00014	Torsion Unit	2	
17	RPF120.116115	Eye Bolt	4	
18	RPF100.116130	M16x130 Hex Head Bolt	4	
19	RPM166.300084	Suspension Unit Carrier	2	
20	RPF100.116260	M16x260 Hex Head Bolt	2	
21	RPM226.300156	Quadrant	2	
22	RPM226.300105	Target Plate	2	
23	RPC622.306061	Chain	2	

Machines from Serial No QM154

Disc Coulters

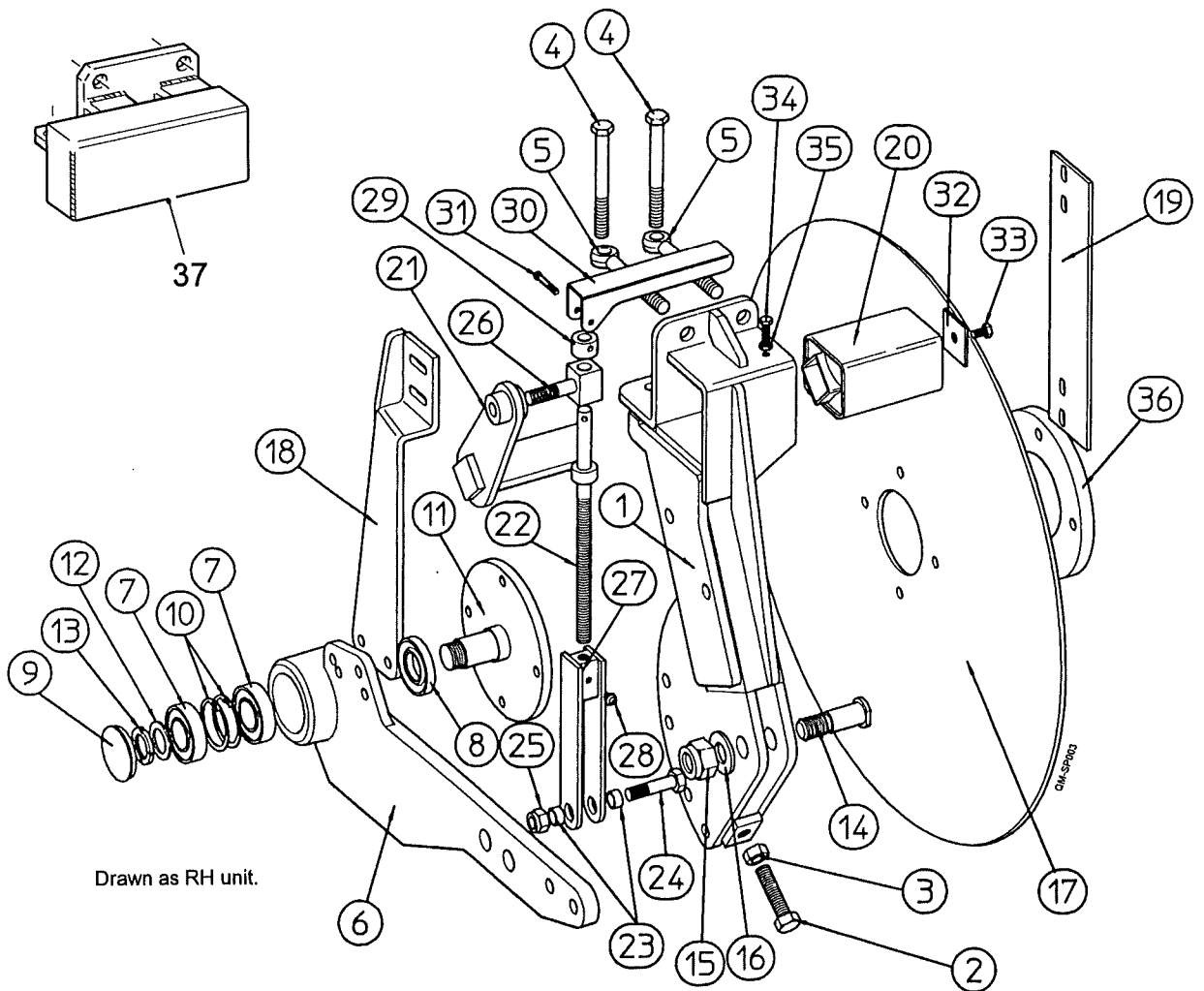

## 4.2a

## QUALITY MASTER SPARE PARTS

Machines from Serial No QM154

## Disc Coulters

Item	Part No.	Description	Qty.	Remarks
1	RPA610.301531	Disc Mounting RH	2	
x	RPA610.301530	Disc Mounting LH	2	
2	RPF130.116000	M16x120 Hex Head Setscrew	4	
3	RPF170.116000	M16 Full Nut	4	
4	RPF100.116150	M16x150 Hex Head Bolt	8	
5	RPF120.116095	Eye Bolt	8	
6	RPA610.301520	Bearing Arm RH	2	
x	RPA610.301519	Bearing Arm LH	2	
7	RPB200.060072	Bearing	8	
8	RPS200.406810	Oil Seal	4	
x	RPC648.081250	M8 Grease Nipple	4	
9	RPC700.300441	Plastic End Cap	4	
10	RPF202.062200	Ø62 Internal Circlip	8	
11	RPM180.300241	Disc Spindle	4	
12	RPF280.315640	M30 Flat Washer	4	
13	RPF180.230000	M30 Special Locknut	4	
14	RPM146.303752	Pivot Pin	4	
15	RPF176.124000	M24 Nyloc Nut	4	
16	RPF280.255040	M24 Flat Washer	4	
17	RPM120.300251	Disc	4	
	RPGMRP089.01829	Scalloped Disc	4	
x17	RPF132.112030	M12x30 Socket Head Screw	16	
18	RPA610.301535	Scraper Arm RH	2	
x	RPA610.301534	Scraper Arm LH	2	
19	RPW240.303093	Scraper	4	
x19	RPF102.110025	M10x25 Carriage Bolt	8	
20	RPRP084.00001	Torsion Unit	4	
21	RPA610.302189	Tension Arm RH	2	
x	RPA610.301509	Tension Arm LH	2	
22	RPA610.301512	Adjuster Rod	4	
23	RPM172.301506	Sleeve	8	
24	RPF100.116060	M16x60 Hex Head Bolt	4	
25	RPE176.116000	M16 Nyloc Nut	4	
26	RPM178.301500	Spigot	4	
27	RPA610.301513	Adjuster Block	4	
28	RPC648.081250	M8 Grease Nipple	4	
29	RPM114.301502	Collar	4	
30	RPM226.301510	Handle	4	
31	RPF100.106045	M6x45 Hex Head Bolt	4	
32	RPM152.303434	Retainer	4	
33	RPF130.110025	M10x25 Hex Head Setscrew	4	
34	RPF130.108020	M8x20 Hex Head Setscrew	4	
35	RPF170.108000	M8 Full Nut	4	
36	RPM152.308652	Retainer	4	
37	RPS311	Mounting Bracket RH	2	
x	RPS310	Mounting Bracket LH	2	



Machines from Serial No QM155

**LH & RH Disc Coulters**

Assy No RPS922 & RPS923

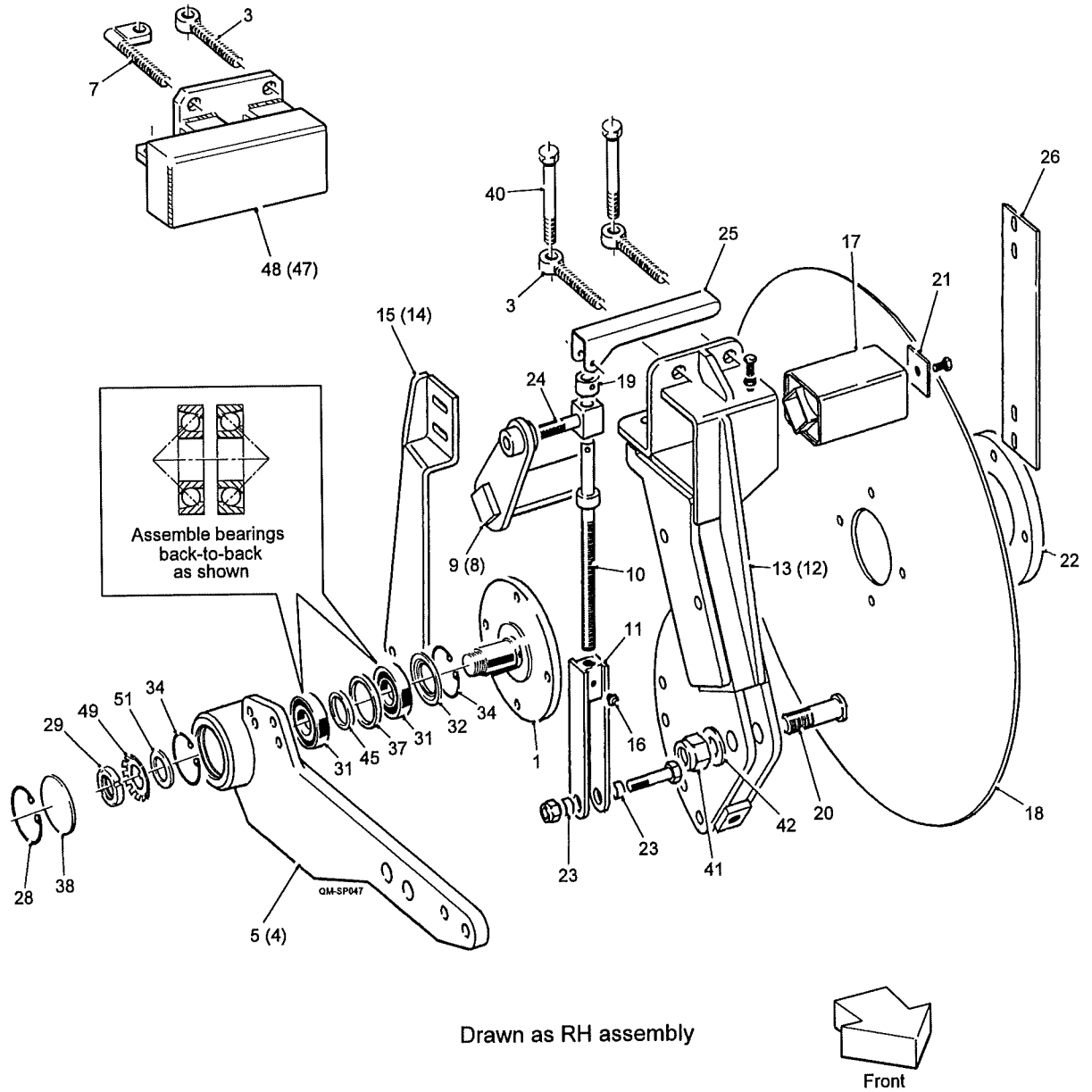

## 4.2a

## QUALITY MASTER SPARE PARTS

Machines from Serial No QM155

## LH &amp; RH Disc Coulters

Assy No RPS922 &amp; RPS923

Item	Part No.	Description	Qty.	Remarks
1	64977	Disc Spindle	1	
2				
3	RPF120.116095	M16x115 Eyebolt	3	
4	64975	LH Disc Arm (not shown)	1	
5	64976	RH Disc Arm	1	
6				
7	RPS1211	Cranked M16 Eye Bolt	1	
8	RPA610.301509	LH Disc Torsion Arm (not shown)	1	
9	RPA610.302189	RH Disc Torsion Arm	1	
10	RPA610.301512	Disc Adjuster Spindle	1	
11	RPA610.301513	Block Adjuster	1	
12	RPA610.301530	LH Disc Mounting Arm (not shown)	1	
13	RPA610.301531	RH Disc Mounting Arm	1	
14	RPA610.301534	Scraper Mounting LH (not shown)	1	
15	RPA610.301535	Scraper Mounting RH	1	
16	RPC648.081250	M8 Straight Grease Nipple	2	
17	RPGMRP084.00001	Rubber Torsion Unit	1	
18	RPM120.300251	Plain Disc (Ø740mm)	1	Option
	RPGM089.00018	Plain Disc (Ø645mm)	1	Option
	RPGMRP089.01829	Serrated Disc	1	Option
19	RPM114.301502	Collar	1	
20	RPM146.303752	Pivot Pin	1	
21	RPM152.303434	Retainer	1	
22	RPM152.308652	Retainer	1	
23	RPM172.301506	Sleeve	2	
24	RPM178.301500	Spigot	1	
25	RPM226.301510	Handle	1	
26	RPW240.303093	Disc Scraper	1	
27				
28	46564	Ø90 Internal Circlip	1	
29	45038	M40 Locknut	1	
30				
31	72092RS	Bearing	2	
32	6209ZJV	Nilos Ring	1	
33				
34	W0554	Ø85 Internal Circlip	2	
35				
36				
37	64189	Bearing Spacer Outer	1	
38	64190	Dust Cap	1	
39				
40	22012016/150	M16x150 Bolt	2	
41	22041024	M24 Nyloc Nut	1	
42	22046024C	M24 Flat Washer	1	
43				
44				
45	64978	Bearing Spacer Inner	1	
46				
47	RPS310	Mounting Bracket LH (not shown)	1	
48	RPS311	Mounting Bracket RH	1	
49	RPF284.140000	Lock Washer	1	
50				
51	SS060041/003	Steel Spacer	1	

Machines from Serial No QM158

**LH & RH Disc Coulters**  
Assy No RPS922 & RPS923

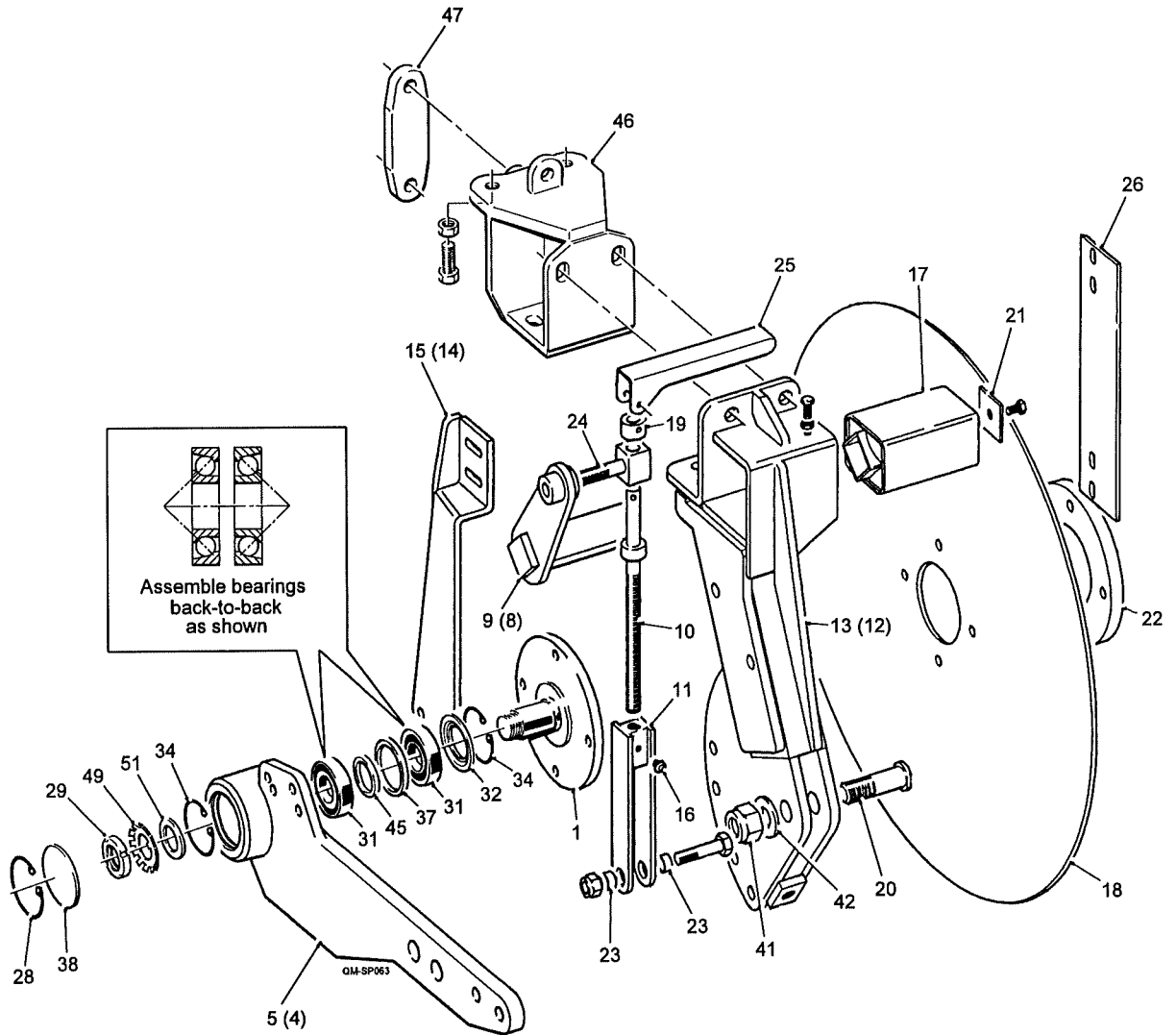

Drawn as RH assembly

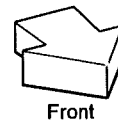

## 4.2a

## QUALITY MASTER SPARE PARTS

Machines from Serial No QM158

## LH &amp; RH Disc Coulters

Assy No RPS922 &amp; RPS923

Item	Part No.	Description	Qty.	Remarks
1	64977	Disc Spindle	1	
2				
3				
4	64975	LH Disc Arm (not shown)	1	
5	64976	RH Disc Arm	1	
6				
7				
8	RPA610.301509	LH Disc Torsion Arm (not shown)	1	
9	RPA610.302189	RH Disc Torsion Arm	1	
10	RPA610.301512	Disc Adjuster Spindle	1	
11	RPA610.301513	Block Adjuster	1	
12	RPA610.301530	LH Disc Mounting Arm (not shown)	1	
13	RPA610.301531	RH Disc Mounting Arm	1	
14	RPA610.301534	Scraper Mounting LH (not shown)	1	
15	RPA610.301535	Scraper Mounting RH	1	
16	RPC648.081250	M8 Straight Grease Nipple	2	
17	RPGMRP084.00001	Rubber Torsion Unit	1	
18	RPM120.300251	Plain Disc (Ø740mm)	1	Option
	RPGM089.00018	Plain Disc (Ø645mm)	1	Option
	RPGMRP089.01829	Serrated Disc	1	Option
19	RPM114.301502	Collar	1	
20	RPM146.303752	Pivot Pin	1	
21	RPM152.303434	Retainer	1	
22	RPM152.308652	Retainer	1	
23	RPM172.301506	Sleeve	2	
24	RPM178.301500	Spigot	1	
25	RPM226.301510	Handle	1	
26	RPW240.303093	Disc Scraper	1	
27				
28	46564	Ø90 Internal Circlip	1	
29	45038	M40 Locknut	1	
30				
31	72092RS	Bearing	2	
32	6209ZJV	Nilos Ring	1	
33				
34	W0554	Ø85 Internal Circlip	2	
35				
36				
37	64189	Bearing Spacer Outer	1	
38	64190	Dust Cap	1	
39				
40				
41	22041024	M24 Nyloc Nut	1	
42	22046024C	M24 Flat Washer	1	
43				
44				
45	64978	Bearing Spacer Inner	1	
46	67345	Mounting Bracket	2	
47	67346	Clamp Plate	2	
48				
49	RPF284.140000	Lock Washer	1	
50				
51	SS060041/003	Steel Spacer	1	

Machines from Serial No QM154

Shares Assemblies for 2-Row Work

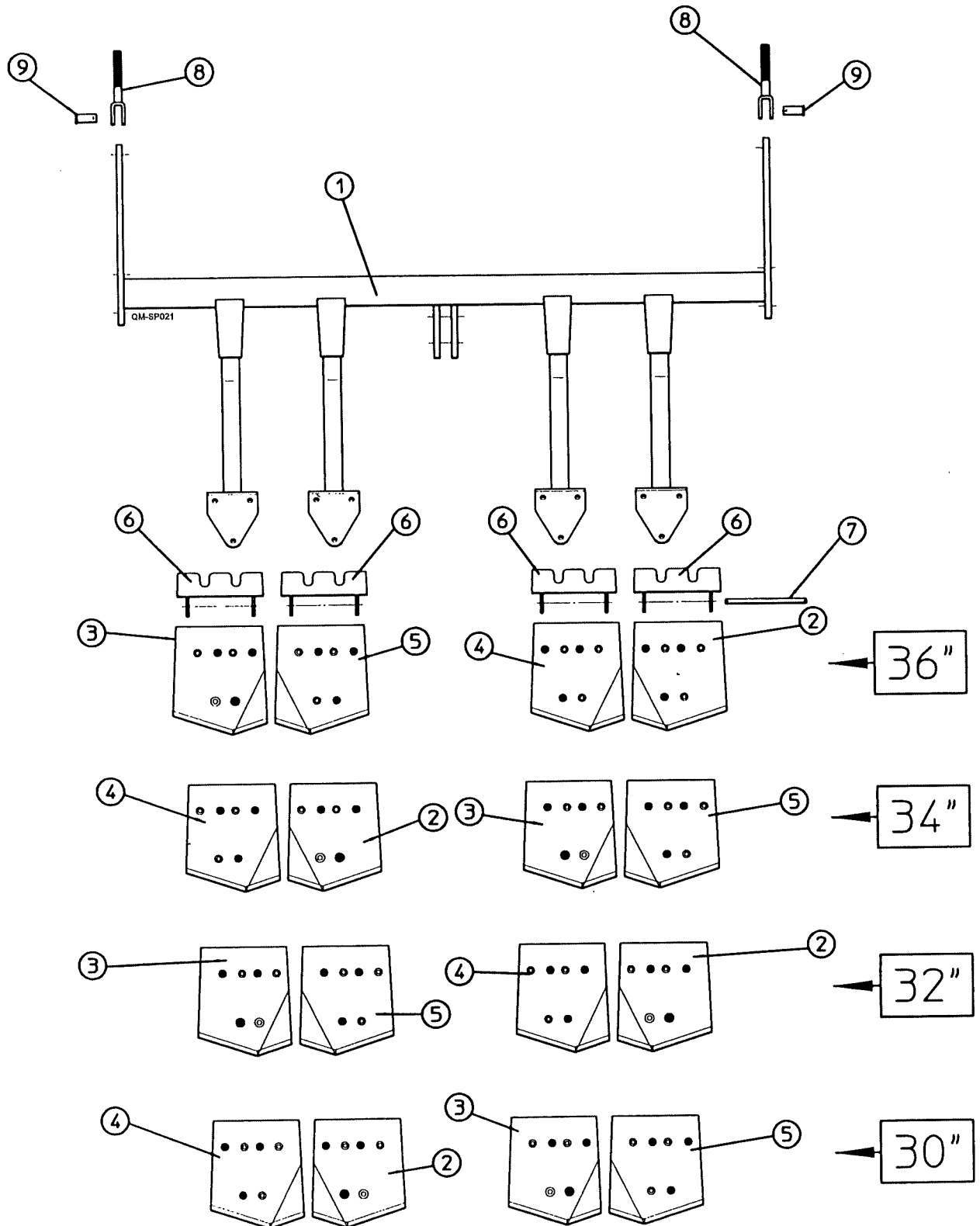

## 4.3a

## QUALITY MASTER SPARE PARTS

Machines from Serial No QM154

## Shares Assemblies for 2-Row Work

Item	Part No.	Description	Qty.	Remarks
1	RPA610.311065	Share Bar (1500mm)	1	
2	RPA610.300671	Share Blade LH	1	
x2	22016012/030	M12x30 CSK Socket Head Setscrew	3	
x2	22052012	M12 Spring Washer	3	
x2	22029012	M12 Full Nut	3	
3	RPA610.300672	Share Blade RH	1	
x3	22016012/030	M12x30 CSK Socket Head Setscrew	3	
x3	22052012	M12 Spring Washer	3	
x3	22029012	M12 Full Nut	3	
4	RPA610.300692	Share Blade RH	1	
x4	22016012/030	M12x30 CSK Socket Head Setscrew	3	
x4	22052012	M12 Spring Washer	3	
x4	22029012	M12 Full Nut	3	
5	RPA610.300693	Share Blade LH	1	
x5	22016012/030	M12x30 CSK Socket Head Setscrew	3	
x5	22052012	M12 Spring Washer	3	
x5	22029012	M12 Full Nut	3	
6	RPA610.310448	Stone Flap	4	
7	RPM146.300673	Stone Flap Pin	4	
8	RPGM100.03729	Adjuster Clevis	2	
9	RPM146.304702	Pin	2	

Machines from Serial No QM154

Shares Assemblies for Bed Work

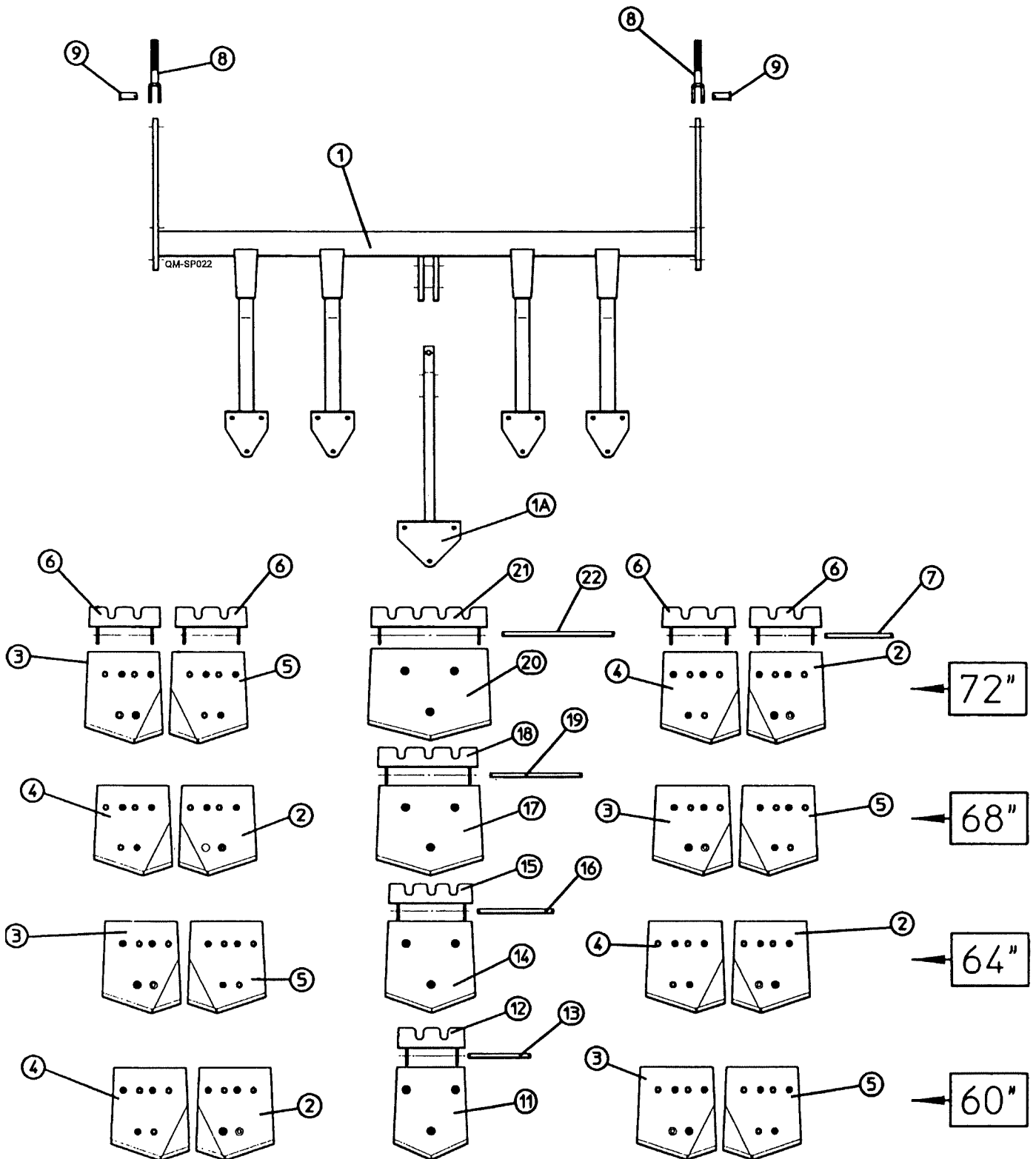

## 4.4a

## QUALITY MASTER SPARE PARTS

Machines from Serial No QM154

## Shares Assemblies for Bed Work

Item	Part No.	Description	Qty.	Remarks
1	RPA610.311065	Share Bar (1500mm)	1	
1a	RPA610.308521	Centre Share Arm	1	
2	RPA610.300671	Share Blade LH	1	
x2	22016012/030	M12x30 CSK Socket Head Setscrew	3	
x2	22052012	M12 Spring Washer	3	
x2	22029012	M12 Full Nut	3	
3	RPA610.300672	Share Blade RH	1	
x3	22016012/030	M12x30 CSK Socket Head Setscrew	3	
x3	22052012	M12 Spring Washer	3	
x3	22029012	M12 Full Nut	3	
4	RPA610.300692	Share Blade RH	1	
x4	22016012/030	M12x30 CSK Socket Head Setscrew	3	
x4	22052012	M12 Spring Washer	3	
x4	22029012	M12 Full Nut	3	
5	RPA610.300693	Share Blade LH	1	
x5	22016012/030	M12x30 CSK Socket Head Setscrew	3	
x5	22052012	M12 Spring Washer	3	
x5	22029012	M12 Full Nut	3	
6	RPA610.310448	Stone Flap	4	
7	RPM146.300673	Stone Flap Pin	4	
8	RPGM100.03729	Adjuster Clevis	2	
9	RPM146.304702	Pin	2	
10				
11	RPA610.300882	Centre Share Blade	1	
x11	22016012/030	M12x30 CSK Socket Head Setscrew	3	
x11	22052012	M12 Spring Washer	3	
x11	22029012	M12 Full Nut	3	
12	RPA610.310456	Stone Flap	1	
13	RPM146.300885	Stone Flap Pin	1	
14	RPA610.300886	Centre Share Blade	1	
x14	22016012/030	M12x30 CSK Socket Head Setscrew	3	
x14	22052012	M12 Spring Washer	3	
x14	22029012	M12 Full Nut	3	
15	RPA610.310454	Stone Flap	1	
16	RPM146.300889	Stone Flap Pin	1	
17	RPA610.300890	Centre Share Blade	1	
x17	22016012/030	M12x30 CSK Socket Head Setscrew	3	
x17	22052012	M12 Spring Washer	3	
x17	22029012	M12 Full Nut	3	
18	RPA610.310452	Stone Flap	1	
19	RPM146.300893	Stone Flap Pin	1	
20	RPA610.300894	Centre Share Blade	1	
x20	22016012/030	M12x30 CSK Socket Head Setscrew	3	
x20	22052012	M12 Spring Washer	3	



**QUALITY MASTER SPARE PARTS****4.4b**

Machines from Serial No QM154

**Shares Assemblies for Bed Work**

<b>Item</b>	<b>Part No.</b>	<b>Description</b>	<b>Qty.</b>	<b>Remarks</b>
x20	22029012	M12 Full Nut	3	
21	RPA610.310450	Stone Flap	1	
22	RPM146.300897	Stone Flap Pin	1	



Machines from Serial No QM158

**Shares Assemblies for Bed Work**

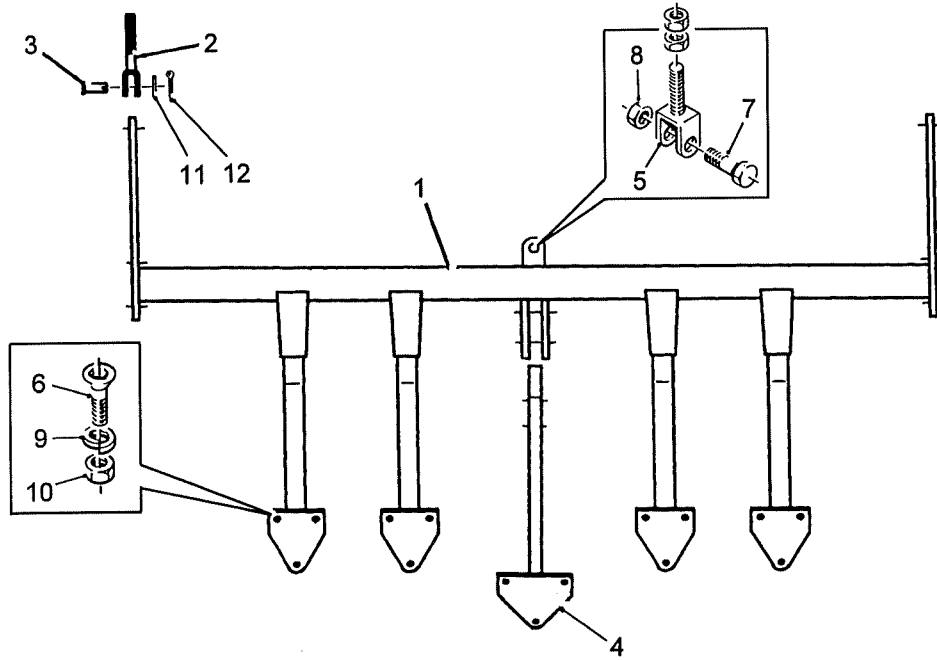

T2-SP024

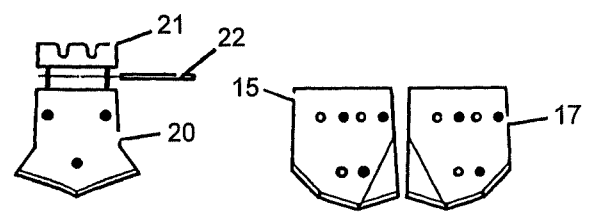
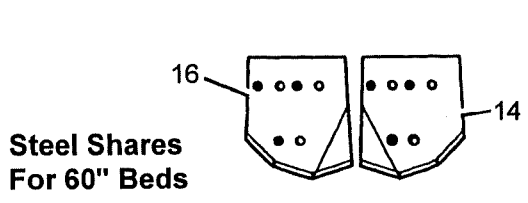
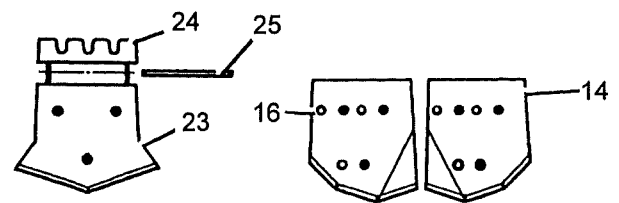
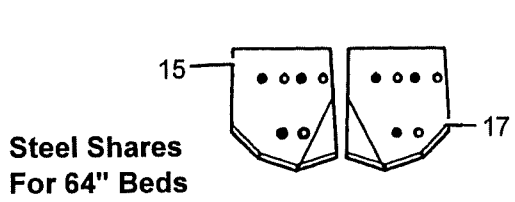
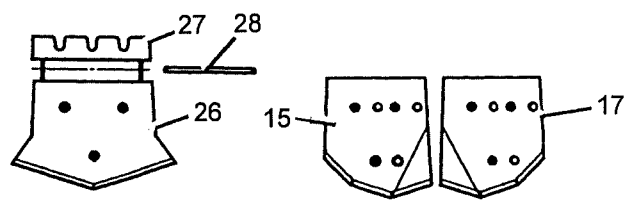
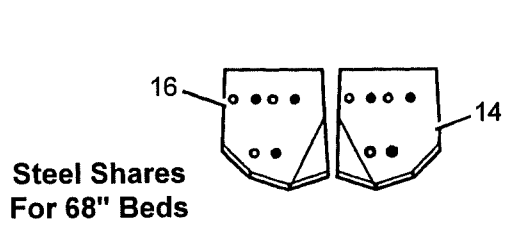
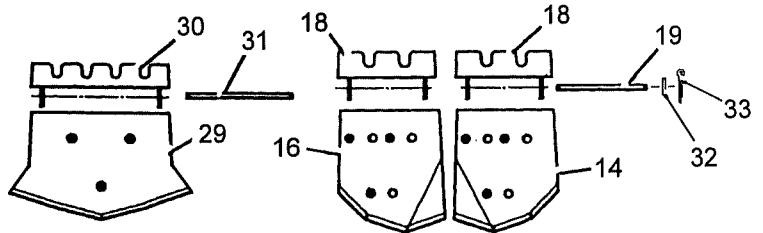
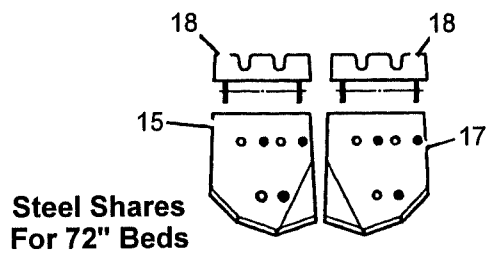

# 4.4a

# QUALITY MASTER SPARE PARTS

Machines from Serial No QM158

## Shares Assemblies for Bed Work

### Plastic Shares For 72" Beds

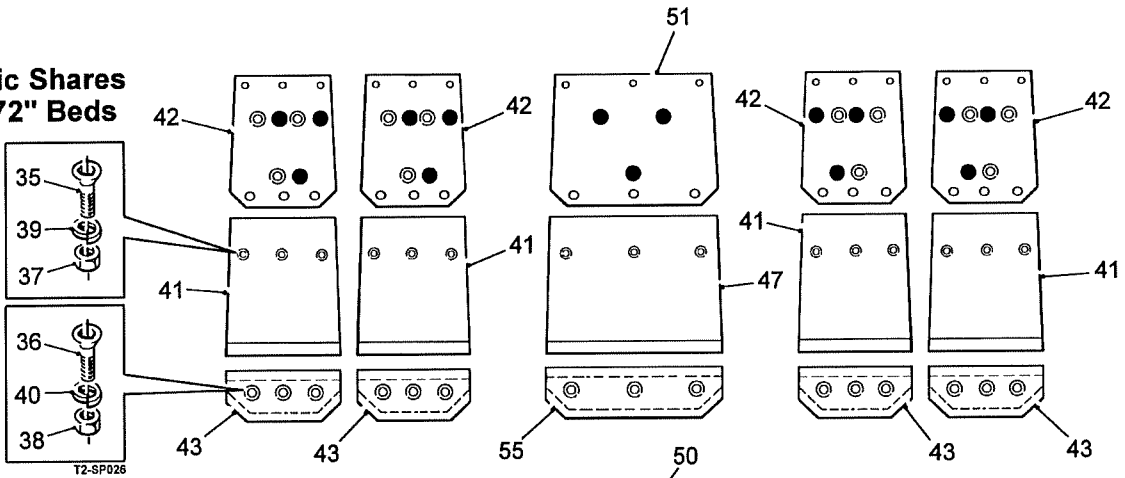

### Plastic Shares For 68" Beds

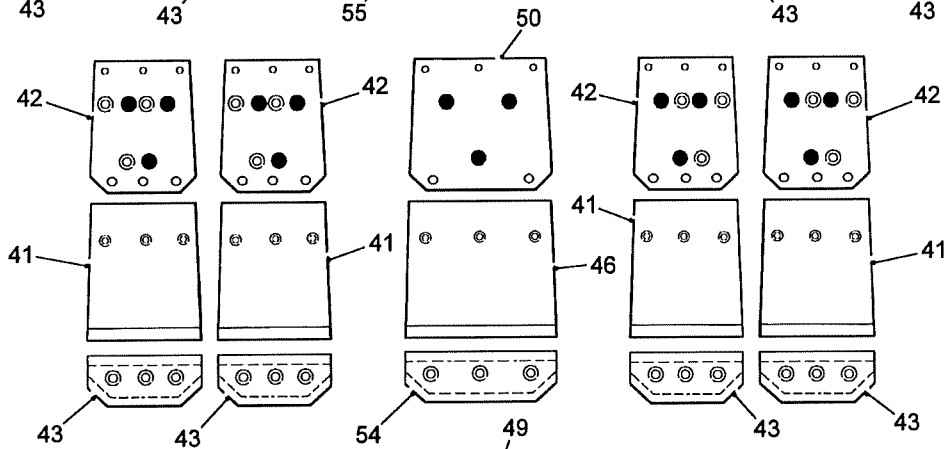

### Plastic Shares For 64" Beds

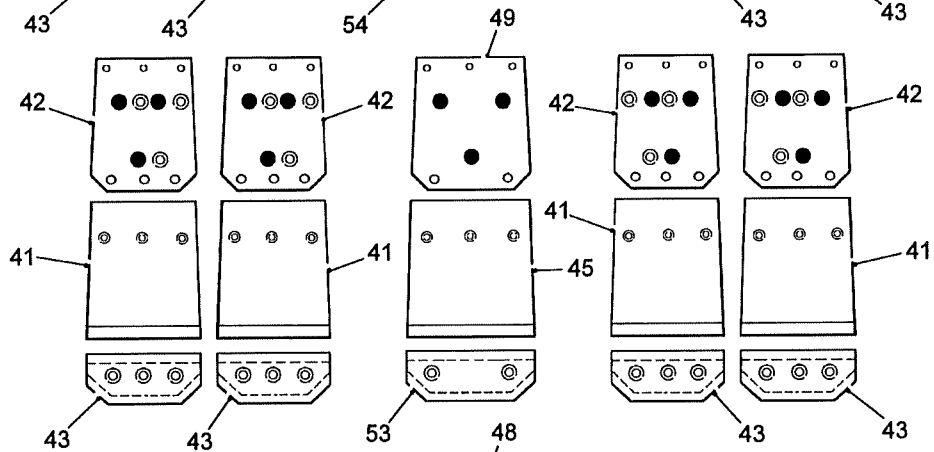

### Plastic Shares For 60" Beds

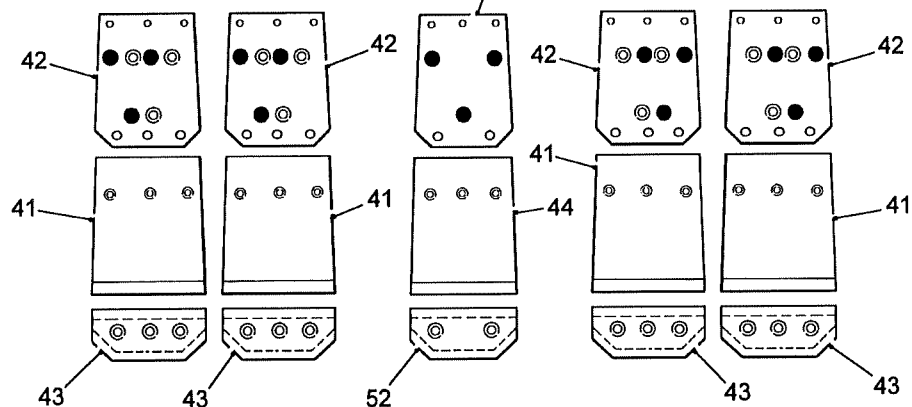

# QUALITY MASTER SPARE PARTS

4.4b

Machines from Serial No QM158

## Shares Assemblies for Bed Work

Item	Part No.	Description	Qty.	Remarks
1	RPA610.311065	Share Bar	1	
2	RPGM100.03729	Adjuster Clevis	2	
3	RPM146.304702	Retaining Pin	2	
4	RPS780	Bolt-on Share Arm	1	
5	RPS781	Share Arm Adjuster	1	
6	22016012/030	M12x30 CSK Socket Head Screw	15	Steel shares only
	22016012/040	M12x40 CSK Socket Head Screw	15	Plastic shares only
7	22012016/060	M16x60 Bolt	1	
8	22041016	M16 Nyloc Nut	1	
9	22052012	M12 Spring Washer	15	
10	22029012	M12 Full Nut	15	
11	22046020C	M20 Flat Washer	2	
12	22078005/040	Ø5x40 Split Pin	2	
13				
		<b>Steel Shares Consist Of:</b>		
14	RPA610.300671	Share Blade	1	
15	RPA610.300672	Share Blade	1	
16	RPA610.300692	Share Blade	1	
17	RPA610.300693	Share Blade	1	
18	RPA610.310448	Stone Flap	4	
19	RPM146.300673	Pivot Pin	4	
20	RPA610.300882	Centre Share Blade	1	60"beds
21	RPA610.310456	Stone Flap	1	60"beds
22	RPM146.300885	Pivot Pin	1	60"beds
23	RPA610.300886	Centre Share Blade	1	64"beds
24	RPA610.310454	Stone Flap	1	64"beds
25	RPM146.300889	Pivot Pin	1	64"beds
26	RPA610.300890	Centre Share Blade	1	68"beds
27	RPA610.310452	Stone Flap	1	68"beds
28	RPM146.300893	Pivot Pin	1	68"beds
29	RPA610.300894	Centre Share Blade	1	72"beds
30	RPA610.310450	Stone Flap	1	72"beds
31	RPM146.300897	Pivot Pin	1	72"beds
32	22046012C	M12 Flat Washer	10	
33	22078004/022	Ø4x22 Split Pin	10	
34				
		<b>Plastic Shares Consist Of:</b>		
35	22016008/040	M8x40 CSK Socket Head Screw	15	
36	22016012/040	M12x40 CSK Socket Head Screw	15	Qty x14 on 60"&64"beds
37	22029008	M8 Full Nut	15	
38	22029012	M12 Full Nut	15	Qty x14 on 60"&64"beds
39	22052008	M8 Spring Washer	15	
40	22052012	M12 Spring Washer	15	Qty x14 on 60"&64"beds
41	RPC730.308943	Plastic Share Blade	4	
42	RPM226.308941	Steel Profile	4	
43	RPW242.308942	Share Tip	4	
44	RPC730.308946	Centre Plastic Share Blade	1	60"beds
45	RPC730.308949	Centre Plastic Share Blade	1	64"beds
46	RPC730.308952	Centre Plastic Share Blade	1	68"beds
47	RPC730.308955	Centre Plastic Share Blade	1	72"beds

**4.4c****QUALITY MASTER SPARE PARTS**

Machines from Serial No QM158

**Shares Assemblies for Bed Work**

<b>Item</b>	<b>Part No.</b>	<b>Description</b>	<b>Qty.</b>	<b>Remarks</b>
48	RPM226.308944	Centre Steel Profile	1	60"beds
49	RPM226.308947	Centre Steel Profile	1	64"beds
50	RPM226.308950	Centre Steel Profile	1	68"beds
51	RPM226.308953	Centre Steel Profile	1	72"beds
52	RPW242.308945	Centre Share Tip	1	60"beds
53	RPW242.308948	Centre Share Tip	1	64"beds
54	RPW242.308951	Centre Share Tip	1	68"beds
55	RPW242.308954	Centre Share Tip	1	72"beds

Machines from Serial No QM154

Anti Roll-back Flaps

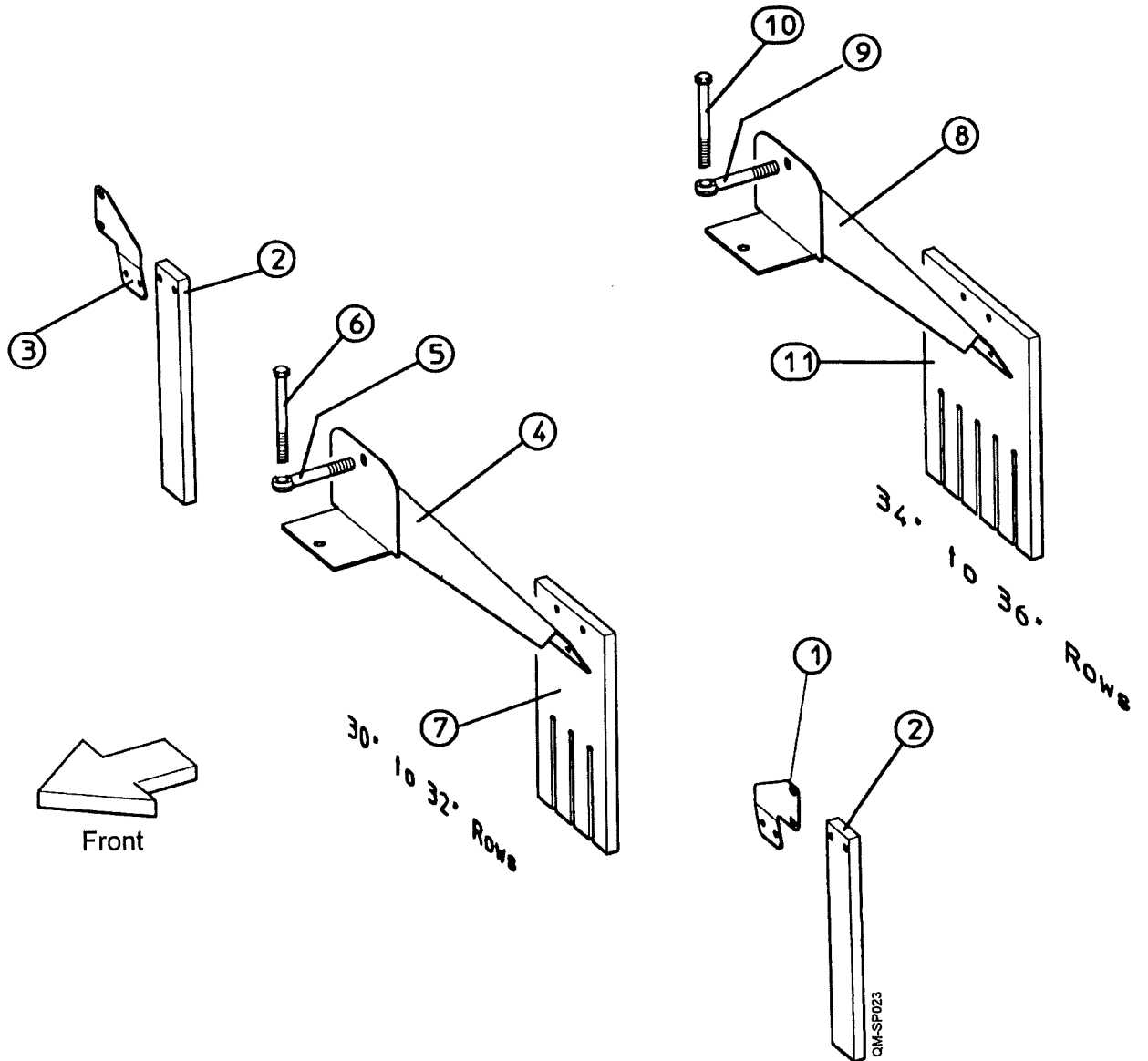

**4.5a****QUALITY MASTER SPARE PARTS**

Machines from Serial No QM154

**Anti Roll-back Flaps**

Item	Part No.	Description	Qty.	Remarks
1	RPM225.306296	Flap Mounting Outer LH	1	
2	RPC700.306301	Flap Outer	2	
3	RPM225.306297	Flap Mounting Outer RH	1	
4	RPA610.306300	Flap Mounting Centre (30"-32"rows)	1	
5	RPF100.116095	M16x95 Eye Bolt	1	
6	22012016/150	M16x150 Bolt	1	
7	RPC730.306302	Flap Centre (30"-32"rows)	1	
8	RPA610.306300	Flap Mounting Centre (34"-36"rows)	1	
9	RPF100.116095	M16x95 Eye Bolt	1	
10	22012016/150	M16x150 Bolt	1	
11	RPC730.306757	Flap Centre (34"-36"rows)	1	



Machines from Serial No QM154

**Floating Chassis Assembly**

Assy No RPS525

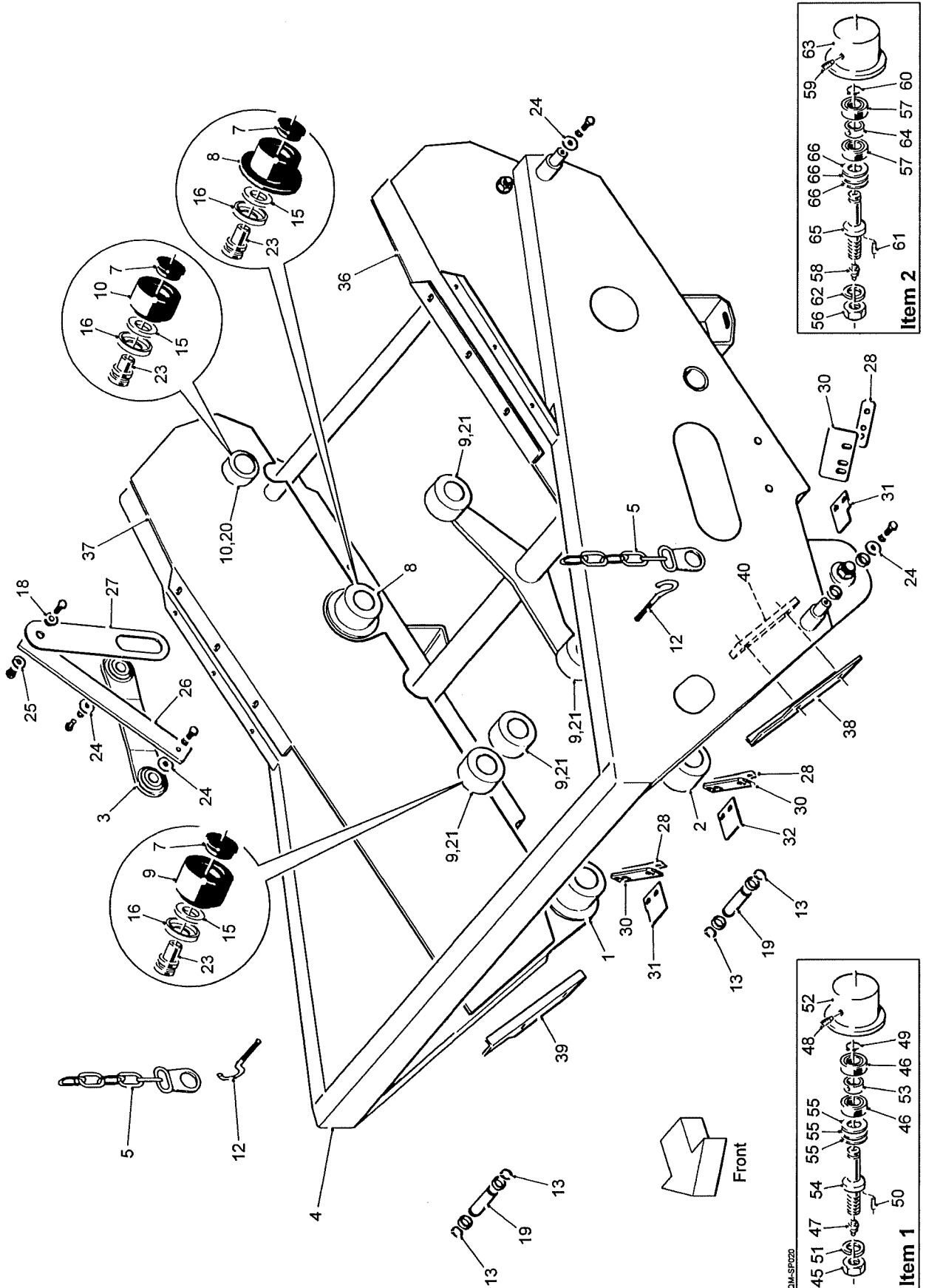

## 4.6a

## QUALITY MASTER SPARE PARTS

Machines from Serial No QM154

## Floating Chassis Assembly

Assy No RPS525

Item	Part No.	Description	Qty.	Remarks
1	RPA510.308681	Flanged Roller Assembly	2	(see list at end)
2	RPA510.308684	Plain Roller Assembly	1	(see list at end)
3	RPA610.304043	Tie Bar	1	
4	RPA610.305760	Floating Chassis	1	
5	RPA610.306878	Chain	2	
6				
7	RPC620.303070	Cap	10	
8	RPC700.300146	Ø95 Flanged Roller c/w Bearings	2	
9	RPC700.300147	Ø95 Plain Roller c/w Bearings	6	
10	RPC700.300148	Ø75 Plain Roller c/w Bearings	2	
11				
12	RPF128.306073	Hook Bolt	2	
13	RPF200.025200	Ø25 External Circlip	4	
14				
15	RPGM070.00446	Felt Seal	10	
16	RPGM089.00565	Roller Shield	10	
17				
18	RPM114.304206	Collar	1	
19	RPM146.306263	Pin	2	
20	RPM176.306318	Spacer (20mm)	2	
21	RPM176.306319	Spacer (10mm)	6	
22				
23	RPM180.303071	Roller Spindle	10	
24	RPM196.300794	Retaining Washer	5	
25	RPM196.304296	Washer	1	
26	RPM252.306898	Stay	1	
27	RPM254.304207	Strap	1	
28	RPM256.300133	Clamp Strip	3	
29				
30	RPW240.300134	Nylon Scraper	3	
31	RPW240.300135	Roller Scraper	2	
32	RPW240.300445	Roller Scraper Centre	1	
33				
34				
35				
36	RPS1189	Stainless Side Panel LH	1	
37	RPS1190	Stainless Side Panel RH	1	
38	RPS1191	Stainless Panel Clamp Plate LH	1	
39	RPS1192	Stainless Panel Clamp Plate RH	1	
40	RPS1250	Securing Strip	2	
	<b>RPA510.308681</b>	<b>Flanged Roller Assembly Consists Of:</b>		
45	22029024	M24 Full Nut	1	
46	6205	Bearing	2	
47	RC648.081250	M8 Grease Nipple	1	
48	RPF136.308016	M8x16 Dog Screw	1	
49	RPF200.025200	Ø25 External Circlip	1	
50	RPF222.060016	Ø6x16 Groove Pin	1	
51	RPF290.124000	M24 Shakeproof Washer	1	
52	RPGM001.00180	Flanged Steel Roller	1	
53	RPM176.307416	Spacer	1	
54	RPM180.307415	Spindle	1	
55	RPS210.002052	Metal Seal	3	

**QUALITY MASTER SPARE PARTS****4.6b**

Machines from Serial No QM154

**Floating Chassis Assembly****Assy No RPS525**

Item	Part No.	Description	Qty.	Remarks
	<b>RPA510.308684</b>	<b>Plain Roller Assembly Consists Of:</b>		
56	22029024	M24 Full Nut	1	
57	6205	Bearing	2	
58	RPC648.081250	M8 Grease Nipple	1	
59	RPF136.308016	M8x16 Dog Screw	1	
60	RPF200.025200	Ø25 External Circlip	1	
61	RPF222.060016	Ø6x16 Groove Pin	1	
62	RPF290.124000	M24 Shakeproof Washer	1	
63	RPGM001.00059	Plain Steel Roller	1	
64	RPM176.307416	Spacer	1	
65	RPM180.307415	Spindle	1	
66	RPS210.002052	Metal Seal	3	



Machines from Serial No QM154

Agitator Assembly  
Assy No 67106

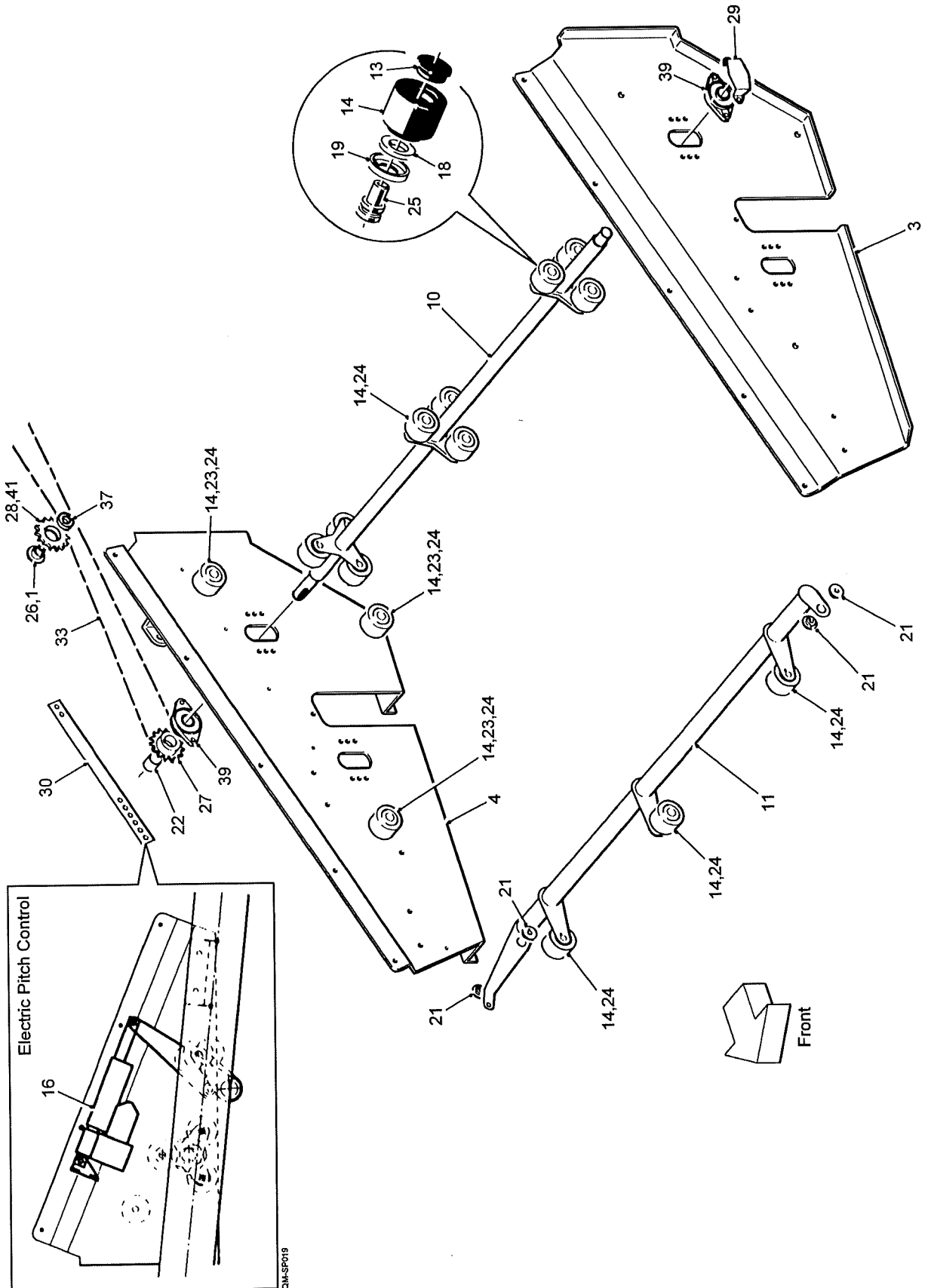

## 4.7a

## QUALITY MASTER SPARE PARTS

Machines from Serial No QM154

## Agitator Assembly

Assy No 67106

Item	Part No.	Description	Qty.	Remarks
1	12298	Ø20 External Circlip	1	
2				
3	67016	Agitator Plate LH	1	
4	67017	Agitator Plate RH	1	
5				
6				
7				
8				
9				
10	RPA610.305728	Agitator Shaft	1	
11	RPA610.307188	Control Arm	1	
12				
13	RPC620.303070	Cap	18	
14	RPC700.300148	Ø75 Plain Roller c/w Bearings	18	
15				
16	RPE202.305394	Linear Actuator c/w Switch & Harness	1	Optional
17				
18	RPGM070.00446	Felt Seal	18	
19	RPGM089.00565	Roller Shield	18	
20				
21	RPM106.304349	Pivot Boss	4	
22	RPM176.300356	Spacer (35mm)	1	
23	RPM176.306318	Spacer (20mm)	12	
24	RPM176.306319	Spacer (10mm)	18	
25	RPM180.303071	Roller Spindle	18	
26	RPM180.305086	Spindle	1	
27	RPM182.300348	15T 3/4"Pitch Sprocket	1	
28	RPM182.306353	15T 3/4"Pitch Idler Sprocket	1	
29	RPM216.301080	End Guard	1	
30	RPM254.304314	Agitator Strap	1	
31				
32				
33	RPT732.620114	3/4"Pitch Drive Chain	1	Agitator in rear position
	RPT732.620157	3/4"Pitch Drive Chain	1	Agitator in front position
34				
35				
36				
37	62042RS	Bearing	1	
38				
39	SFT30	Bearing	2	
40				
41	W0113	Ø47 Internal Circlip	1	

Machines from Serial No QM154

Main Web & Haulm Roller  
Assy No 67104

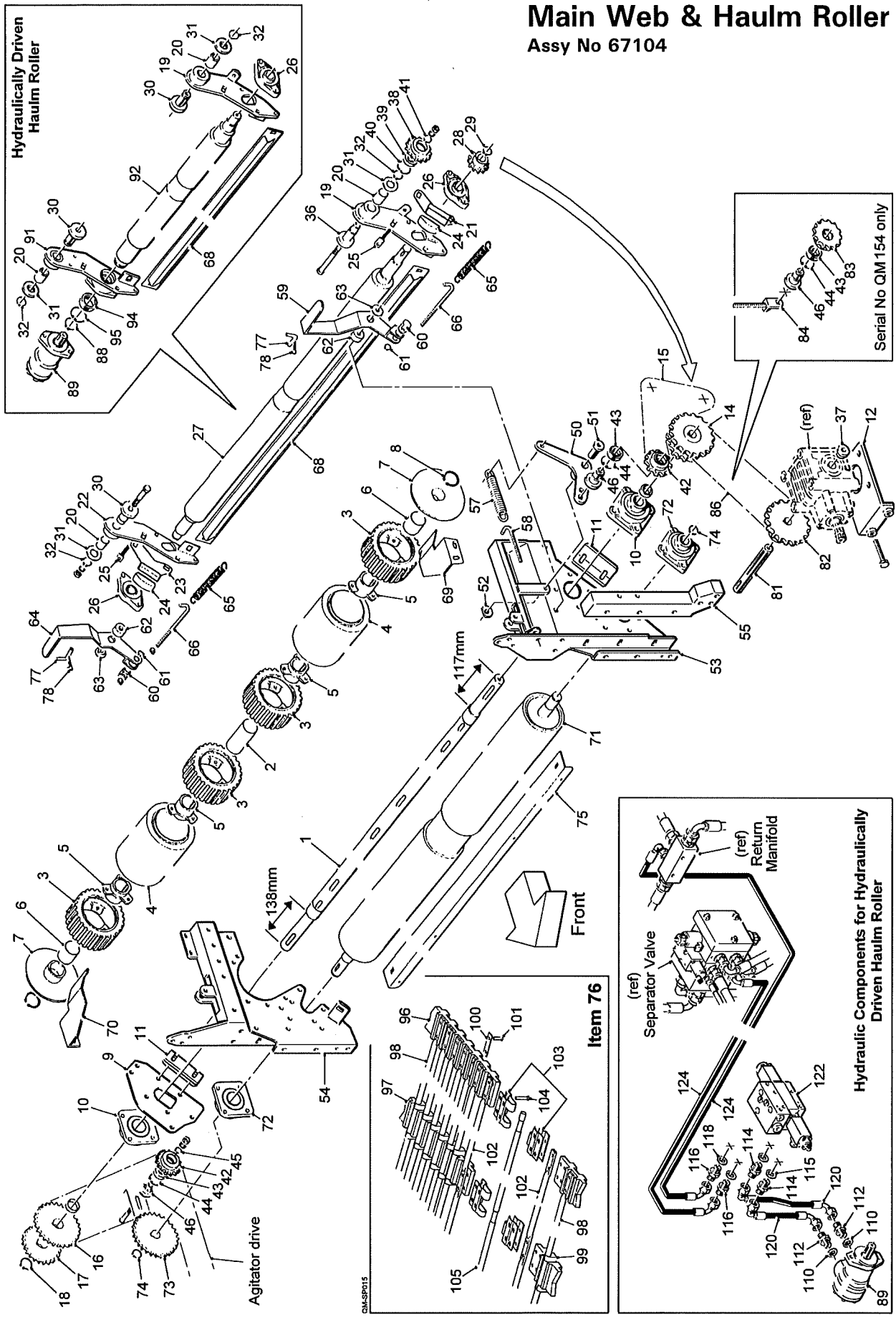

## 4.8a

## QUALITY MASTER SPARE PARTS

Machines from Serial No QM154

## Main Web &amp; Haulm Roller

Assy No 67104

Item	Part No.	Description	Qty.	Remarks
1	67063	Drive Shaft	1	
2	RPM176.300781	Spacer Tube (128mm)	1	
3	RPC700.301267	Drive Roller	4	
4	RPA510.303920	Roller	2	
x4	RPF162.116080	M16x80 Stud	4	
5	RPGM006.00482	Drive Roller Hub	4	
6	RPM176.300780	Spacer Tube	2	
7	RPM124.302284	Flange	2	
8	RPF200.050300	Ø50 External Circlip	2	
9	67200	Bearing Mounting plate	1	Was RPM225.305724
10	SF40	Ø40 Bearing	2	
11	67213	Haulm Roller Stop	2	Was RPM225.306729 x1
12	67201	Gearbox Mounting Plate	1	
13				
14	67109	28T 3/4"x24T 1" Double Sprocket	1	
x14	RPF210.121040	12x10x40 RBE Key	1	
15	RPT732.620068	3/4"Pitch Drive Chain	1	
16	RPM182.306278	28T 3/4"Pitch Sprocket	1	
17	RPM182.306279	24T 3/4"Pitch Sprocket	1	
x17	RPF210.121060	12x10x60 RBE Key	1	
18	RPF200.040250	Ø40 External Circlip	1	
19	RPA610.305954	Haulm Roller Mounting Plate LH	1	
20	RPB250.303440	Bush	2	
21	RPA610.301739	Haulm Roller Adjuster Stop LH	1	
22	RPA610.305955	Haulm Roller Mounting Plate RH	1	
23	RPA610.301740	Haulm Roller Adjuster Stop RH	1	
24	RPC648.301660	Buffer Block	2	
25	RPA610.301753	Adjuster	2	
26	SFT30	Ø30 Bearing	2	
27	RPC700.305732	Haulm Roller (chain driven)	1	
28	RPM182.300354	12T 3/4"Pitch Sprocket	1	
29	RPF200.030200	Ø30 External Circlip	2	
30	RPM178.305900	Spigot	1	Hydraulic drive Qty x2
31	22046030B	M30 Flat Washer	2	
32	RPF200.030200	Ø30 External Circlip	2	
33				
34				
35				
36	RPM178.305901	Spigot	1	
37	RPM178.306259	Spigot	1	
38	RPM182.300390	15T 3/4"Pitch Sprocket	1	
39	62053RS	Bearing	1	
40	W0167	Ø52 Internal Circlip	1	
41	RPF200.025200	Ø25 External Circlip	1	
42	RPM182.306353	15T 3/4"Pitch Sprocket	2	
43	62042RS	Bearing	1	
44	W0113	Ø47 Internal Circlip	1	
45	12298	Ø20 External Circlip	2	
46	RPM180.305086	Spindle	2	Serial No QM154 only
47				
48				
49				
50	67113	Chain Tensioner	1	
51	67114	Pivot Boss	1	
52	67399	'D' Washer	1	



# QUALITY MASTER SPARE PARTS

4.8b

Machines from Serial No QM154

## Main Web & Haulm Roller

Assy No 67104

Item	98Part No.	Description	Qty.	Remarks
53	67018	Web Drive Mount LH	1	Machine with Omega
54	67019	Web Drive Mount RH	1	Machine with Omega
55	67236	Side Mounting Bracket	1	
56				
57	RPC676.304679	Tension Spring	1	
58	RPF128.110130	M10x130 Hook Bolt	1	
59	67022	Haulm Roller Release Arm LH	1	
60	RPM148.301746	Spring Mounting	2	
61	RPF200.020175	Ø20 External Circlip	2	
62	RPM176.305902	Spacer	2	
63	RPM106.304349	Boss	2	
64	67023	Haulm Roller Release Arm RH	1	
65	RPC676.304679	Tension Spring	2	
66	RPF128.110130A	M10x165 Hook Bolt	2	Was RPF128.110130
67				
68	RPA610.306203	Scraper	1	
69	RPW240.303714	Scraper LH	1	
70	RPW240.303715	Scraper RH	1	
71	RPC700.305979	Nip Roller	1	
72	SF35	Ø35 Bearing	2	
73	RPM182.306277	28T 3/4"Pitch Sprocket	1	
74	RPF200.035250	Ø35 External Circlip	2	
75	RPM225.306029	Scraper	1	
76	RPW300.306195	28mm Pitch Web Assembly	1	(see list at end)
	67103/32	32mm Pitch Web Assembly	1	(see list at end)
	RPW300.306196	35mm Pitch Web Assembly	1	(see list at end)
	RPW300.306197	40mm Pitch Web Assembly	1	(see list at end)
	RPW300.306198	45mm Pitch Web Assembly	1	(see list at end)
	RPW300.306199	50mm Pitch Web Assembly	1	(see list at end)
			1	
77	RPM146.306389	Ø12 Pin	2	
78	S86-82-002	Ø3x66 Grip Clip	2	
79				
80				
81	67064	Gearbox Drive Shaft	1	
82	67108	24T 1"Pitch Sprocket (standard)	1	100% digger speed
	67299	18T 1"Pitch Sprocket	1	75% digger speed
	67298	16T 1"Pitch Sprocket	1	66% digger speed
83	67110	15T 1"Pitch Tensioner Sprocket	1	Serial No QM154 only
84	67111	Tensioner	1	Serial No QM154 only
85				
86	-	1"Pitch Drive Chain	1	
87				
88	33130/16	Ø50 External Circlip	1	
89	44563	Hydraulic Motor	1	
90				
91	67273	Haulm Roller Motor Mounting	1	
92	67275	Haulm Roller (hydraulic driven)	1	

## 4.8c

## QUALITY MASTER SPARE PARTS

Machines from Serial No QM154

## Main Web &amp; Haulm Roller

Assy No 67104

Item	Part No.	Description	Qty.	Remarks
93				
94	60102RS	Bearing	1	
95	W0161	Ø80 Internal Circlip	1	
	<b>RPW300.306195</b>	<b>28mm Pitch Web Assy Consists Of:</b>		
96	-	Side Belt	2	
97	-	Centre Belt	1	
98	RPM432.309185	Ø10 Web Rod	250	
99	RPGM002.00405	Centre Clip	250	
100	RPGMRP019.00002	Back Plate	500	
101	RF240.150250	Rivet For Back Plate	1000	
102	RPM432.309186	Ø10 Web Rod Under Joiner	2	
103	RPM419.162832	28mm Pitch Joiner (2 hole)	3 pairs	
104	RPF240.150300	Rivet For Joiner	12	
105	RPM432.309187	Ø10 Joining Rod	1	
	<b>67103/32</b>	<b>32mm Pitch Web Assy Consists Of:</b>		
96	-	Side Belt	2	
97	-	Centre Belt	1	
98	RPM432.309185	Ø10 Web Rod	220	
99	RPGM002.00405	Centre Clip	220	
100	RPGMRP019.00002	Back Plate	440	
101	RF240.150250	Rivet For Back Plate	880	
102	RPM432.309186	Ø10 Web Rod Under Joiner	2	
103	RPM419.364032	32mm Pitch Joiner (2 hole)	3 pairs	
104	RPF240.150300	Rivet For Joiner	12	
105	RPM432.309187	Ø10 Joining Rod	1	
	<b>RPW300.306196</b>	<b>35mm Pitch Web Assy Consists Of:</b>		
96	-	Side Belt	2	
97	-	Centre Belt	1	
98	RPM432.309185	Ø10 Web Rod	199	
99	RPGM002.00405	Centre Clip	199	
100	RPGMRP019.00002	Back Plate	398	
101	RF240.150250	Rivet For Back Plate	796	
102	RPM432.309186	Ø10 Web Rod Under Joiner	2	
103	RPM419.363532	35mm Pitch Joiner (4 hole)	3 pairs	
104	RPF240.150300	Rivet For Joiner	24	
105	RPM432.309187	Ø10 Joining Rod	1	
	<b>RPW300.306197</b>	<b>40mm Pitch Web Assy Consists Of:</b>		
96	-	Side Belt	2	
97	-	Centre Belt	1	
98	RPM432.309190	Ø12 Web Rod	174	
99	RPGM002.00430	Centre Clip	174	
100	RPGMRP019.00002	Back Plate	348	
101	RF240.150250	Rivet For Back Plate	696	
102	RPM432.309188	Ø12 Web Rod Under Joiner	2	
103	RPM419.364032	40mm Pitch Joiner (4 hole)	3 pairs	
104	RPF240.150300	Rivet For Joiner	24	
105	RPM432.309187	Ø10 Joining Rod	1	

# QUALITY MASTER SPARE PARTS

4.8d

Machines from Serial No QM154

## Main Web & Haulm Roller

Assy No 67104

Item	Part No.	Description	Qty.	Remarks
	<b>RPW300.306198</b>	<b>45mm Pitch Web Assy Consists Of:</b>		
96	-	Side Belt	2	
97	-	Centre Belt	1	
98	RPM432.309190	Ø12 Web Rod	154	
99	RPGM002.00430	Centre Clip	154	
100	RPGMRP019.00002	Back Plate	308	
101	RF240.150250	Rivet For Back Plate	616	
102	RPM432.309188	Ø12 Web Rod Under Joiner	2	
103	RPM419.364432	44mm Pitch Joiner (4 hole)	3 pairs	
104	RPF240.150300	Rivet For Joiner	24	
105	RPM432.309187	Ø10 Joining Rod	1	
	<b>RPW300.306199</b>	<b>50mm Pitch Web Assy Consists Of:</b>		
96	-	Side Belt	2	
97	-	Centre Belt	1	
98	RPM432.309190	Ø12 Web Rod	138	
99	RPGM002.00430	Centre Clip	138	
100	RPGMRP019.00002	Back Plate	276	
101	RF240.150250	Rivet For Back Plate	552	
102	RPM432.309188	Ø12 Web Rod Under Joiner	2	
103	RPM419.365032	50mm Pitch Joiner (4 hole)	3 pairs	
104	RPF240.150300	Rivet For Joiner	24	
105	RPM432.309187	Ø10 Joining Rod	1	
		<b>Hydraulic Components for Hydraulically Driven Haulm Roller Consist Of:</b>		
110	11124	1/2"BSP Dowty Seal	2	
111				
112	12315	1/2"BSP M M Adaptor	2	
113				
114	27459	M18x1/2"BSP M M Adaptor	2	
115	27461	M18 Dowty Seal	2	
116	31168	M22x1/2"BSP M M Adaptor	2	
117				
118	31167	M22 Dowty Seal	2	
119				
120	41185	1/2"Hose Assembly (800mm)	2	
121				
122	56619	Valve Assembly	1	
123				
124	60214	1/2"Hose Assembly (2550mm)	2	



Machines from Serial No QM154

**Haulm Feed Fingers**  
Assy No 67122

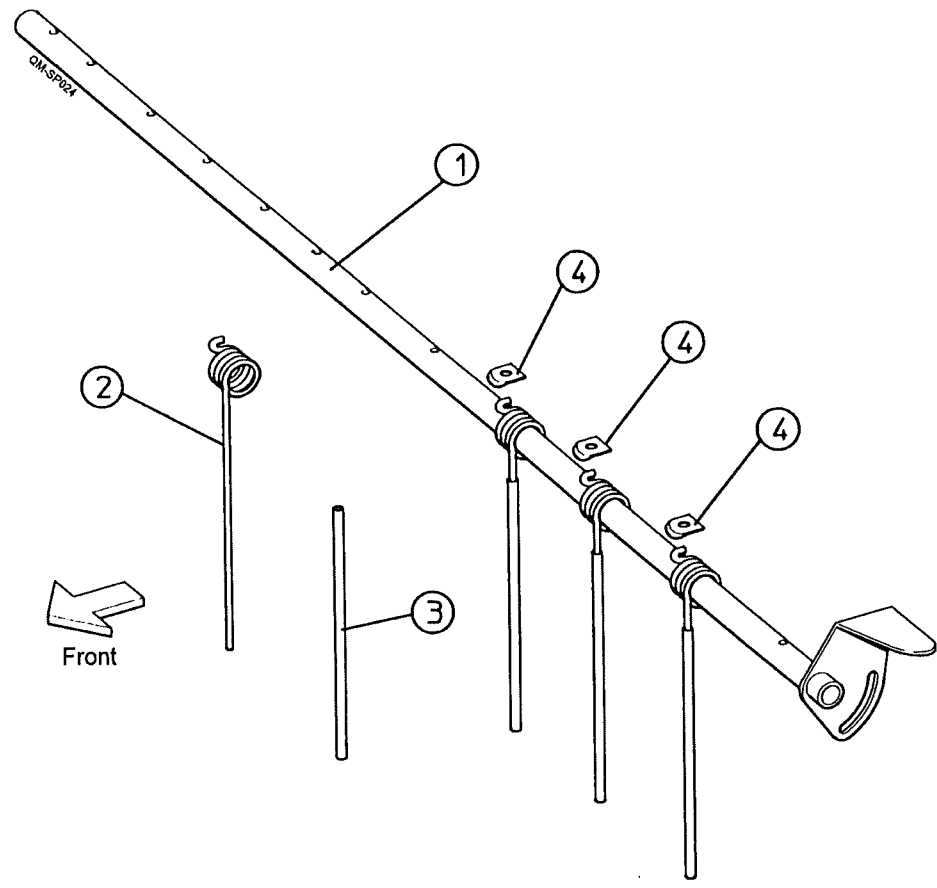

**4.9a****QUALITY MASTER SPARE PARTS**

Machines from Serial No QM154

**Haulm Feed Fingers****Assy No 67122**

<b>Item</b>	<b>Part No.</b>	<b>Description</b>	<b>Qty.</b>	<b>Remarks</b>
1	67085	Finger Mounting	1	
2	RPC677.306738	Spring Haulm Finger	12	
3	RPC740.306742	Finger Cover	12	
x3	RPC654.306743	Hose Clip	12	
4	RPM196.306540	Clip Washer	12	

Machines from Serial No QM154

**Centre Disc Coulters**  
Assy No 67324

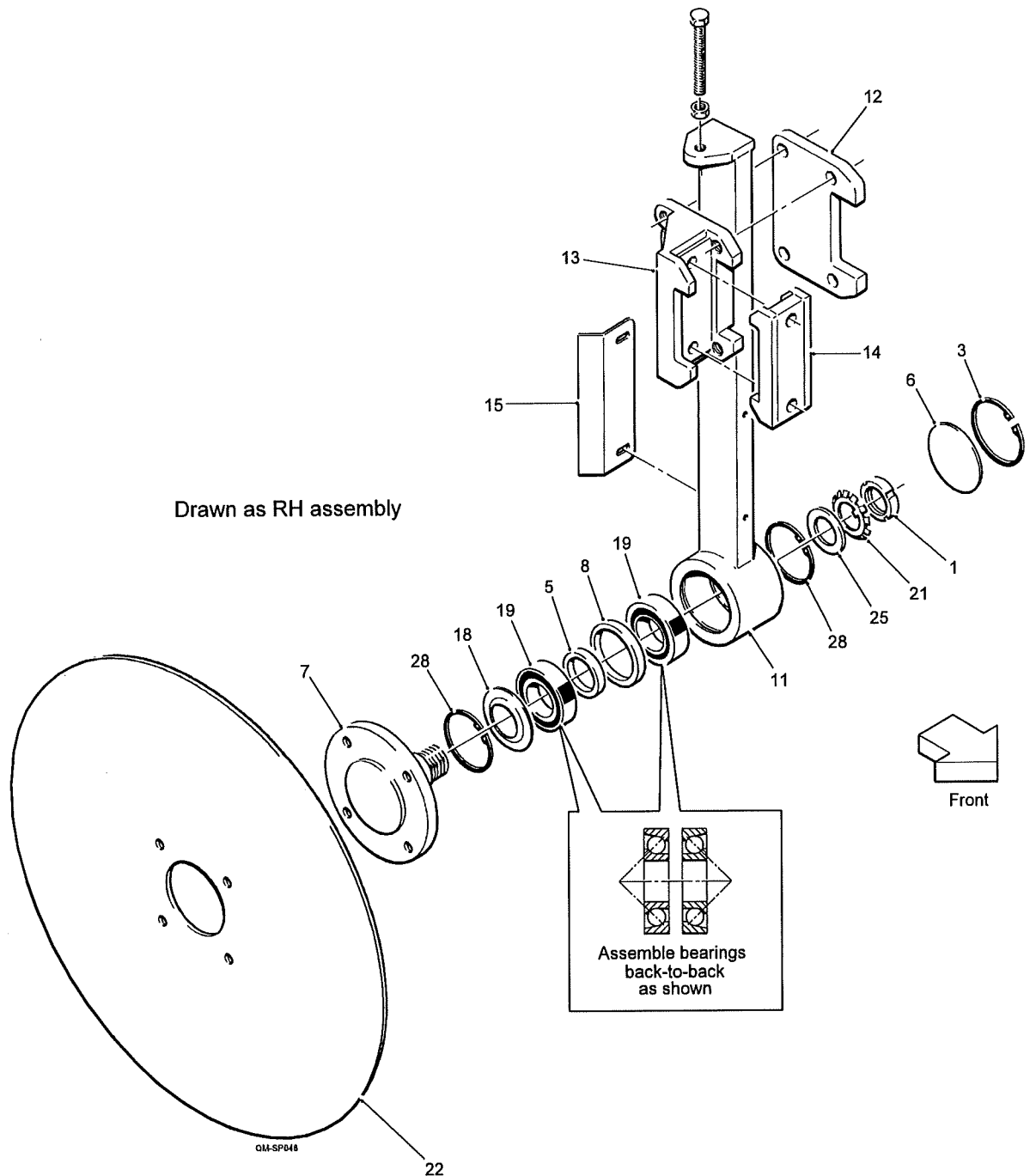

**4.10****QUALITY MASTER SPARE PARTS**

Machines from Serial No QM154

**Centre Disc Coulters****Assy No 67324**

Item	Part No.	Description	Qty.	Remarks
1	45038	M40 Locknut	2	
2				
3	46564	Ø90 Internal Circlip	2	
4				
5	64189	Bearing Spacer Inner	2	
6	64190	Dust Cap	2	
7	64977	Disc Spindle	2	
8	64978	Bearing Spacer Outer	2	
9				
10				
11	67319	Disc Arm	2	
12	67320	Clamp Plate	2	
13	67321	Fixing Bracket	2	
14	67322	Clamp Bracket	2	
15	67323	Scraper	2	
16				
17				
18	6209ZJV	Nilos Ring	2	
19	72092RS	Bearing	4	
20				
21	RPF284.140000	Lock Washer	2	
22	RPGM089.00018	Disc Ø645	2	
23				
24				
25	SS060041/003	Steel Spacer	2	
26				
27				
28	W0554	Ø85 Internal Circlip	4	



Machines from Serial No QM154

5R Omega Separator (237mm centres)

Assy No 67094

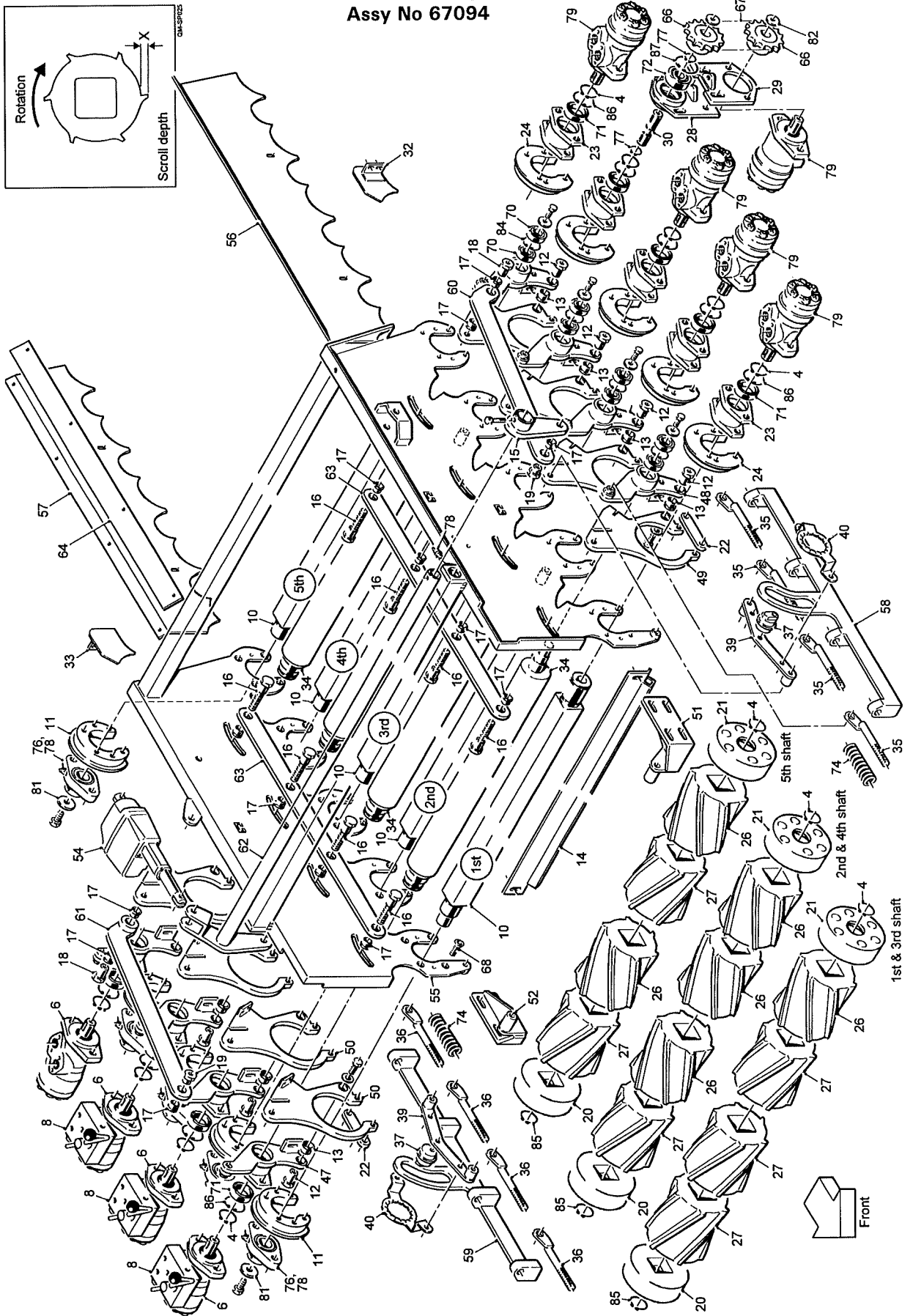

# 5.1a

# QUALITY MASTER SPARE PARTS

Machines from Serial No QM154

## 5R Omega Separator (237mm centres)

Assy No 67094

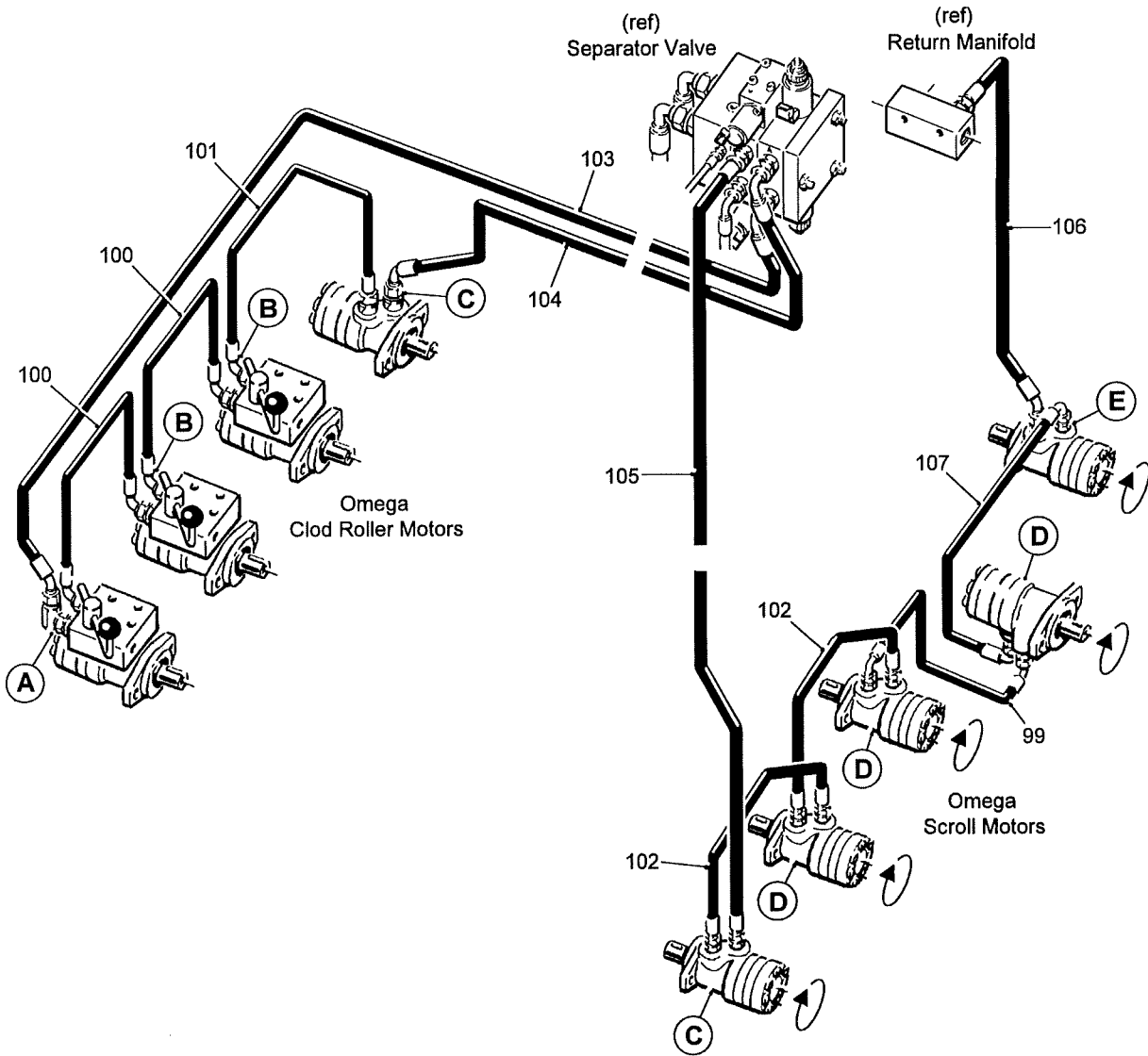

QM-SP035

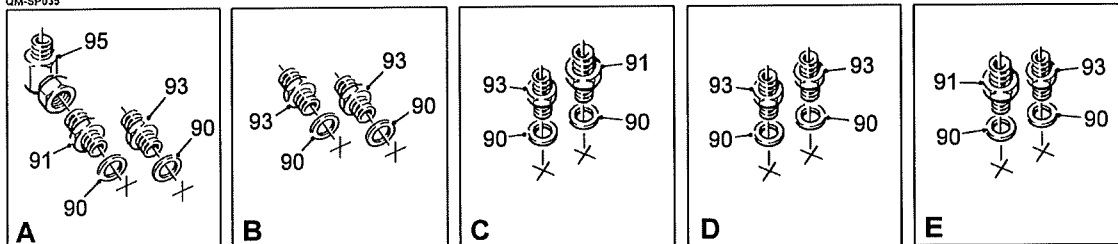

# QUALITY MASTER SPARE PARTS

5.1b

Machines from Serial No QM154

## 5R Omega Separator (237mm centres)

Assy No 67094

Item	Part No.	Description	Qty.	Remarks
1				
2				
3				
4	33130/16	Ø50 External Circlip	14	
5				
6	44563	Hydraulic Motor	4	
7				
8	56112	Diverter Valve	3	
9				
10	59136A/1400	Scroll Shaft	5	
11	59143	Bearing Boss	5	
12	59162	Pivot Pin	8	
13	59163	Pivot Flange Bush	8	
14	59164/1400	Clod Roller Scraper	4	
15	59166	Clod Roller Lift Arm	1	
16	59174	Shoulder Bolt (long)	8	
17	59175	Pivot Flange Bush	14	
18	59176	Tapped Boss (long)	2	
19	59177	Tapped Boss (short)	2	
20	59348	Male End Cap (Ø45 bore)	5	
21	59348A	Male End Cap (Ø50 bore)	5	
22	59352	Carrier Plate Tie	8	
23	59529	Motor Mount	5	
24	59928	Bearing Boss	5	
25				
26	59934C	LH Cavity Scroll (x = 10mm)	20	LH Solid Scroll 59934S
	59936C	LH Cavity Scroll (x = 6mm)	20	LH Solid Scroll 59936S
27	59935C	RH Cavity Scroll (x = 10mm)	20	RH Solid Scroll 59935S
	59937C	RH Cavity Scroll (x = 6mm)	20	RH Solid Scroll 59937S
28	56814	Adapter Plate	1	
29	56815	Motor Plate	1	
30	56816	Coupling Shaft	1	
31				
32	62652	LH Deflector Plate (short)	4	
33	62653	RH Deflector Plate (short)	4	
34	62863/1400	Rubber Clod Roller	4	
35	62903	LH Adjuster	4	
36	62904	RH Adjuster	4	
37	62908	Adjuster Boss	2	
38				
39	62913	Adjuster Plate	2	
40	62914	Indicator Plate	2	
41				
42				
43				
44	64747	Pivot Boss	2	
45				
46				
47	64046	Clod Roller Motor Mount	4	
48	64047	Clod Roller Bearing Mount	4	

## 5.1c

## QUALITY MASTER SPARE PARTS

Machines from Serial No QM154

5R Omega Separator (237mm centres)

Assy No 67094

Item	Part No.	Description	Qty.	Remarks
49	64066	LH Carrier Plate	4	
50	64067	RH Carrier Plate	4	
51	64093	Pivot Bracket LH	1	
52	64094	Pivot Bracket RH	1	
53				
54	67002	Linear Actuator	1	
55	67005	4R Omega Frame (237mm centres)	1	
56	67006	Stainless Side Panel LH	1	
57	67007	Stainless Side Panel RH	1	
58	67008	Adjuster Strap LH	1	
59	67009	Adjuster Strap RH	1	
60	67010	Link LH	1	
61	67011	Link RH	1	
62	67012	Clod Roller Lift Shaft	1	
63	67013	Link (237mm centres)	2	
64				
65				
66	RPM182.306832	15T 3/4"Pitch Sprocket	2	
67				
68	22016010/020	M10x20 CSK Socket Head Setscrew	32	
69				
70	60062RS	Bearing	8	
71	60102RS	Bearing	8	
72	63052RS	Bearing	1	
73				
74	DW25131	Compression Spring	8	
75				
76	LFTC35A	Bearing	5	
77	PS843	Ø25 External Circlip	2	
78	RPC648.061001	Grease Nipple 45°	7	
79	RPH850.306210	Hydraulic Motor	5	
80				
81	SS040011/003	Steel Spacer	5	
82	SS035011/005	Steel Spacer	2	
83				
84	W0111	Ø55 Internal Circlip	4	
85	W0117	Ø45 External Circlip	5	
86	W0161	Ø80 Internal Circlip	9	
87	W0168	Ø62 Internal Circlip	1	
88				
89				
		<b>Hydraulic Components Consist Of:</b>		
90	11124	1/2"BSP Dowty Seal	18	
91	11295	1/2"BSP x 3/4"BSP M M Adaptor	4	
92				
93	12315	1/2"BSP M M Adaptor	14	
94				
95	41115	3/4"BSP M F Compact 90°Adaptor	1	
96				
97				
98				
99	60359	1/2"Hose Assembly (700mm)	1	
100	60431	1/2"Hose Assembly (450mm)	2	

**QUALITY MASTER SPARE PARTS****5.1d**

Machines from Serial No QM154

**5R Omega Separator (237mm centres)**

Assy No 67094

Item	Part No.	Description	Qty.	Remarks
101	60490	1/2"Hose Assembly (500mm)	1	
102	60566	1/2"Hose Assembly (500mm)	2	
103	60943	3/4"Hose Assembly (2650mm)	1	
104	60944	3/4"Hose Assembly (2150mm)	1	
105	60945	3/4"Hose Assembly (950mm)	1	
106	60946	3/4"Hose Assembly (750mm)	1	
107	60947	1/2"Hose Assembly (1100mm)	1	



5R Omega Separator (237mm centres)  
Assy No 67094

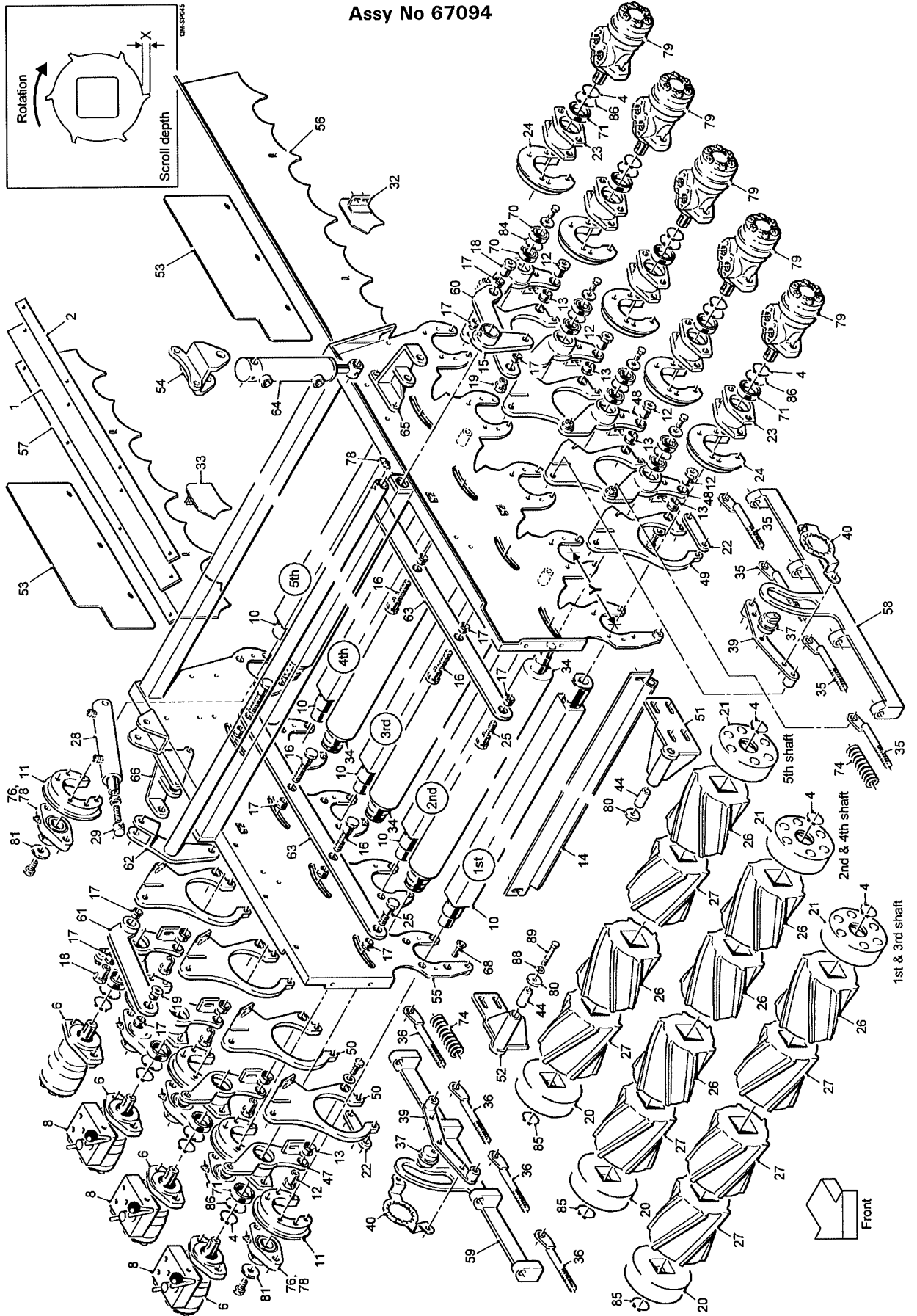

5.1a

QUALITY MASTER SPARE PARTS

5R Omega Separator (237mm centres)  
Assy No 67094

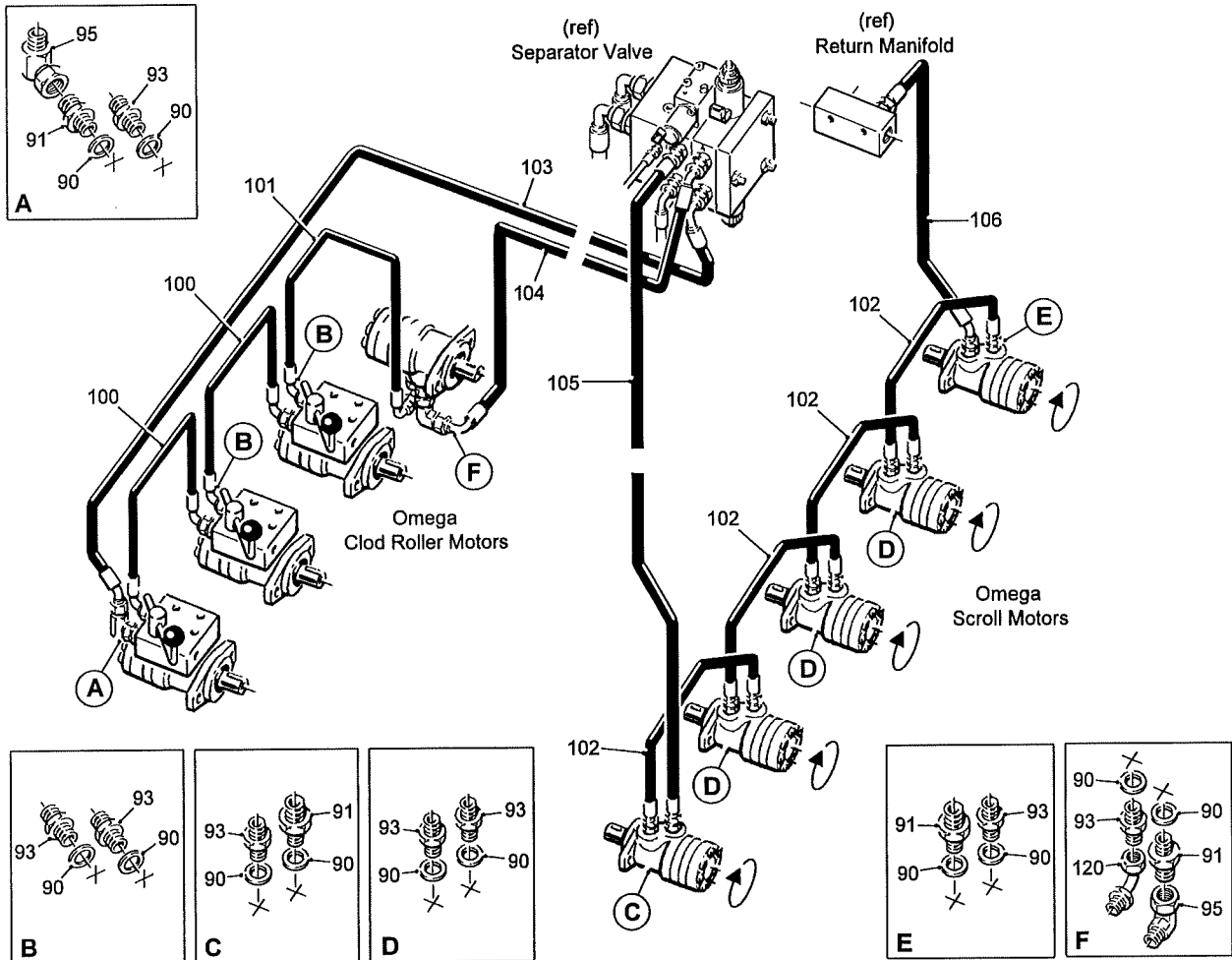

QM-SP046

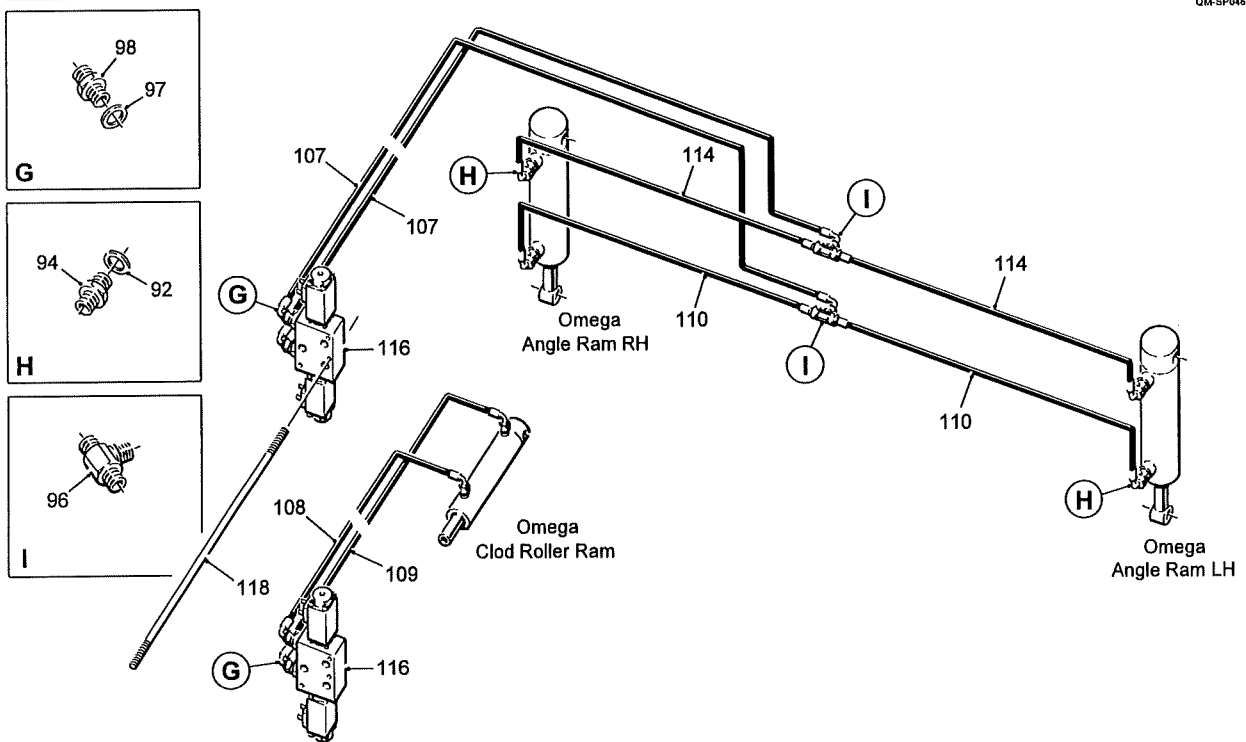



# QUALITY MASTER SPARE PARTS

5.1b

## 5R Omega Separator (237mm centres)

Assy No 67094

Item	Part No.	Description	Qty.	Remarks
1	67183	Rubber Deflector	2	
2	67184	Clamp Strip	2	
3				
4	33130/16	Ø50 External Circlip	14	
5				
6	44563	Hydraulic Motor	4	
7				
8	56112	Diverter Valve	3	
9				
10	59136A/1400	Scroll Shaft	5	
11	59143	Bearing Boss	5	
12	59162	Pivot Pin	8	
13	59163	Pivot Flange Bush	8	
14	59164/1400	Clod Roller Scraper	4	
15	59166	Clod Roller Lift Arm	1	
16	59174	Shoulder Bolt (long)	6	
17	59175	Pivot Flange Bush	14	
18	59176	Tapped Boss (long)	2	
19	59177	Tapped Boss (short)	2	
20	59348	Male End Cap (Ø45 bore)	5	
21	59348A	Male End Cap (Ø50 bore)	5	
22	59352	Carrier Plate Tie	8	
23	59529	Motor Mount	5	
24	59928	Bearing Boss	5	
25	59173	Shoulder Bolt (short)	2	
26	59934C	LH Cavity Scroll (x = 10mm)	20	LH Solid Scroll 59934S
	59936C	LH Cavity Scroll (x = 6mm)	20	LH Solid Scroll 59936S
27	59935C	RH Cavity Scroll (x = 10mm)	20	RH Solid Scroll 59935S
	59937C	RH Cavity Scroll (x = 6mm)	20	RH Solid Scroll 59937S
28	56679	Hydraulic Ram	1	
29	56690	Ram Eye	1	
30				
31				
32	62652	LH Deflector Plate (short)	4	
33	62653	RH Deflector Plate (short)	4	
34	62863/1400	Ø76 Rubber Clod Roller	4	
35	62903	LH Adjuster	4	
36	62904	RH Adjuster	4	
37	62908	Adjuster Boss	2	
38				
39	62913	Adjuster Plate	2	
40	62914	Indicator Plate	2	
41				
42				
43				
44	70090	Pivot Boss (with removal thread)	2	Prior to 2022 was 64747
45				
46				
47	64046	Clod Roller Motor Mount	4	
48	64047	Clod Roller Bearing Mount	4	

## 5.1c

## QUALITY MASTER SPARE PARTS

## 5R Omega Separator (237mm centres)

Assy No 67094

Item	Part No.	Description	Qty.	Remarks
49	64066	LH Carrier Plate	4	
50	64067	RH Carrier Plate	4	
51	67207	Pivot Bracket LH	1	
52	67208	Pivot Bracket RH	1	
53	67209	Infil Panel	2	
54	67203	Ram Mounting	2	
55	67005	5R Omega Frame	1	Y = 237mm
56	67006	Stainless Side Panel LH	1	
57	67007	Stainless Side Panel RH	1	
58	67008	Adjuster Strap LH	1	
59	67009	Adjuster Strap RH	1	
60	59921	Link LH	1	
61	59922	Link RH	1	
62	59165/1400	Clod Roller Lift Shaft	1	
63	67013	Link (237mm centres)	2	
64	67204	Hydraulic Ram	2	
65	67205	Ram Mounting LH	1	
66	67206	Ram Mounting RH	1	
67				
68	22016010/020	M10x20 CSK Socket Head Setscrew	40	
69				
70	60062RS	Bearing	8	
71	60102RS	Bearing	8	
72				
73				
74	DW25131	Compression Spring	8	
75				
76	LFTC35A	Bearing	5	
77				
78	RPC648.061001	Grease Nipple 45°	7	
79	RPH850.306210	Hydraulic Motor	5	
80	SS045013/006	Steel Spacer	2	
81	SS040011/003	Steel Spacer	5	
82				
83				
84	W0111	Ø55 Internal Circlip	4	
85	W0117	Ø45 External Circlip	5	
86	W0161	Ø80 Internal Circlip	9	
87				
88	22052012			
89	22012012/090	M12x90 Bolt	2	
		<b>Hydraulic Components Consist Of:</b>		
90	11124	1/2"BSP Dowty Seal	18	
91	11295	1/2"BSP x 3/4"BSP M M Adaptor	4	
92	11337	1/4"BSP Dowty Seal	4	
93	12315	1/2"BSP M M Adaptor	14	
94	12316	1/4"BSP M M Adaptor	4	
95	41115	3/4"BSP M F Compact 90° Adaptor	2	
96	27449	1/4"BSP M M M Tee	2	
97	27461	M18 Dowty Seal	4	
98	37599	M18x3/8"BSP M M Adaptor	4	
99				
100	60431	1/2"Hose Assembly (450mm)	2	

**QUALITY MASTER SPARE PARTS****5.1d****5R Omega Separator (237mm centres)****Assy No 67094**

<b>Item</b>	<b>Part No.</b>	<b>Description</b>	<b>Qty.</b>	<b>Remarks</b>
101	51538	1/2"Hose Assembly (650mm)	1	
102	60566	1/2"Hose Assembly (500mm)	4	
103	60943	3/4"Hose Assembly (2650mm)	1	
104	60944	3/4"Hose Assembly (2150mm)	1	
105	60945	3/4"Hose Assembly (950mm)	1	
106	60946	3/4"Hose Assembly (750mm)	1	
107	60966	1/4"Hose Assembly (5000mm)	2	
108	60967	1/4"Hose Assembly (4300mm)	1	
109	60968	1/4"Hose Assembly (4550mm)	1	
110	60201	1/4"Hose Assembly (1100mm)	2	
111				
112				
113				
114	13188	1/4"Hose Assembly (1000mm)	2	
115				
116	57085/3	Valve Section	2	
117				
118	RPS1233/1	Valve Bank Tie Rod (500mm)	3	
119				
120	26086	1/2"BSP M F Swept 90°Adaptor	1	



**Galaxy Star Separator**  
Assy No 67249

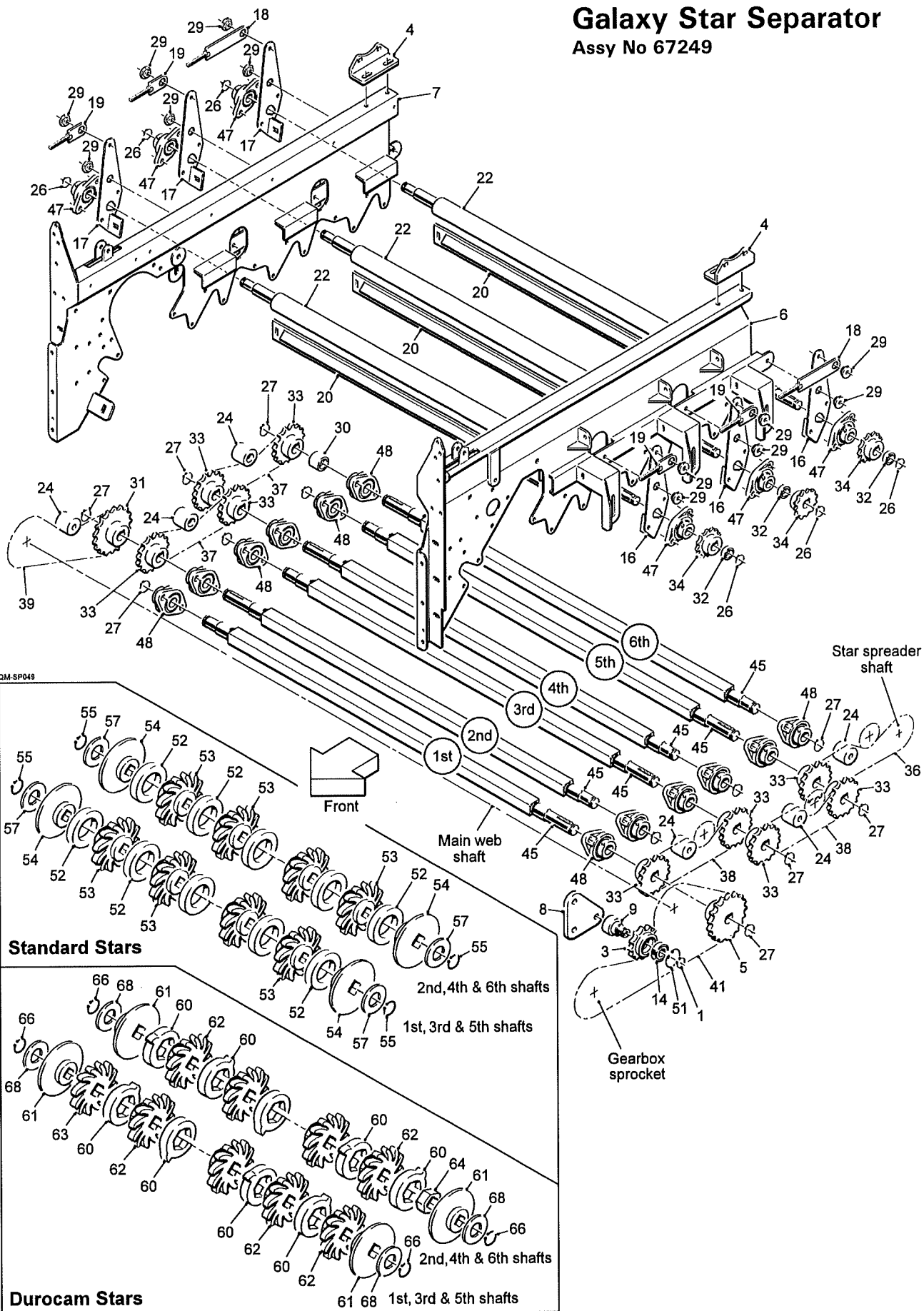

Galaxy Star Separator  
Assy No 67249

Panels for Galaxy to Spreader

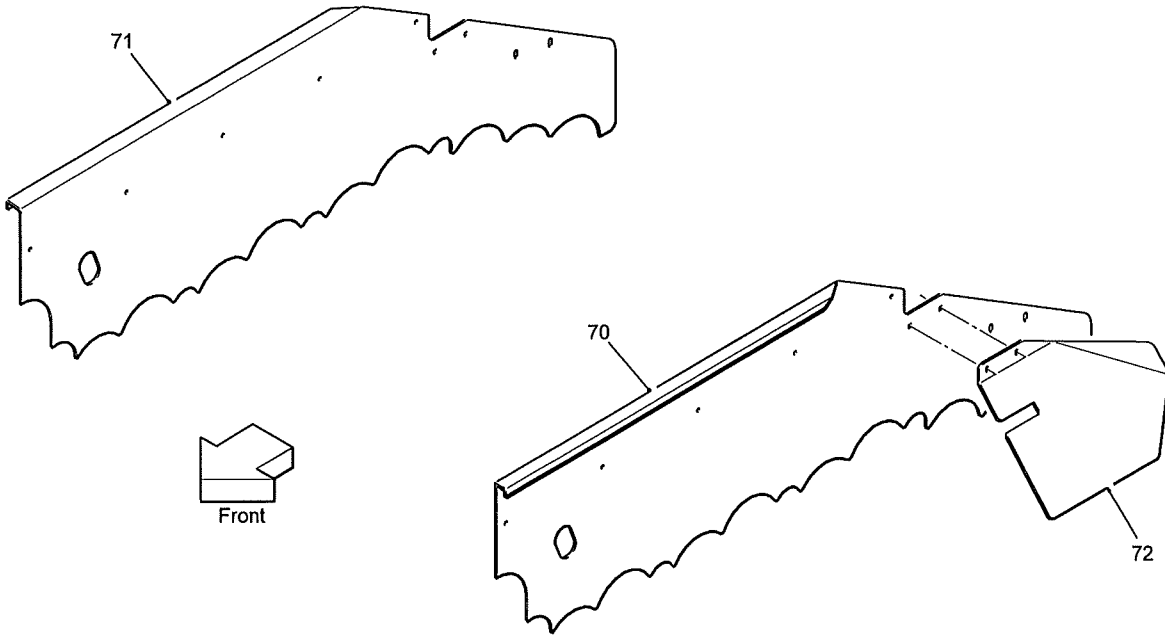

QM-SP050

Panels for Galaxy to Easi-Pic

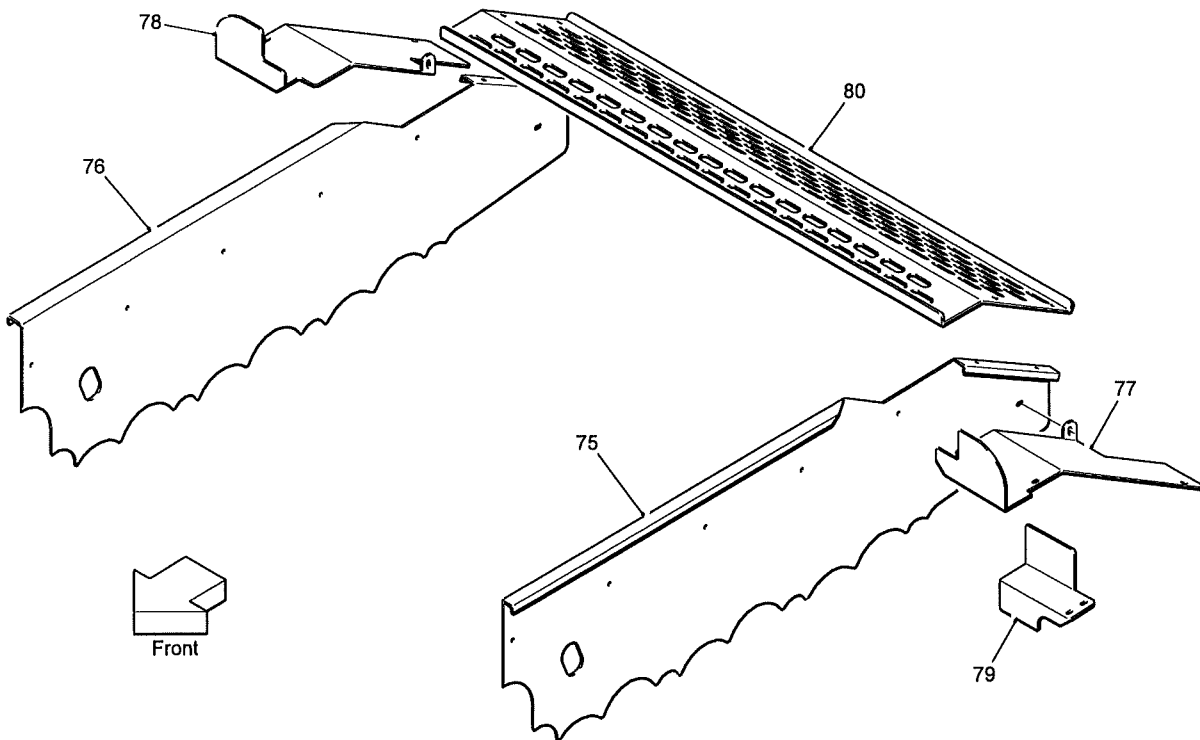

# QUALITY MASTER SPARE PARTS

5.2b

## Galaxy Star Separator

Assy No 67249

Item	Part No.	Description	Qty.	Remarks
1	12298	Ø20 External Circlip	1	
2				
3	67110	15T 1"Pitch Tensioner Sprocket	1	
4	67226	Mounting Bracket	2	
5	67228	24T 1"Pitch Sprocket	1	
6	67229	Mounting Plate LH	1	
7	67230	Mounting Plate RH	1	
8	67245	Sprocket Mounting Plate	1	
9	67246	Spindle	1	
10				
11				
12				
13				
14	62042RS	Bearing	1	
15				
16	RPA610.305695	Clod Roller Bracket LH	3	
17	RPA610.305696	Clod Roller Bracket RH	3	
18	RPA610.306308	Adjuster Long	2	
19	RPA610.306310	Adjuster Short	4	
20	RPA610.311101	Scraper	3	
21				
22	RPA610.305805	Ø48Round Clod Roller	3	Option
	RPA610.307092	Ø57Round Clod Roller	3	Option
	RPA610.305808	Square Clod Roller	3	Option
	RPM160.305810	Hexagonal Clod Roller	3	Option
23				
24	RPC700.304412	Nylon Chain Tensioner	6	
25				
26	RPF200.025200	Ø25 External Circlip	6	
27	RPF200.030200	Ø30 External Circlip	12	
28				
29	RPM106.304349	Top Hat Boss	12	
30	RPM176.300356	Spacer (35mm)	1	
31	RPM182.300347	24T 3/4"Pitch Sprocket	1	
32	RPM176.304612	Spacer (10mm)	3	
33	RPM182.300349	18T 3/4"Pitch Sprocket	9	
34	RPM182.303035	12T 3/4"Pitch Sprocket	3	
35				
36	RPT732.6200--	3/4"Pitch Drive Chain	1	
37	RPT732.620056	3/4"Pitch Drive Chain	2	
38	RPT732.620057	3/4"Pitch Drive Chain	2	
39	RPT732.620066	3/4"Pitch Drive Chain	1	
40				
41	-	1"Pitch Drive Chain	1	
42				
43				
44				
45	RPS1213	Starshaft (40x40 square)	6	
46				
47	SFT25	Bearing	6	
48	SFT30	Bearing	12	
49				
50				
51	W0113	Ø47 Internal Circlip	1	

## Galaxy Star Separator

Assy No 67249

Item	Part No.	Description	Qty.	Remarks
52	RPC700.303036	<b>Standard Stars Consists Of:</b> Spacer (for 14 finger star)	94	(for 2 starshafts)
	RPC700.305520	Spacer (for 18 finger star)	126	
53	RPC700.309598	14 Finger Star	92	
	RPC700.310893	18 Finger Star	124	
54	RPC700.310221	End Disc	4	
55	RPF200.035250	Ø35 External Circlip	4	
56				
57	SS070036/003	Steel Spacer	4	
		<hr/>		
		<b>Durocam Stars Consist Of:</b>		(for 2 starshafts)
60	RPC700.309550	Cam Ring	88	
61	RPC700.310221	End Disc	4	
62	RPC700.310541	14 Finger Durocam Star	88	
63	RPC700.311776	14 Finger Durocam Star Narrow	1	
64	RPC700.311777	Spacer	1	
65				
66	RPF200.035250	Ø35 External Circlip	4	
67				
68	SS070036/003	Steel Spacer	4	
		<hr/>		
		<b>Panels for Galaxy to Spreader</b> <b>Consist Of:</b>		
70	67251	Stainless Panel LH	1	
71	67252	Stainless Panel RH	1	
72	67261	Spreader Chain Guard	1	
		<hr/>		
		<b>Panels for Galaxy to Easi-Pic</b> <b>Consist Of:</b>		
75	67313	Stainless Panel LH	1	
76	67314	Stainless Panel RH	1	
77	67315	Infill Panel LH	1	
78	67316	Infill Panel RH	1	
79	67317	Infill Panel Bottom	1	
80	67318	Cover Panel Top	1	



5R Omega Separator (220mm centres)  
Assy No 67348

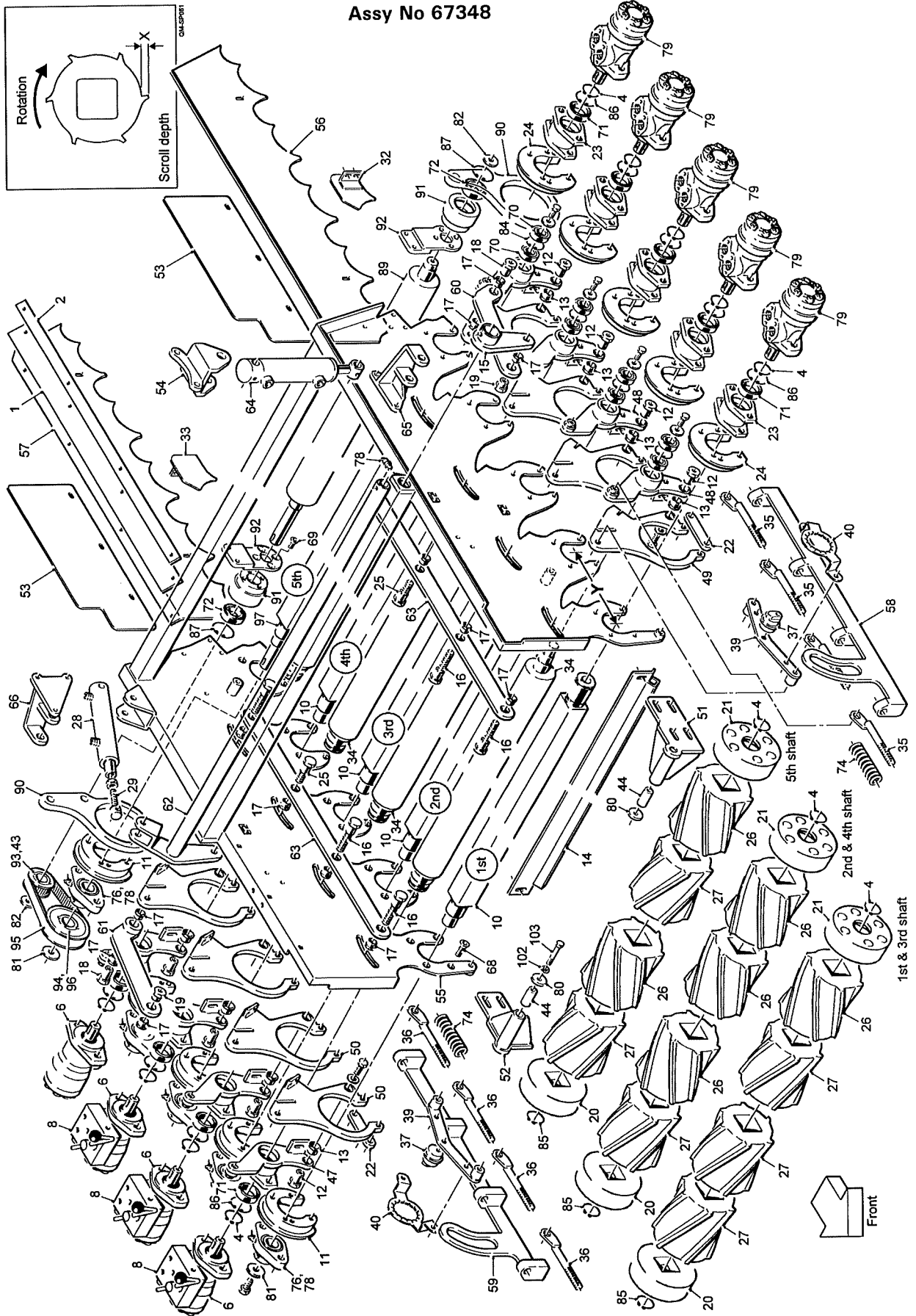

5R Omega Separator (220mm centres)  
 Assy No 67348

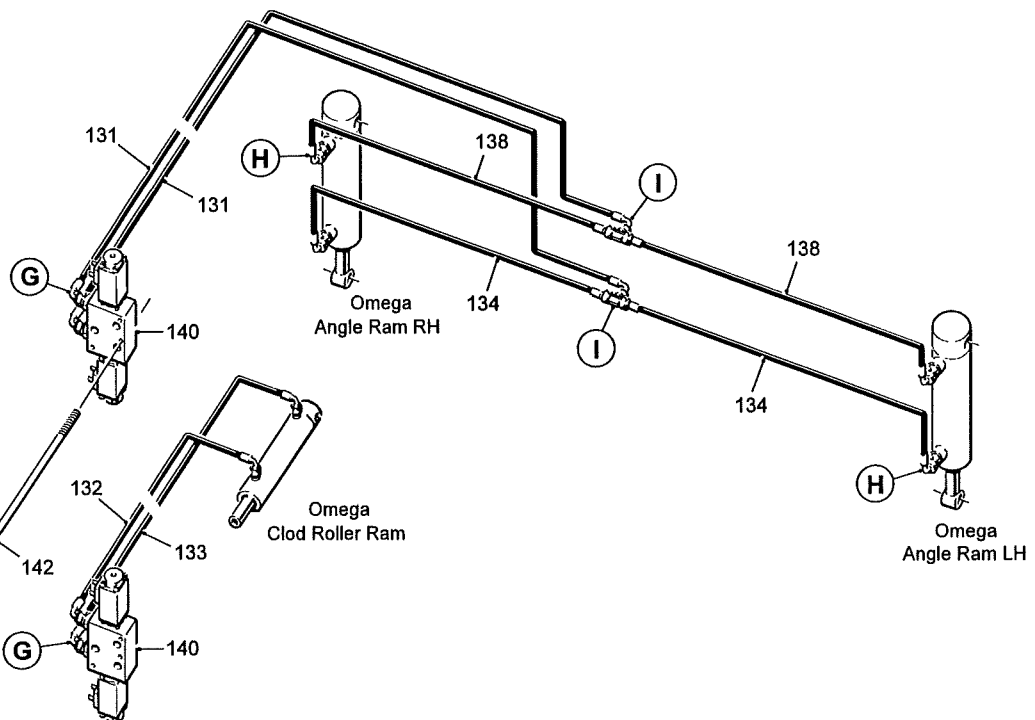
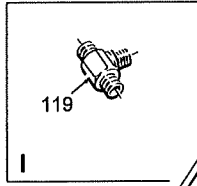
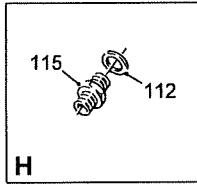
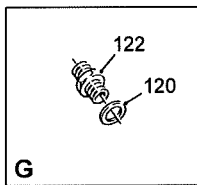
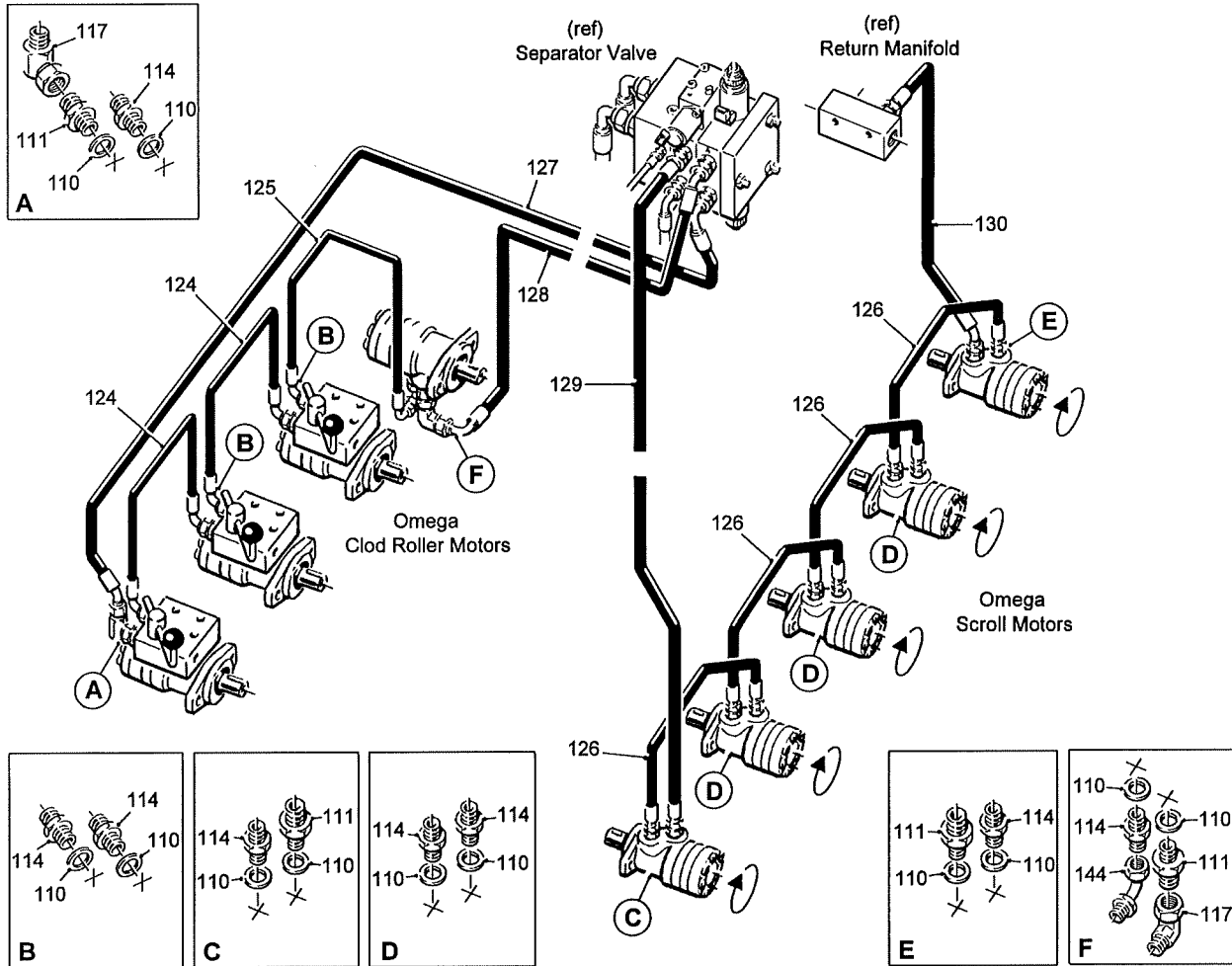

QM-SP062

# QUALITY MASTER SPARE PARTS

5.3b

## 5R Omega Separator (220mm centres)

Assy No 67348

Item	Part No.	Description	Qty.	Remarks
1	67358	Rubber Deflector	2	
2	67363	Clamp Strip	2	
3				
4	33130/16	Ø50 External Circlip	14	
5				
6	44563	Hydraulic Motor	4	
7				
8	56112	Diverter Valve	3	
9				
10	59136A/1400	Scroll Shaft	4	
11	59692	Bearing Boss (angled bearing)	5	
12	59162	Pivot Pin	8	
13	59163	Pivot Flange Bush	8	
14	59164/1400	Clod Roller Scraper	4	
15	59166	Clod Roller Lift Arm	1	
16	59174	Shoulder Bolt (long)	6	
17	59175	Pivot Flange Bush	14	
18	59176	Tapped Boss (long)	2	
19	59177	Tapped Boss (short)	2	
20	59348	Male End Cap (Ø45 bore)	5	
21	59348A	Male End Cap (Ø50 bore)	5	
22	59352	Carrier Plate Tie	8	
23	59529	Motor Mount	5	
24	59928	Bearing Boss	5	
25	59173	Shoulder Bolt (short)	2	
26	59934C	LH Cavity Scroll (x=10mm)	20	LH Solid Scroll 59934S
	59936C	LH Cavity Scroll (x=6mm)	20	LH Solid Scroll 59936S
27	59935C	RH Cavity Scroll (x=10mm)	20	RH Solid Scroll 59935S
	59937C	RH Cavity Scroll (x=6mm)	20	RH Solid Scroll 59937S
28	56679	Hydraulic Ram	1	
29	56690	Ram Eye	1	
30				
31				
32	62652	LH Deflector Plate (short)	4	
33	62653	RH Deflector Plate (short)	4	
34	62753/1400	Ø60 Stainless Clod Roller	4	
35	62903	LH Adjuster	4	
36	62904	RH Adjuster	4	
37	62908	Adjuster Boss	2	
38				
39	62913A	Adjuster Plate (220mm centres)	2	
40	62914	Indicator Plate	2	
41				
42				
43	64424	Taperlock Bush	1	
44	70090	Pivot Boss (with removal thread)	2	Prior to 2022 was 64747
45				
46				
47	64046	Clod Roller Motor Mount	4	
48	64047	Clod Roller Bearing Mount	4	

## 5.3c

## QUALITY MASTER SPARE PARTS

## 5R Omega Separator (220mm centres)

Assy No 67348

Item	Part No.	Description	Qty.	Remarks
49	64066	LH Carrier Plate	4	
50	64067	RH Carrier Plate	4	
51	67207	Pivot Bracket LH	1	
52	67208	Pivot Bracket RH	1	
53	67209	Infil Panel	2	
54	67203	Ram Mounting	2	
55	67347	5R Omega Frame	1	Y = 220mm
56	67361	Stainless Side Panel LH	1	
57	67362	Stainless Side Panel RH	1	
58	64197LH	Adjuster Strap LH (220mm centres)	1	
59	64197RH	Adjuster Strap RH (220mm centres)	1	
60	67359	Link LH	1	
61	67360	Link RH	1	
62	59165/1400	Clod Roller Lift Shaft	1	
63	59694	Link (220mm centres)	2	
64	67204	Hydraulic Ram	2	
65	67205	Ram Mounting LH	1	
66	67206	Ram Mounting RH	1	
67				
68	22016010/020	M10x20 CSK Socket Head Setscrew	40	
69	22016008/016	M8x16 CSK Socket Head Setscrew	8	
70	60062RS	Bearing	8	
71	60102RS	Bearing	8	
72	60052RS	Bearing	4	
73				
74	DW25131	Compression Spring	8	
75				
76	LFTC35A	Bearing	5	
77				
78	RPC648.061001	Grease Nipple 45°	7	
79	RPH850.306210	Hydraulic Motor	5	
80	SS045013/006	Steel Spacer	2	
81	SS040011/003	Steel Spacer	5	
82	SS030011/005	Steel Spacer	2	
83				
84	W0111	Ø55 Internal Circlip	4	
85	W0117	Ø45 External Circlip	5	
86	W0161	Ø80 Internal Circlip	9	
87	W0113	Ø47 Internal Circlip	2	
88				
89	67349	Ø73 Stainless Transfer Roller	1	
90	67350	Omega to Easi-pic Link	2	
91	67351	Bearing Housing	2	
92	67352	Roller Mounting Plate	2	
93	67353	34T Pulley	1	
94	67354	64T Pulley	1	
95	67355	Pulley Belt	1	
96	67356	Taperlock Bush	1	
97	67357/1400	Rear Scroll Shaft	1	
98				
99				
100				
101				
102	22052012	M12 Spring Washer	2	
103	22012012/090	M12x90 Bolt	2	

# QUALITY MASTER SPARE PARTS

5.3d

## 5R Omega Separator (220mm centres)

Assy No 67348

Item	Part No.	Description	Qty.	Remarks
		<b>Hydraulic Components Consist Of:</b>		
110	11124	1/2" BSP Dowty Seal	18	
111	11295	1/2" BSP x 3/4" BSP M M Adaptor	4	
112	11337	1/4" BSP Dowty Seal	4	
113				
114	12315	1/2" BSP M M Adaptor	14	
115	12316	1/4" BSP M M Adaptor	4	
116				
117	41115	3/4" BSP M F Compact 90° Adaptor	2	
118				
119	27449	1/4" BSP M M M Tee	2	
120	27461	M18 Dowty Seal	4	
121				
122	37599	M18x3/8" BSP M M Adaptor	4	
123				
124	60431	1/2" Hose Assembly (450mm)	2	
125	51538	1/2" Hose Assembly (650mm)	1	
126	60566	1/2" Hose Assembly (500mm)	4	
127	60943	3/4" Hose Assembly (2650mm)	1	
128	60944	3/4" Hose Assembly (2150mm)	1	
129	60945	3/4" Hose Assembly (950mm)	1	
130	60946	3/4" Hose Assembly (750mm)	1	
131	60966	1/4" Hose Assembly (5000mm)	2	
132	60967	1/4" Hose Assembly (4300mm)	1	
133	60968	1/4" Hose Assembly (4550mm)	1	
134	60201	1/4" Hose Assembly (1100mm)	2	
135				
136				
137				
138	13188	1/4" Hose Assembly (1000mm)	2	
139				
140	57085/3	Valve Section	2	
141				
142	RPS1233/1	Valve Bank Tie Rod (500mm)	3	
143				
144	26086	1/2" BSP M F Swept 90° Adaptor	1	



Machines from Serial No QM154

**Star Spreader Assembly (for Omega)**  
Assy No 67105

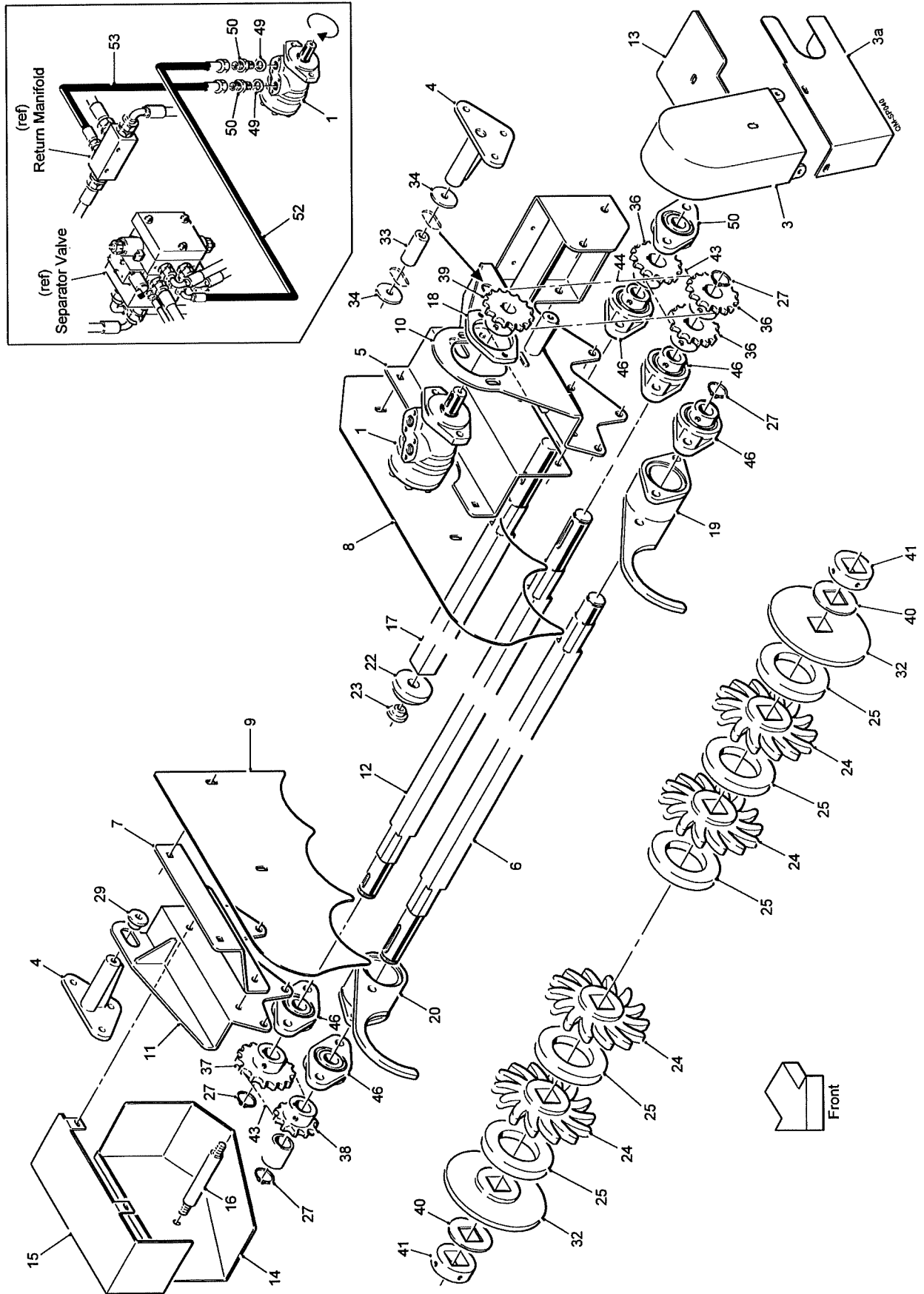

## 6.1a

## QUALITY MASTER SPARE PARTS

Machines from Serial No QM154

## Star Spreader Assembly (for Omega)

Assy No 67105

Item	Part No.	Description	Qty.	Remarks
1	44563	Hydraulic Motor	1	
2				
3	67037	Chain Guard Top	1	
3a	67037a	Chain Guard Bottom	1	
4	67040	Mounting Bracket	2	
5	67051	Mounting LH	1	
6	67053	1st Star Shaft	1	
7	67054	Mounting RH	1	
8	67055	Stainless Panel LH	1	
9	67056	Stainless Panel RH	1	
10	67065	Bearing Mounting LH	1	
11	67066	Bearing Mounting RH	1	
12	67080	2nd Starshaft	1	
13	67125	Chain Guard LH Top	1	
14	67126	Chain Guard RH	1	
15	67127	Chain Guard RH Top	1	
16	67128	Guard Bolt	1	
17	67133	3rd Star Shaft	1	
18	65134	Motor Clamp Plate	1	
19	67135	Link LH	1	
20	67136	Link RH	1	
21				
22	RPC700.300666	Plastic End Cap	1	
23	RPC700.300667	Plastic Spigot Washer	1	
24	RPC700.302445	14 Finger Star (blue)	113	
25	RPC700.303036	Star Spacer	115	
26				
27	RPF200.030200	Ø30 External Circlip	4	
28				
29	57725	Top Hat Spacer	1	
30				
31				
32	RPGM088.00208	End Disc	5	
33	SS025013/073	Steel Spacer	1	
34	SS050013/005	Steel Spacer	2	
35				
36	RPM182.300348	15T 3/4"Pitch Sprocket	3	
37	RPM182.300349	18T 3/4"Pitch Sprocket	1	
38	RPM182.300354	12T 3/4"Pitch Sprocket	1	
39	RPM182.306371	15T 3/4"Pitch Sprocket	1	
40	RPM226.300468	Retaining Washer	5	
41	RPM226.311778	Square Collar	5	
42				
43	RPT732.620030	3/4"Pitch Drive Chain	2	
44	RPT732.*****	3/4"Pitch Drive Chain	1	
45				
46	SFT30	Bearing	6	
47				
48				
		<b>Hydraulic Components Consist Of:</b>		
49	11124	1/2"BSP Dowty Seal	2	
50	12315	1/2"BSP M M Adaptor	2	
51				
52	60251	1/2"Hose Assembly (1500mm)	1	
53	60566	1/2"Hose Assembly (500mm)	1	



Machines from Serial No QM154

Discharge Elevator (lower section)  
Assy No RPS533

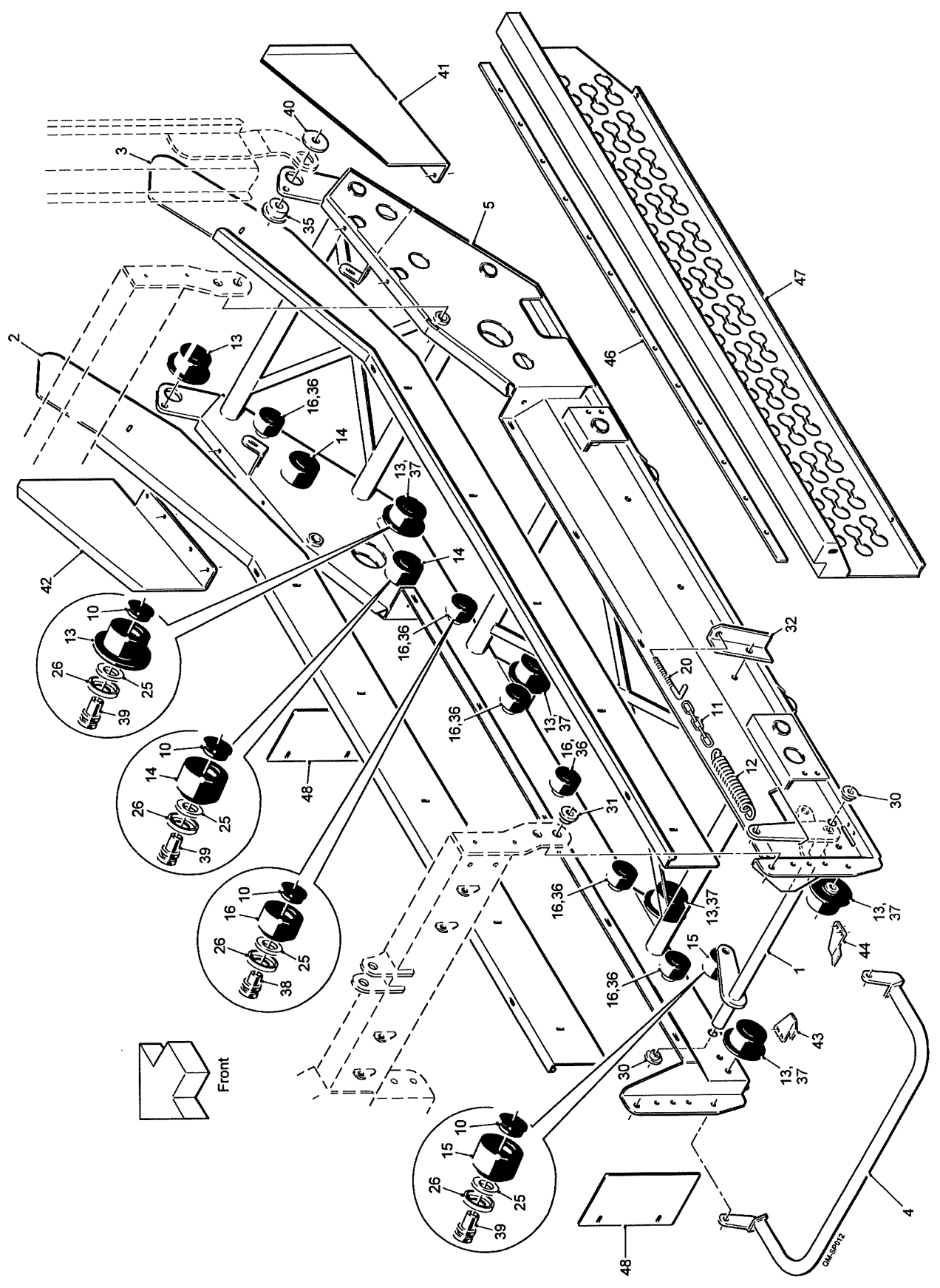

## 6.2a

## QUALITY MASTER SPARE PARTS

Machines from Serial No QM154

## Discharge Elevator (lower section)

Assy No RPS533

Item	Part No.	Description	Qty.	Remarks
1	RPA610.305930	Web Tensioner Frame	1	
2	RPA610.305942	Side Panel LH	1	
3	RPA610.305943	Side Panel RH	1	Standard
	RPA610.306799	Side Panel RH	1	Used with Easi-pic
4	RPA610.305947	Guard Rail	1	
5	RPA610.305948	Elevator Lower Section	1	
6				
7				
8				
9				
10	RPC620.303070	Cap	28	
11	RPC622.306531	Chain	1	
12	RPC676.304679	Tension Spring	1	
13	RPC700.300146	Ø95 Flanged Roller c/w Bearings	10	
14	RPC700.300147	Ø95 Plain Roller c/w Bearings	4	
15	RPC700.300148	Ø75 Plain Roller c/w Bearings	2	
16	RPC700.300227	Ø75 Plain Roller c/w Bearing	12	
17				
18				
19				
20	RPF128.110130	M10 Hook Bolt	1	
21				
22				
23				
24				
25	RPGM070.00446	Felt Seal	28	
26	RPGM089.00565	Roller Shield	28	
27				
28				
29				
30	RPM106.304349	Pivot Boss	2	
31	RPM106.306628	Mounting Arm Boss	1	
32	RPM108.306882	Spring Bracket	1	
33				
34				
35	RPM148.306012	Elevator Pivot Boss	2	
36	RPM176.306318	Spacer (20mm)	12	
37	RPM176.306319	Spacer (10mm)	8	
38	RPM180.300308	Roller Spindle	12	
39	RPM180.303071	Roller Spindle	16	
40	RPM196.305534	Elevator Pivot Washer	2	
41	RPM216.306992	Guard Panel	1	
42	RPM216.306993	Guard Panel	1	
43	RPM225.305859	Scraper LH	1	
44	RPM225.305860	Scraper RH	1	
45				
46	67140	Clamp Plate	1	Not used with Easi-pic
47	67143	Rear Panel	1	Not used with Easi-pic
48	67170	Infill Panel	2	

Machines from Serial No QM154

Discharge Elevator (centre section)

Assy No RPS534

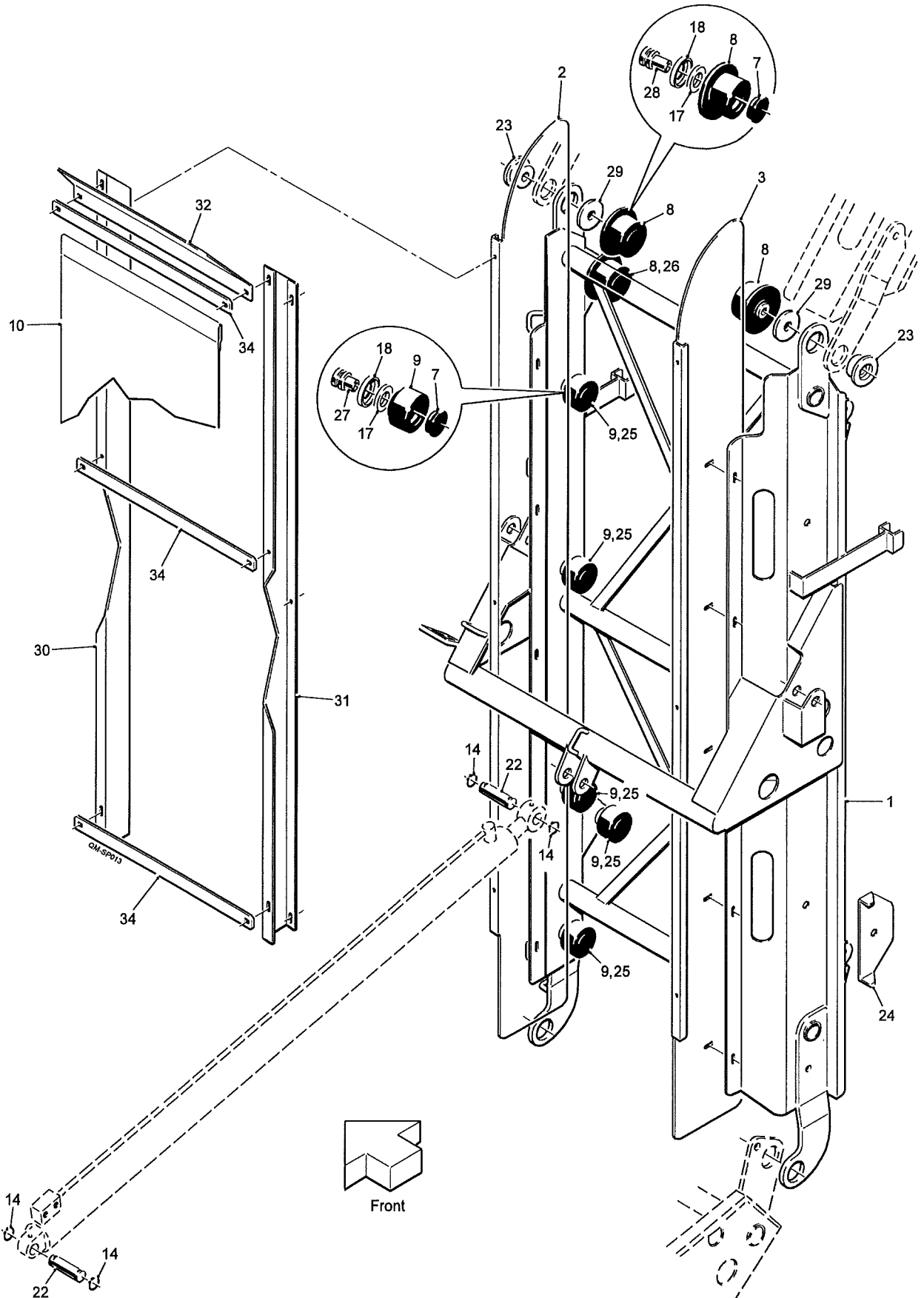

## 6.3a

## QUALITY MASTER SPARE PARTS

Machines from Serial No QM154

## Discharge Elevator (centre section)

Assy No RPS534

Item	Part No.	Description	Qty.	Remarks
1	RPA610.305949	Elevator Centre Section	1	
2	RPA610.307774	Side Panel LH	1	
3	RPA610.307775	Side Panel RH	1	
4				
5				
6				
7	RPC620.303070	Cap	14	
8	RPC700.300146	Ø95 Flanged Roller c/w Bearings	4	
9	RPC700.300227	Ø75 Plain Roller c/w Bearings	10	
10	RPC720.306079	Centre Cover	1	
11				
12				
13				
14	RPF200.025200	Ø25 External Circlip	4	
15				
16				
17	RPGM070.00446	Felt Seal	14	
18	RPGM089.00565	Roller Shield	14	
19				
20				
21				
22	RPM146.306262	Ram Pivot Pin	2	
23	RPM148.306012	Elevator Pivot Boss	2	
24	RPM170.306883	Shield	2	
25	RPM176.306318	Spacer (20mm)	10	
26	RPM176.306319	Spacer (10mm)	2	
27	RPM180.300308	Roller Spindle	10	
28	RPM180.303071	Roller Spindle	4	
29	RPM196.305534	Elevator Pivot Washer	2	
30	RPM224.307194	Extension Panel LH	1	
31	RPM224.307195	Extension Panel RH	1	
32	RPM224.307196	Baffle Panel	1	
33				
34	RPM256.306157	Mounting Strip	3	

Machines from Serial No QM154

**Discharge Elevator (upper section)**  
Assy No RPS532

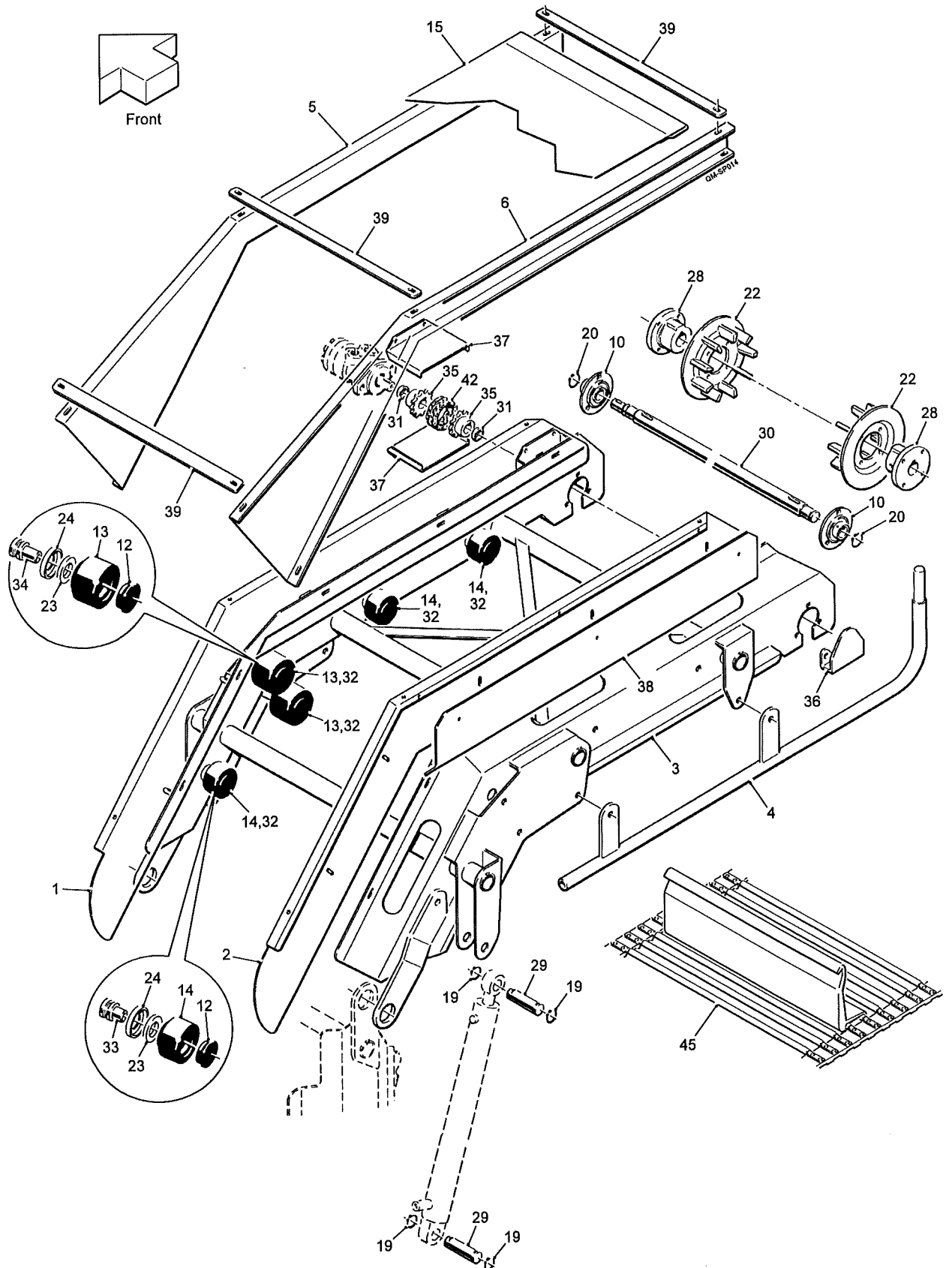

## 6.4a

## QUALITY MASTER SPARE PARTS

Machines from Serial No QM154

## Discharge Elevator (upper section)

Assy No RPS532

Item	Part No.	Description	Qty.	Remarks
1	RPA610.305944	Side Panel LH	1	
2	RPA610.305945	Side Panel RH	1	
3	RPA610.305950	Elevator Swan Neck Section	1	
4	RPA610.305953	Guard Rail	2	
5	RPA610.307197	Extension Panel LH	1	
6	RPA610.307198	Extension Panel RH	1	
7				
8				
9				
10	RPB210.022062	Bearing	2	
11				
12	RPC620.303070	Cap	10	
13	RPC700.300147	Ø95 Plain Roller c/w Bearings	4	
14	RPC700.300227	Ø75 Plain Roller c/w Bearings	6	
15	RPC720.306080	Upper Cover	1	
16				
17				
18				
19	RPF200.025200	Ø25 External Circlip	8	
20	RPF200.030200	Ø30 External Circlip	2	
21				
22	RPGM006.00244	Finger Roller (35mm pitch)	2	
23	RPGM070.00446	Felt Seal	10	
24	RPGM089.00565	Roller Shield	10	
25				
26				
27				
28	RPM134.302235	Finger Roller Hub	2	
29	RPM146.306262	Ram Pivot Pin	4	
30	RPM162.305956	Drive Shaft	1	
31	RPM176.303034	Spacer (5mm)	2	
32	RPM176.306318	Spacer (20mm)	14	
33	RPM180.300308	Roller Spindle	6	
34	RPM180.303071	Roller Spindle	4	
35	RPM182.303035	12T 3/4"Pitch Sprocket	2	
36	RPM206.303069	Bearing Cover	1	
37	RPM216.306327	Guard	2	
38	RPM224.306330	Decal Panel	2	
39	RPM256.306157	Mounting Strip	3	
40				
41				
42	RPT738.600012	3/4"Pitch Duplex Chain	1	
43				
44				
45	RPW300.306329	Elevator Web (35mm pitch)	1	

Machines from Serial No QM154

Windrow Conveyor  
Assy No 67089

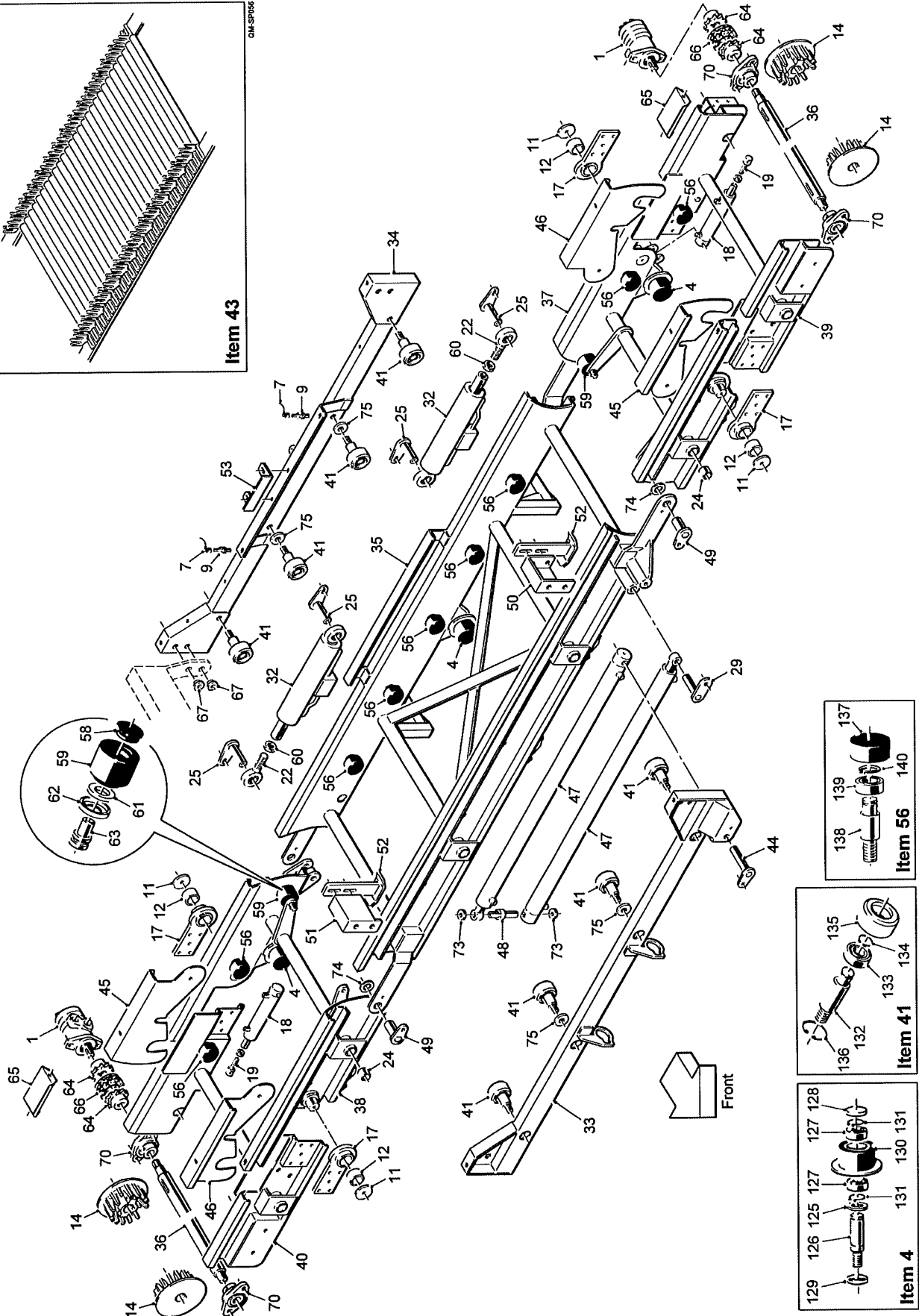
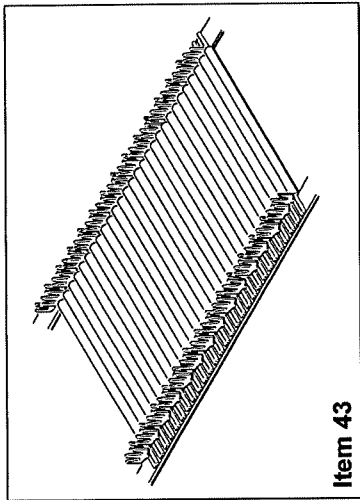

# 6.5a

# QUALITY MASTER SPARE PARTS

Machines from Serial No QM154

## Windrow Conveyor Assy No 67089

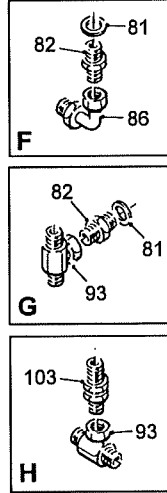
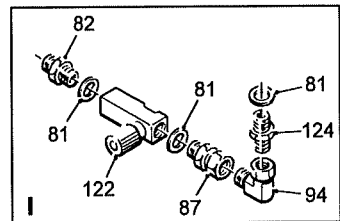
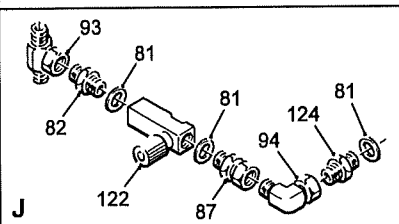
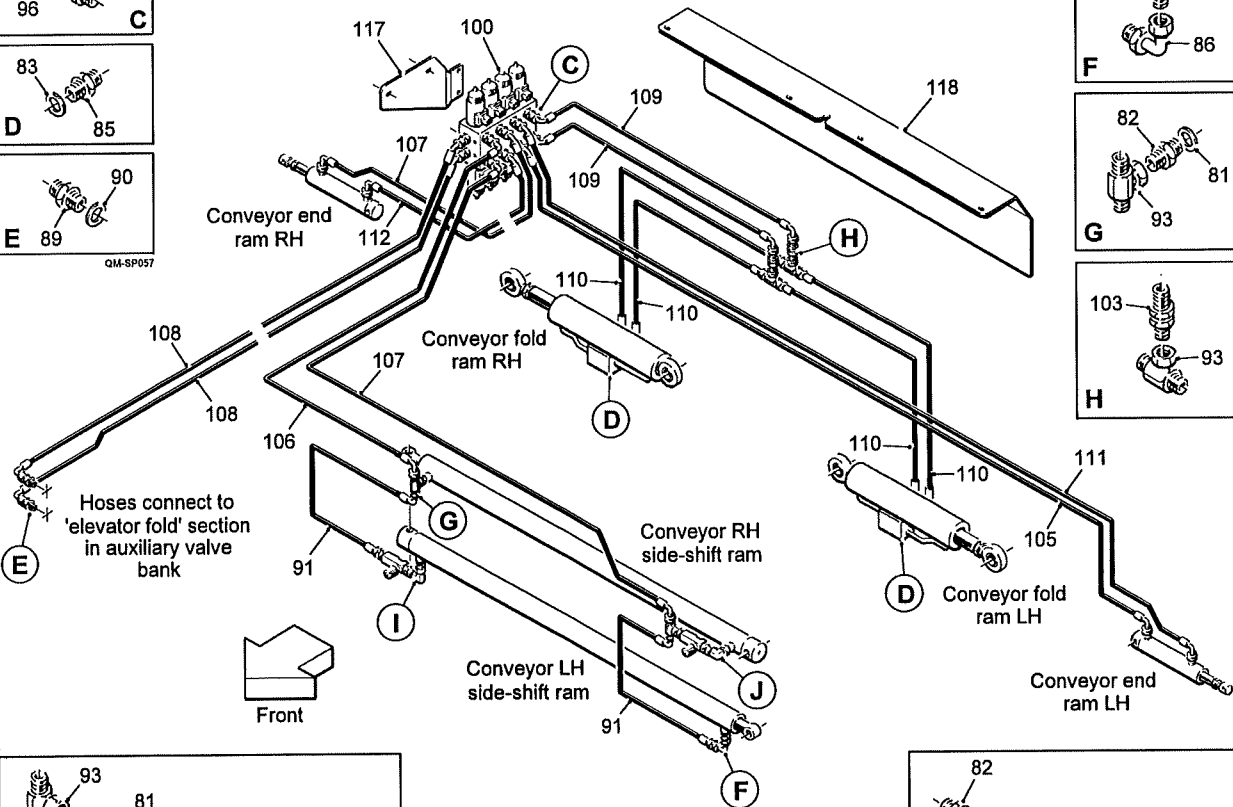
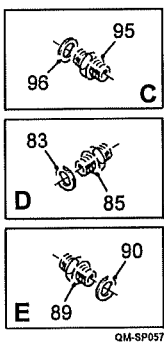
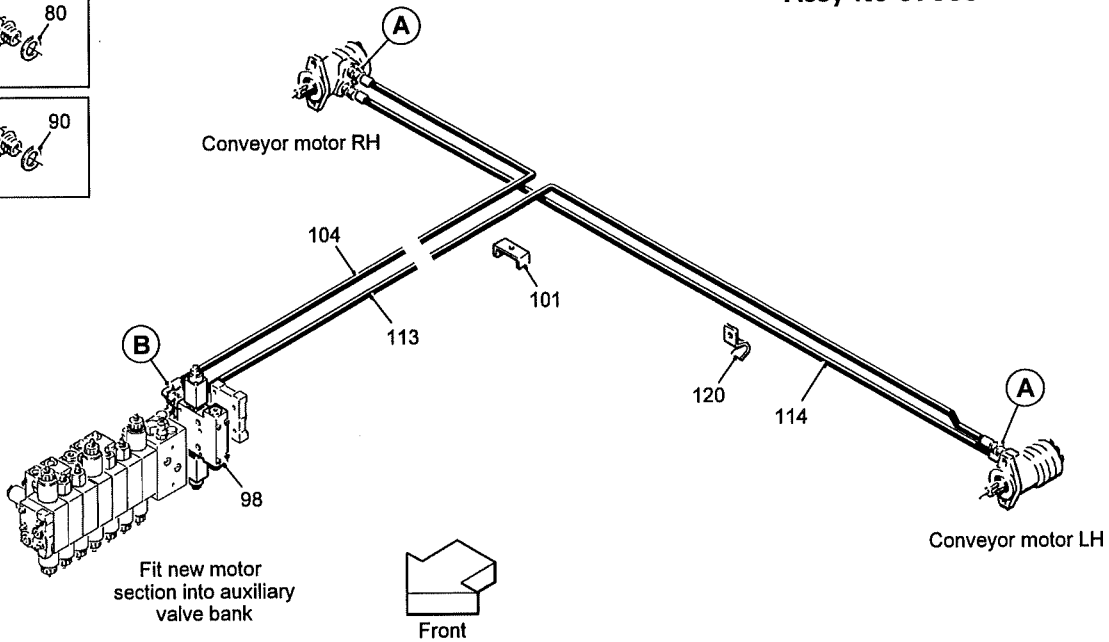
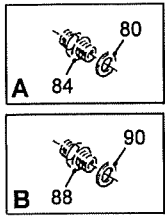



**QUALITY MASTER SPARE PARTS****6.5b**

Machines from Serial No QM154

**Windrow Conveyor****Assy No 67089**

Item	Part No.	Description	Qty.	Remarks
1	11201	Hydraulic Motor	2	
2				
3				
4	12506	Ø90 Flanged Roller Assembly	6	(see list at end)
5				
6				
7	32037/4	Sensor Cable 90°(10m)	2	
8				
9	41504	Sensor	2	
10				
11	46196	Pivot Retainer	4	
12	46379	Nylon Bearing	4	
13				
14	47079/40	40mm Pitch Web Sprocket	4	
15				
16				
17	56591	Pivot Plate	4	
18	56679A	Hydraulic Ram	2	
19	56690	Ram Eye	2	
20				
21				
22	57035	Rod End Male	2	
23				
24	61418	Ollite Bush	4	
25	61525	Ram Pin (69mm)	4	
26				
27				
28				
29	62154A	Ram Pin (110mm)	2	
30				
31				
32	67043	Hydraulic Ram	2	
33	67067	Mounting Beam Front	1	
34	67068	Mounting Beam Rear	1	
35	67069	Conveyor Centre Section	1	
36	67070	Drive Shaft	2	
37	67071	Conveyor 1st Section LH	1	
38	67072	Conveyor 1st Section RH	1	
39	67073	Conveyor End Section LH	1	
40	67074	Conveyor End Section RH	1	
41	67087	Ø70 Plain Roller Assembly	8	(see list at end)
42				
43	67100	40mm Pitch Web Assembly	1	
44	67101	Ram Pin (136mm)	1	
45	67164	Infill Panel	2	
46	67165	Infill Panel	2	
47	67166	Hydraulic Ram	2	
48	67167	Ram Joining Pin	1	
49	67168	Hinge Pin	4	
50	67171	Web Support Bracket LH	1	
51	67172	Web Support Bracket RH	1	
52	67173	Web Support Bar	2	
53	67187	Panel Rest	1	
54				
55				

## 6.5c

## QUALITY MASTER SPARE PARTS

Machines from Serial No QM154

## Windrow Conveyor

Assy No 67089

Item	Part No.	Description	Qty.	Remarks
56	0000301600	Ø66 Roller Assembly	18	(see list at end)
57				
58	RPC620.303070	Cap	4	
59	RPC700.300148	Ø75 Plain Roller cw/w Bearings	4	
60	RPF174.524000	M24 Lock Nut	2	
61	RPGM070.00446	Felt Seal	4	
62	RPGM089.00565	Roller Shield	4	
63	RPM180.303071	Roller Spindle	4	
64	RPM182.303035	12T 3/4"Pitch Sprocket	4	
65	RPM206.304847	Cover	2	
66	RPT738.600012	3/4"Pitch Duplex Chain	2	
67	RPM106.306628	Mounting Arm Boss	2	
68				
69				
70	SFT30	Bearing	4	
71				
72				
73	SS040011/005	Steel Spacer	2	
74	SS045036/003	Steel Spacer	4	
75	SS050017/005	Steel Spacer	4	
		<b>Hydraulic Components Consist Of:</b>		
80	11124	1/2"BSP Dowty Seal	4	
81	11125	3/8"BSP Dowty Seal	8	
82	11336	1/4"BSPx3/8"BSP M M Adaptor	4	
83	11337	1/4"BSP Dowty Seal	4	
84	12315	1/2"BSP M M Adaptor	4	
85	12316	1/4"BSP M M Adaptor	4	
86	12378	1/4"BSP M F Swept 90°Adaptor	2	
87	10128	3/8"BSP M F Swivel Adaptor	2	
88	27459	M18x1/2"BSP M M Adaptor	2	
89	27460	M18x1/4"BSP M M Adaptor	2	
90	27461	M18 Dowty Seal	4	
91	32890	1/4"Hose Assembly (1500mm)	2	
92				
93	37199	1/4"BSP M M F Tee	4	
94	42343	3/8"BSP M F Compact 90°Adaptor	2	
95	44207	M14x1/4"BSP M M Adaptor	10	
96	44208	M14 Dowty Seal	4	
97				
98	57444	Windrow Motor Section	1	
99				
100	59104	Slave Valve	1	
101	59295	Pipe Clamp	1	
102				
103	60483	1/4"BSP Bulkhead Adaptor	2	
104	60715	1/2"Hose Assembly (7500mm)	1	
105	60973	1/4"Hose Assembly (4500mm)	1	
106	60934	1/4"Hose Assembly (1650mm)	1	
107	60935	1/4"Hose Assembly (3350mm)	2	
108	60936	1/4"Hose Assembly (4100mm)	2	
109	60937	1/4"Hose Assembly (1350mm)	2	
110	60938	1/4"Hose Assembly (2550mm)	4	

# QUALITY MASTER SPARE PARTS

6.5d

Machines from Serial No QM154

Windrow Conveyor

Assy No 67089

Item	Part No.	Description	Qty.	Remarks
111	60939	1/4"Hose Assembly (4750mm)	1	
112	60940	1/4"Hose Assembly (3100mm)	1	
113	60941	1/2"Hose Assembly (8700mm)	1	
114	60942	1/2"Hose Assembly (5250mm)	1	
115				
116				
117	67147	Valve Mounting Plate	1	
118	67163	Hose Shield	1	
119				
120	RPC626.311691	Hose Clamp	1	
121				
122	KA17102	3/8"BSP Adjustable Restrictor	2	
123				
124	UC31A	3/8"BSP M M Adaptor	2	
	<b>12506</b>	<b>Roller Assembly Consists Of:</b>		
125	0000300504	Felt seal	1	
126	11265	Roller Spindle	1	
127	6005RS	Bearing	2	
128	PH407	Seal	1	
129	PH408	Seal	1	
130	PH51AR	Flanged Roller	1	
131	PS843	External Circlip	2	
	<b>67087</b>	<b>Roller Assembly Consists Of:</b>		
132	67086	Roller Spindle	1	
133	63042RS	Bearing	1	
134	RPF200.020175	Ø20 External Circlip	1	
135	RPM156.303068	Plain Steel Roller	1	
136	W0167	Ø52 Internal Circlip	1	
	<b>0000301600</b>	<b>Roller Assembly Consists Of:</b>		
137	0000301601	Plain Roller	1	
138	0000301602	Roller Spindle	1	
139	6204RS	Bearing	1	
140	12298	External Circlip	1	



Machines from Serial No QM154

**Star Spreader Assembly (for galaxy)**

Assy No 67105A

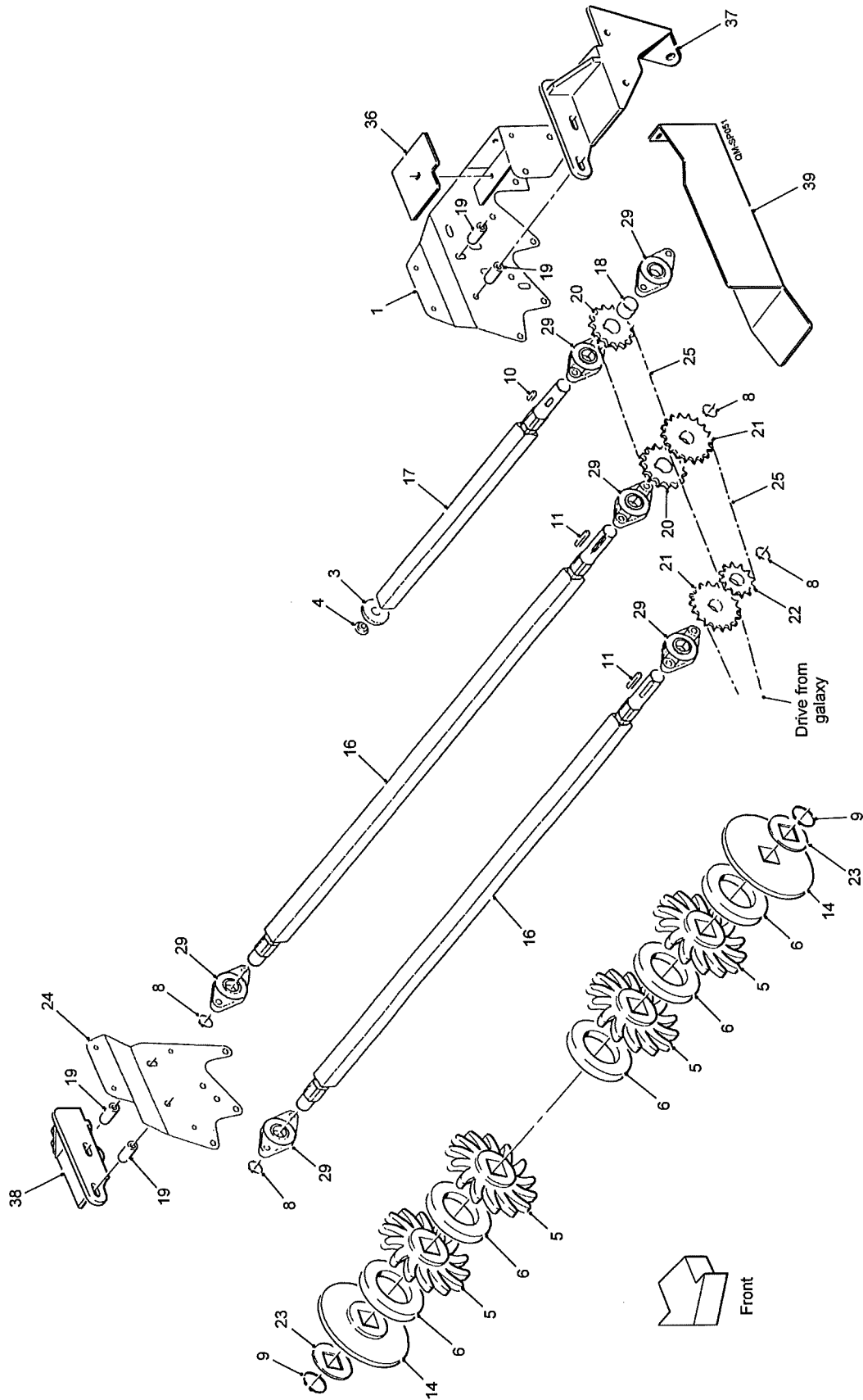

## 6.6a

## QUALITY MASTER SPARE PARTS

Machines from Serial No QM154

## Star Spreader Assembly (for galaxy)

Assy No 67105A

Item	Part No.	Description	Qty.	Remarks
1	RPA610.305690	Side Plate LH	1	
2				
3	RPC700.300666	Plastic End Cap	1	
4	RPC700.300667	Plastic Spigot Washer	1	
5	RPC700.302445	14 Finger Star (blue)	113	
6	RPC700.303036	Star Spacer	115	
7				
8	RPF200.030200	Ø30 External Circlip	5	
9	RPF200.035250	Ø35 External Circlip	5	
10	RPF210.088025	Key Plain (8x8x25)	1	
11	RPF210.088060	Key Plain (8x8x60)	2	
12				
13				
14	RPGM088.00208	End Disc	5	
15				
16	RPM166.305529	Star Shaft	2	
17	RPM166.305530	Star Shaft	1	
18	RPM176.304624	Spacer (35x31x50 lg)	1	
19	RPM176.306756	Spacer (40mm)	4	
20	RPM182.300348	15T 3/4" Pitch Sprocket	2	
21	RPM182.300349	18T 3/4" Pitch Sprocket	2	
22	RPM182.300354	12T 3/4" Pitch Sprocket	1	
23	RPM226.300468	Retaining Washer	5	
24	RPM242.305688	Side Plate RH	1	
25	RPT732.620030	3/4" Pitch Drive Chain	2	
26				
27				
28				
29	SFT30	Bearing	6	
30				
31				
32				
33				
34				
35				
36	67125	Chain Guard Top	1	
37	67231	Spreader Mount LH	1	
38	67232	Spreader Mount RH	1	
39	67257	Chain Guard Bottom	1	

Machines from Serial No QM154

**PTO & Main Drives**  
Assy No 67121

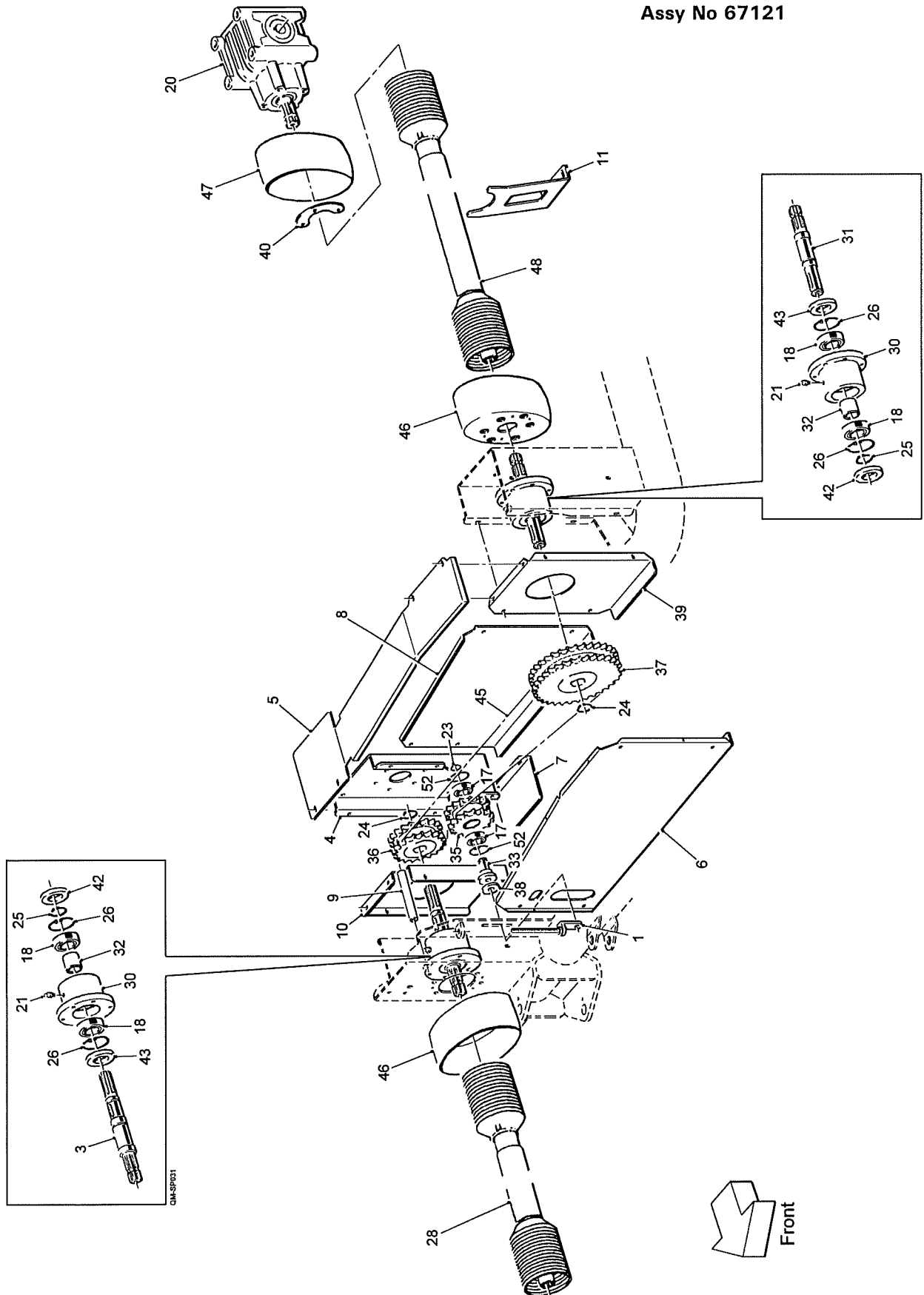

## 7.1a

## QUALITY MASTER SPARE PARTS

Machines from Serial No QM154

## PTO &amp; Main Drives

Assy No 67121

Item	Part No.	Description	Qty.	Remarks
1	61370	Jockey Adjuster	1	
2				
3	67077	Input Shaft	1	
4	67081	Front Gearbox/Pump Mounting Plate	1	
5	67082	Chain Guard Top	1	
6	67083	Chain Guard Front	1	
7	67084	Infill Panel Bottom	1	
8	67091	Chain Guard Rear	1	
9	67092	Tie Bar	1	
10	67107	Chain Guard Infill RH	1	
11	67185	PTO Guard Support	1	
12				
13				
14				
15				
16				
17	62052RS	Bearing	2	
18	6209	Bearing	4	
19				
20	RPC647.306372	Gearbox Assembly	1	
21	RPC648.081250	M8 Grease Nipple Straight	2	
22				
23	RPF200.025200	Ø25 External Circlip	1	
24	RPF200.040250	Ø40 External Circlip	2	
25	RPF200.045250	Ø45 External Circlip	2	
26	RPF202.085300	Ø85 Internal Circlip	4	
27				
28	RPGMRPB95.01223	PTO Drive Coupling c/w Slip Clutch	1	
29				
30	RPM132.302579	Bearing Housing	2	
31	RPM164.305746	Output Shaft	1	
32	RPM176.302586	Spacer	2	
33	RPM178.302612	Spigot	1	
34				
35	RPM182.302608	15T 1"Pitch Double Jockey Sprocket	1	
36	RPM182.307209	19T 1"Pitch Double Sprocket	1	
37	RPM182.307210	33T 1"Pitch Double Sprocket	1	
38	RPM196.306183	Washer	6	
39	RPM216.305697	Chain Guard Infill LH	1	
40	RPM226.303080	Guard Cone Profile	1	
41				
42	RPS200.458513	Oil Seal	2	
43	RPS200.508513	Oil Seal	2	
44				
45	RPT738.800100	1"Pitch Duplex Drive Chain	1	
46	RPT842.300762	Guard Cone	2	
47	RPT842.304224	Guard Cone	1	
48	RPT895.302614	Drive Coupling	1	
49				
50				
51				
52	W0167	Ø52 Internal Circlip	2	



Machines from Serial No QM154

Tractor Powered Hydraulics

Assy No 67115

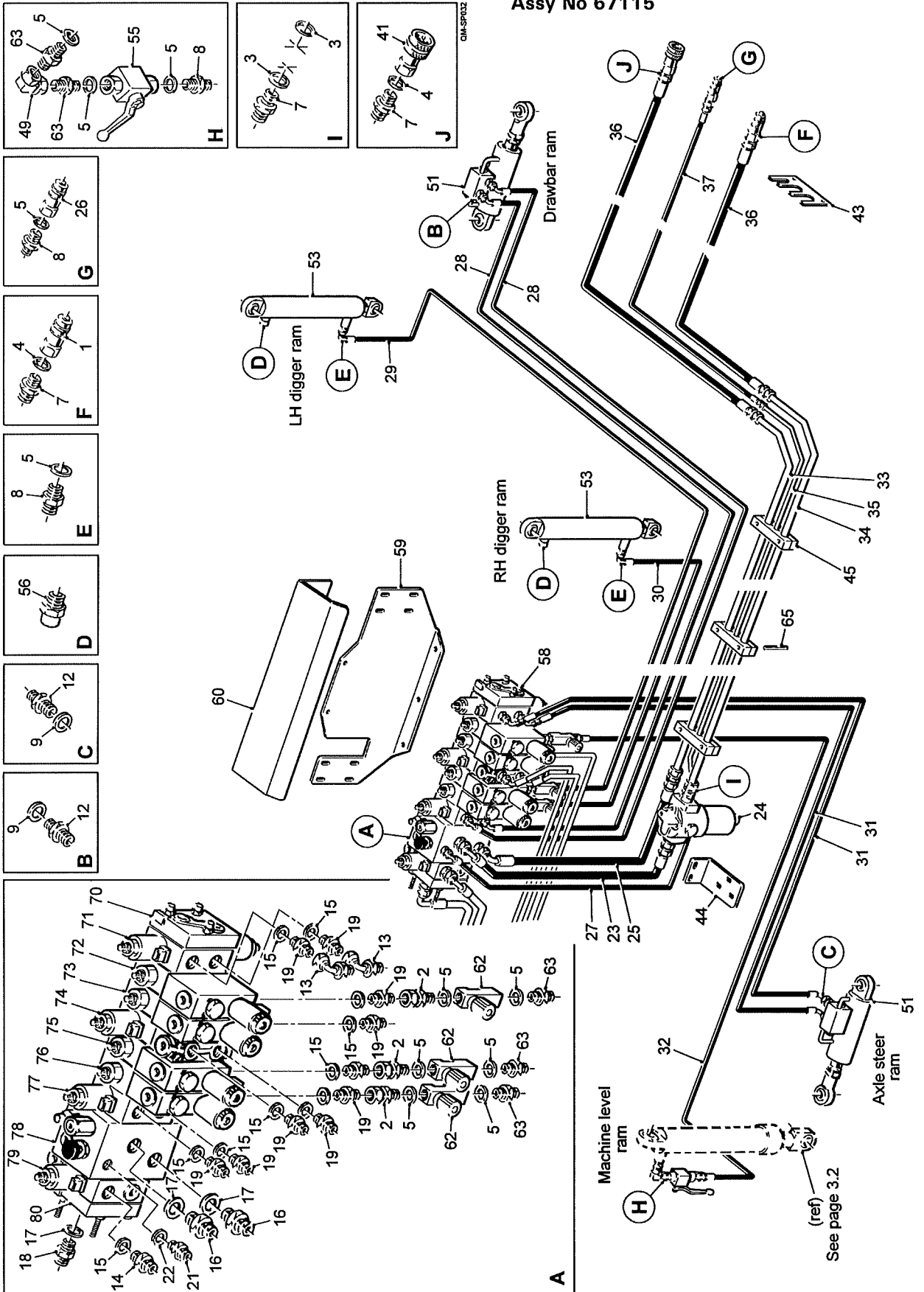

## 7.2a

## QUALITY MASTER SPARE PARTS

Machines from Serial No QM154

## Tractor Powered Hydraulics

Assy No 67115

Item	Part No.	Description	Qty.	Remarks
1	11108A	3/4"BSP Probe	1	Was 10140
2	10128	3/8"BSP M F Swivel Adaptor	3	
3	11123	3/4"BSP Dowty Seal	2	
4	11123	3/4"BSP Dowty Seal	2	Was 11124
5	11125	3/8"BSP Dowty Seal	11	
6				
7	11115	3/4"BSP M M Adaptor	2	Was 11295
8	11336	1/4"BSPx3/8"BSP M M Adaptor	2	
9	11337	1/4"BSP Dowty Seal	4	
10				
11				
12	12316	1/4"BSP M M Adaptor	4	
13	13189	3/8"BSP MF Swept 90° Adaptor	2	
14	27459	M18x1/2"BSP M M Adaptor	1	
15	27461	M18 Dowty Seal	11	
16	27904	M22x3/4"BSP M M Adaptor	2	
17	31167	M22 Dowty Seal	3	
18	31168	M22x1/2"BSP M M Adaptor	1	
19	37599	M18x3/8"BSP M M Adaptor	10	
20				
21	44207	M14x1/4"BSP M M Adaptor	1	
22	44208	M14 Dowty Seal	1	
23	44272	3/4"Hose Assembly (900mm)	1	
24	46859	Pressure Filter Complete	1	Element only 37770/1
25	46623	3/4"Hose Assembly (1000mm)	1	
26	60166	3/8"BSP Probe	1	
27	60234	1/4"Hose Assembly (850mm)	1	
28	60794	1/4"Hose Assembly (4800mm)	2	
29	60796	1/4"Hose Assembly (5810mm)	1	
30	60797	1/4"Hose Assembly (2500mm)	1	
31	60798	1/4"Hose Assembly (2250mm)	2	
32	60799	1/4"Hose Assembly (3200mm)	1	
33	60865	Ø25 Steel Pipe Assembly	1	
34	60866	Ø25 Steel Pipe Assembly	1	
35	60867	Ø10 Steel Pipe Assembly	1	
36	60953	3/4"Hose Assembly (3300mm)	2	
37	60954	1/4"Hose Assembly (3400mm)	1	
38				
39				
40				
41	61600	3/4"BSP Quick Release Fem Carrier	1	
42				
43	67340	Hose Carrier	1	
44	67032	Filter Bracket RH	1	
45	67075	Pipe Clamp (25-10-25)	3	
46				
47	RPC700.306200	Spiral Plastic Guard	a/r	Not shown
48				
49	RPH713.110606	3/8"BSP F F Elbow	1	
50				
51	RPH871.300142	Hydraulic Ram	2	
52				
53	RPH872.305668	Hydraulic Ram	2	
54				
55	RPH888.306444	3/8"BSP Gate Valve	1	

# QUALITY MASTER SPARE PARTS

7.2b

Machines from Serial No QM154

## Tractor Powered Hydraulics

Assy No 67115

Item	Part No.	Description	Qty.	Remarks
56	RPP500.202000	1/8" BSP Breather	2	
57				
58	RPS1233	Valve Bank Assembly	1	(see list at end)
59	RPS1236	Valve Mounting	1	
60	RPS1237	Valve Guard	1	
61				
62	KA17102	3/8" BSP Adjustable Restrictor	3	
63	UC31A	3/8" BSP M M Adaptor	5	
64				
65	22106008/065	M8x65 Studding	6	
	<b>RPS1233</b>	<b>Valve Bank Consists Of:</b>		
70	57085/2	End Plate	1	
71	RPS1233/2	Valve Section (axle steer)	1	
72	RPS1233/3	Valve Section (machine level)	1	
73	RPS1233/3	Valve Section (swan neck)	1	
74	RPS1233/4	Valve Section (elevator fold)	1	
75	RPS1233/3	Valve Section (LH digger)	1	
76	RPS1233/3	Valve Section (RH digger)	1	
77	RPS1233/2	Valve Section (drawbar)	1	
78	46285/4	Inlet Section	1	
79	RPS1233/5	Elevator Motor Section	1	
80	57085/2	End Plate	1	



Machines from Serial No QM154

Discharge Elevator Hydraulics

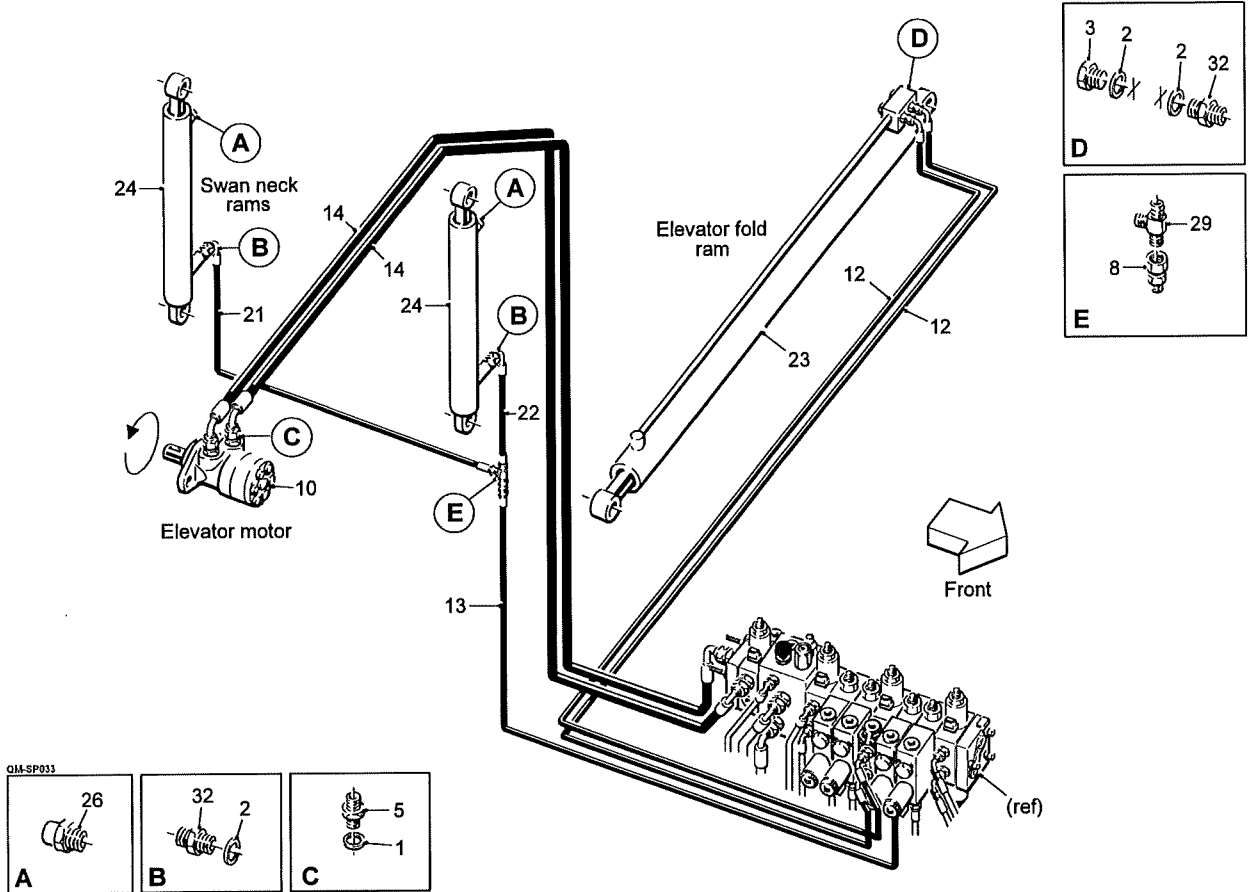

**7.3a****QUALITY MASTER SPARE PARTS**

Machines from Serial No QM154

**Discharge Elevator Hydraulics**

Item	Part No.	Description	Qty.	Remarks
1	11124	1/2"BSP Dowty Seal	2	
2	11125	3/8"BSP Dowty Seal	6	
3	11293	3/8"BSP Blanking Plug	2	
4				
5	12315	1/2"BSP M M Adaptor	2	
6				
7				
8	27894	3/8"BSPFx1/4"BSPM Swivel Adaptor	1	
9				
10	44563	Hydraulic Motor	1	
11				
12	60969	1/4"Hose Assembly (6200mm)	2	
13	60970	1/4"Hose Assembly (5050mm)	1	
14	*****	1/2"Hose Assembly (****mm)	2	
15				
16				
17				
18				
19				
20				
21	RPH430.306408	6mm Hose Assembly (2600mm)	1	
22	RPH430.306409	6mm Hose Assembly (430mm)	1	
23	RPH871.305809	Hydraulic Ram	1	
24	RPH872.305669	Hydraulic Ram	2	
25				
26	RPP500.202000	1/8"BSP Breather	2	
27				
28				
29	23139	3/8"BSP M M M Tee	1	
30				
31				
32	UC31A	3/8"BSP M M Adaptor	4	

Machines from Serial No QM154

Omega Separator Hydraulics

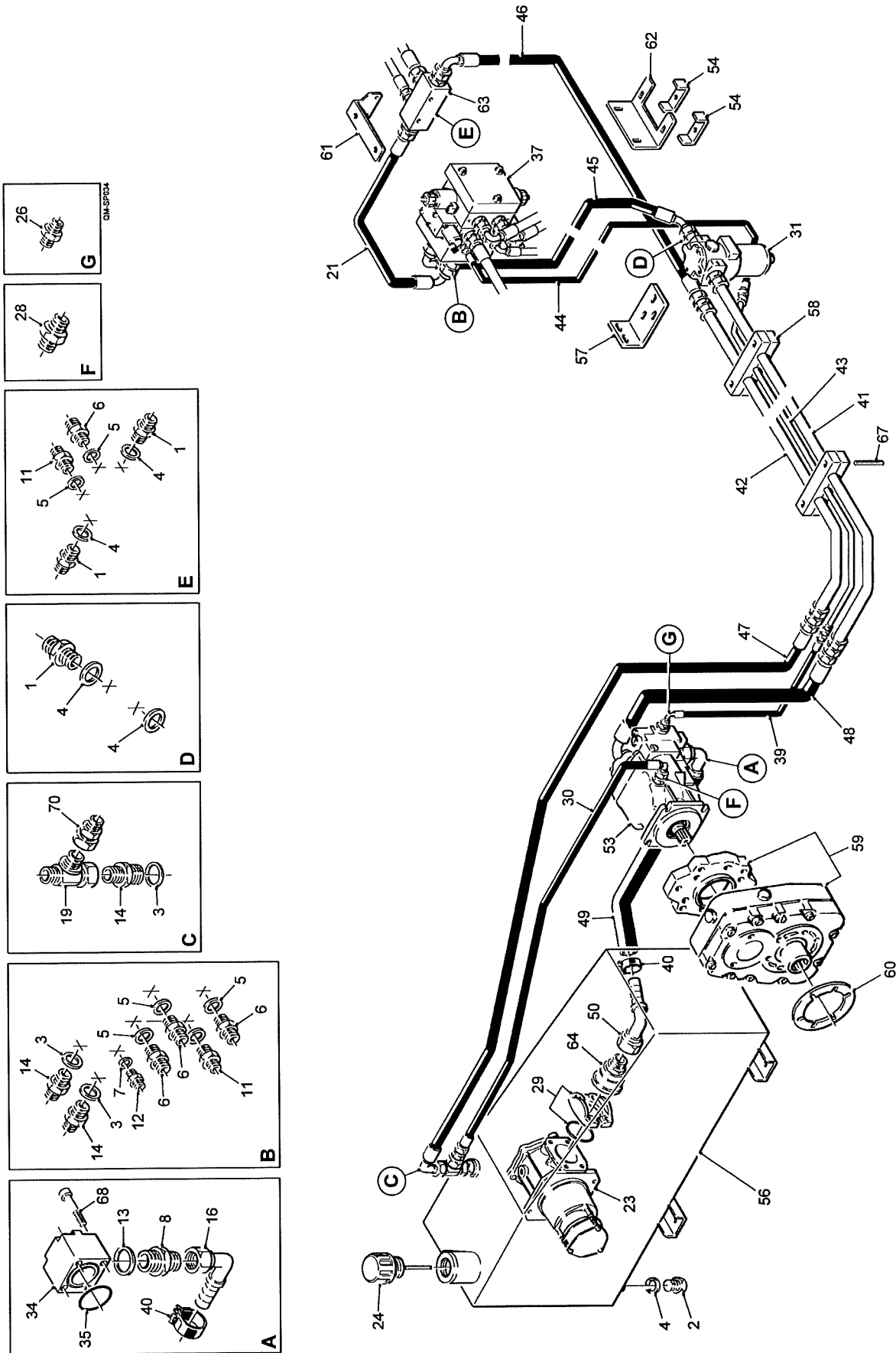

## 7.5a

## QUALITY MASTER SPARE PARTS

Machines from Serial No QM154

## Omega Separator Hydraulics

Item	Part No.	Description	Qty.	Remarks
1	11115	3/4"BSP M M Adaptor	3	
2	11117	3/4"BSP Blanking Plug	1	
3	11122	1"BSP Dowty Seal	3	
4	11123	3/4"BSP Dowty Seal	5	
5	11124	1/2"BSP Dowty Seal	6	
6	11295	1/2"BSPx3/4"BSP M M Adaptor	3	
7	11337	1/4"BSP Dowty Seal	1	
8	11737	1 1/4"BSPx1 1/2"BSP M M Adaptor	1	
9				
10				
11	12315	1/2"BSP M M Adaptor	2	
12	12316	1/4"BSP M M Adaptor	1	
13	12352	1 1/2"BSP Dowty Seal	1	
14	12560	3/4"BSPx1"BSP M M Adaptor	3	
15				
16	13299	1 1/4"BSP 90°Push-on Adaptor	1	
17				
18				
19	32512	3/4"BSP F M M Tee	1	
20				
21	41182	3/4"Hose Assembly (600mm)	1	
22				
23	42065	Suction Filter (seal kit only 42065S)	1	Element only 42065/1
24	42066	Filler Cap c/w Dipstick	1	
25				
26	44198	1/4"BSPx7/16"UNF M M Adaptor	1	
27				
28	46303	1/2"BSPx7/8"UNF M M Adaptor	1	
29	46503	2 1/2"Split Flange Kit	1	
30	46624	1/2"Hose Assembly (650mm)	1	
31	46859	Pressure Filter Complete	1	Element only 37770/1
32				
33				
34	56302	Pump Suction Adaptor	1	
35	56637	'O' Ring	1	
36				
37	59106	Separator Valve Block	1	
38				
39	60068	1/4"Hose Assembly (1750mm)	1	
40	60532	Ø37-40 Suction Hose Band	2	
41	60868	Ø25 Steel Pipe Assembly	1	
42	60869	Ø25 Steel Pipe Assembly	1	
43	60870	Ø10 Steel Pipe Assembly	1	
44	60948	1/4"Hose Assembly (3750mm)	1	
45	60949	3/4"Hose Assembly (2950mm)	1	
46	60950	3/4"Hose Assembly (2650mm)	1	
47	60951	3/4"Hose Assembly (1800mm)	1	
48	60952	1"Hose Assembly (2000mm)	1	
49	60955	1 1/4"Suction Hose (950mm)	1	
50	60956	1 1/4"BSP 45°Push-on Adaptor	1	
51				
52				
53	62030	Hydraulic Pump (65cc)	1	
54	62966	Pipe Clamp	2	
55				



**QUALITY MASTER SPARE PARTS****7.5b**

Machines from Serial No QM154

**Omega Separator Hydraulics**

Item	Part No.	Description	Qty.	Remarks
56	67004	Hydraulic Tank	1	
57	67031	Filter Bracket LH	1	
58	67075	Pipe Clamp (25-10-25)	3 pairs	
59	67093	Gearbox c/w Flange Kit	1	
60	67148	Spacer Plate	1	
61	67149	Manifold Mounting Bracket	1	
62	67150	Hose Support	1	
63	65587	Return Manifold	1	
64	67186	Suction Manifold	1	
65				
66				
67	22016008/065	M8x65 Studding	6	
68	22028050/325	1/2"UNCx3 1/4" Bolt	4	
69				
70	TBMW659	1/2"BSPM x3/4"BSPF Swivel Adaptor	1	



Omega 2nd & 3rd Clod Roller Direction Control  
 Assy No 67344

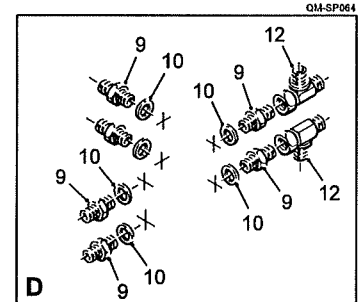
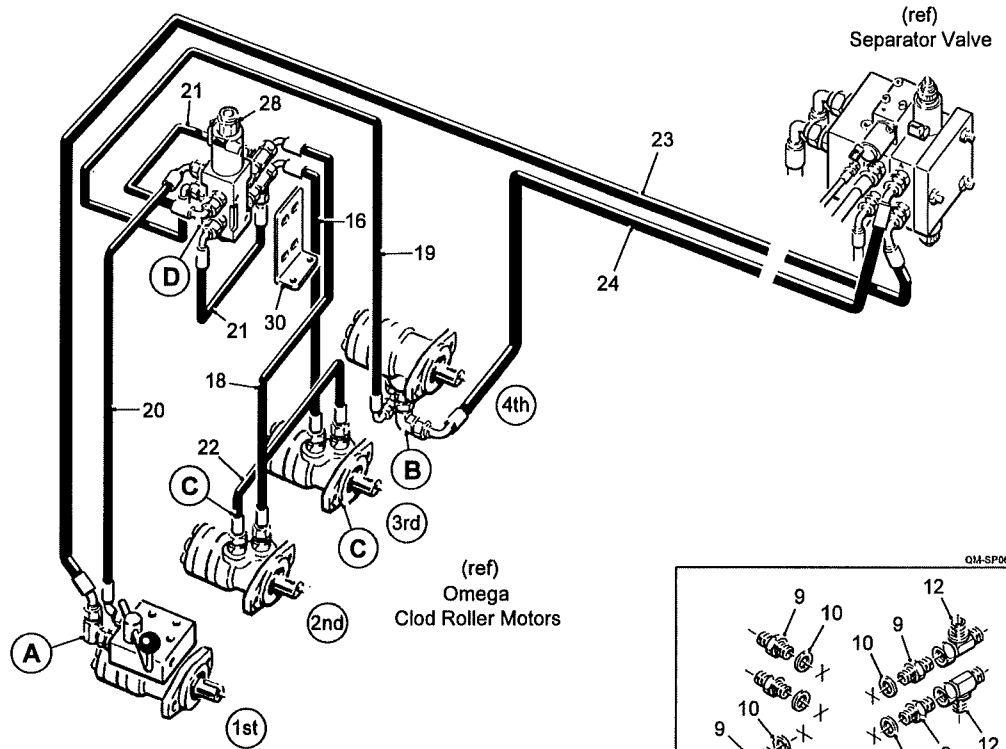
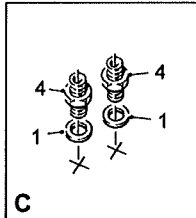
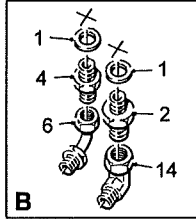
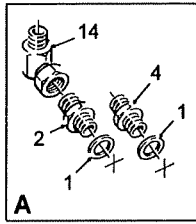

OM-SP064

**7.6a****QUALITY MASTER SPARE PARTS****Omega 2nd & 3rd Clod Roller Direction Control****Assy No 67344**

Item	Part No.	Description	Qty.	Remarks
1	11124	1/2"BSP Dowty Seal	8	
2	11295	1/2"BSPx3/4"BSP M M Adaptor	2	
3				
4	12315	1/2"BSP M M Adaptor	6	
5				
6	26086	1/2"BSP M F Swept 90° Adaptor	1	
7				
8				
9	27459	M18x1/2"BSP M M Adaptor	6	
10	27461	M18 Dowty Seal	6	
11				
12	37367	1/2"BSP M F M Tee	2	
13				
14	41115	3/4"BSP M F Compact 90° Adaptor	2	
15				
16	46624	1/2"Hose Assembly (650mm)	1	
17				
18	60357	1/2"Hose Assembly (750mm)	1	
19	71003	1/2"Hose Assembly (1100mm)	1	
20	60435	1/2"Hose Assembly (550mm)	1	
21	60562	1/2"Hose Assembly (500mm)	2	
22	60851	1/2"Hose Assembly (580mm)	1	
23	60943	3/4"Hose Assembly (2650mm)	1	
24	60944	3/4"Hose Assembly (1600mm)	1	
25				
26				
27				
28	62336	Hydraulic Valve	1	
29				
30	67343	Valve Mounting Plate	1	

Machines from Serial No QM154

Electrical Assembly

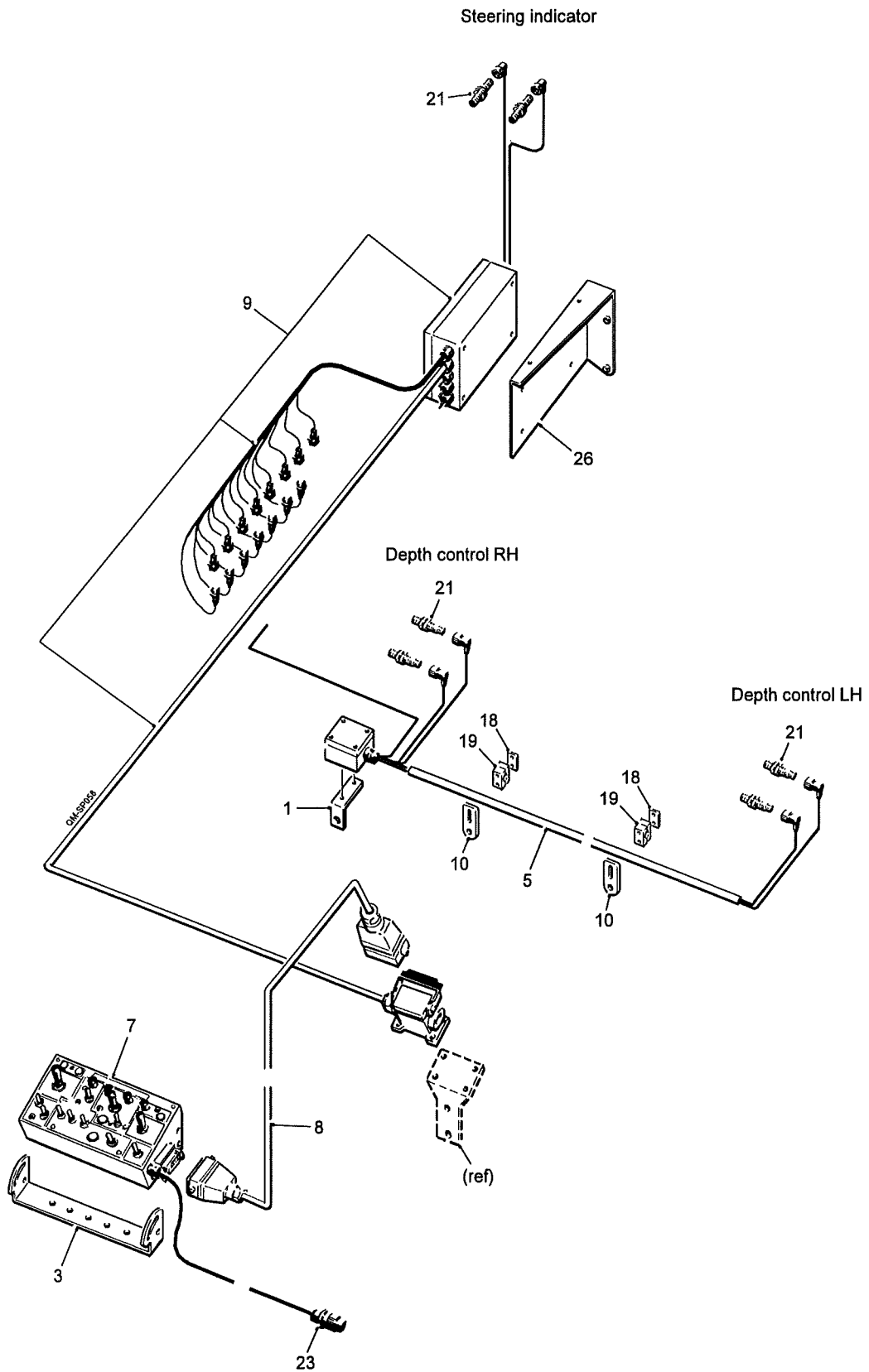

**7.9a****QUALITY MASTER SPARE PARTS**

Machines from Serial No QM154

**Electrical Assembly**

Item	Part No.	Description	Qty.	Remarks
1	46940	Bracket	1	
2				
3	61343	Control Box Mounting	1	
4				
5	67151	Ø15 Cable Tube (1000mm)	1	Was 62892
6				
7	67123	Control Box Complete	1	
8	67154	Link Loom Complete	1	
9	67155	Distribution Box and Loom Complete	1	
10	67366	Clamp Bracket	2	
11				
12				
13				
14				
15				
16				
17				
18	67153	Clamp Plate	2	Was RPC654.309025
19	67152	Ø15 Hose Clamp	2	Was RPS466
20				
21	RPE282.303483X/1	Proximity Sensor	6	
22				
23	RPGMB94.01478	3-Pin 'D' Plug	1	
24				
25				
26	RPS1238	Junction Box Mounting	1	

Machines from Serial No QM154

**Road Lights**  
Assy No 67090

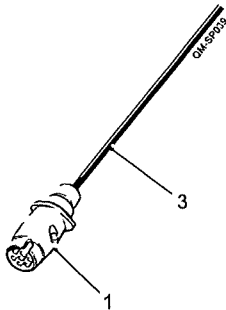
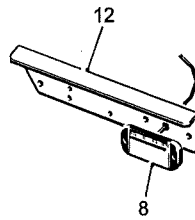
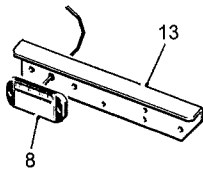
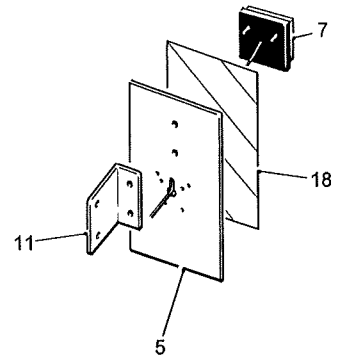
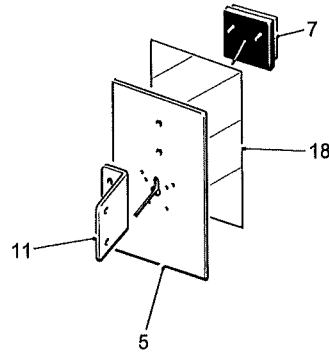

**7.10a****QUALITY MASTER SPARE PARTS**

Machines from Serial No QM154

**Road Lights****Assy No 67090**

Item	Part No.	Description	Qty.	Remarks
1	10134	7-Pin Plug	1	
2				
3	11369	7-Core Cable	a/r	
4				
5	59285A	Rear Light Plate	2	
6				
7	62217A	LED Rear Light	2	
8	62470	LED Front Light	2	
9				
10				
11	67035	Rear Light Mounting Bracket	2	
12	67041	Front Light Mounting LH	1	
13	67042	Front Light Mounting RH	1	
14				
15				
16				
17				
18	TR496	Red/White Stripe Reflector Decal	2	



Machines from Serial No QM154

**Clod Blocks Over Main Web**  
Assy No RPA580.306936

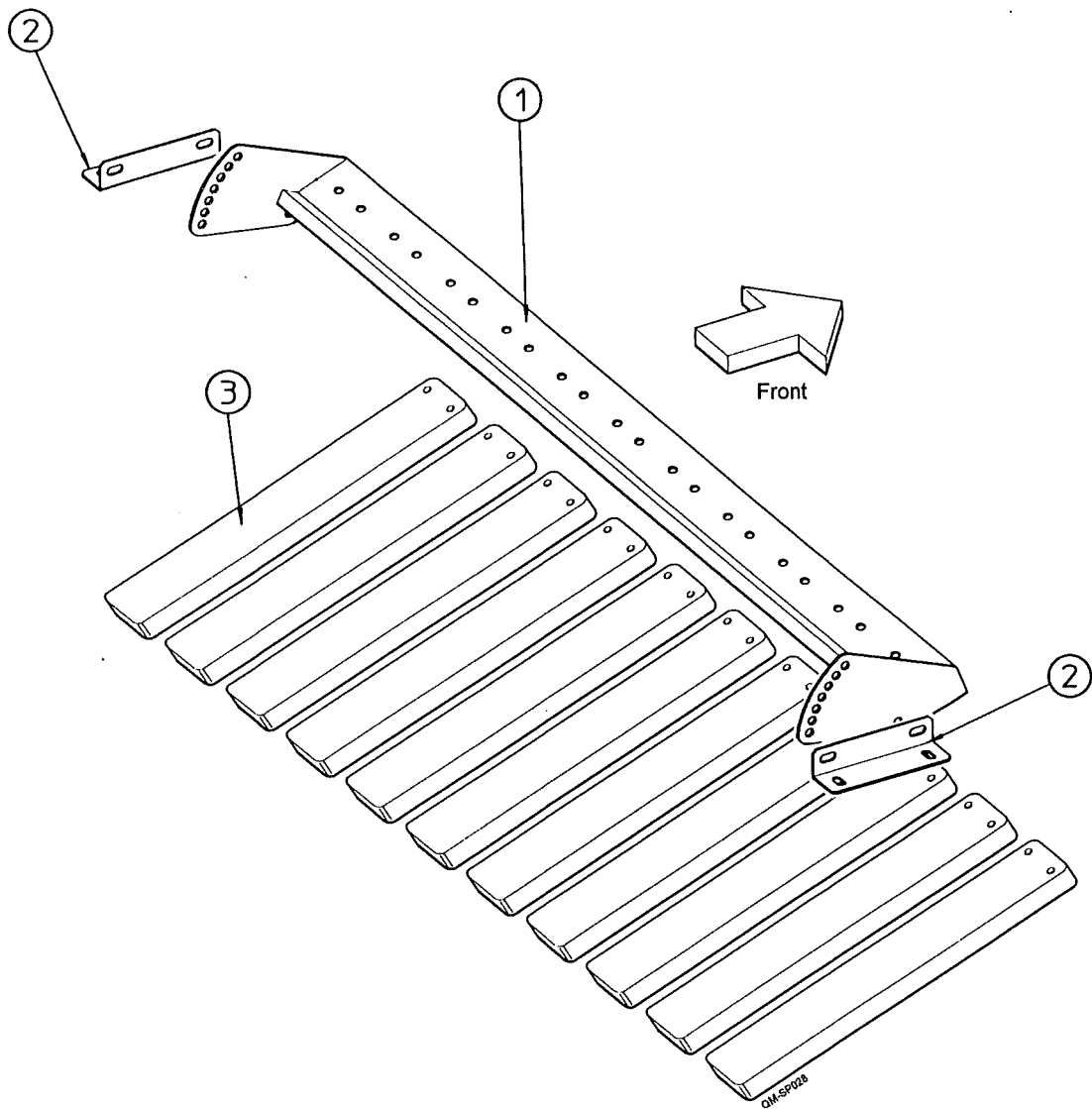

8.1a

**QUALITY MASTER SPARE PARTS**

Machines from Serial No QM154

**Clod Blocks Over Main Web**

**Assy No RPA580.306936**

Item	Part No.	Description	Qty.	Remarks
1	RPA610.306828	Mounting	1	
2	RPM236.301087	Mounting Bracket	2	
3	RPC700.301088	Rubber Block	11	

Machines from Serial No QM154

Web Cleaner

Assy No RPA580.306373

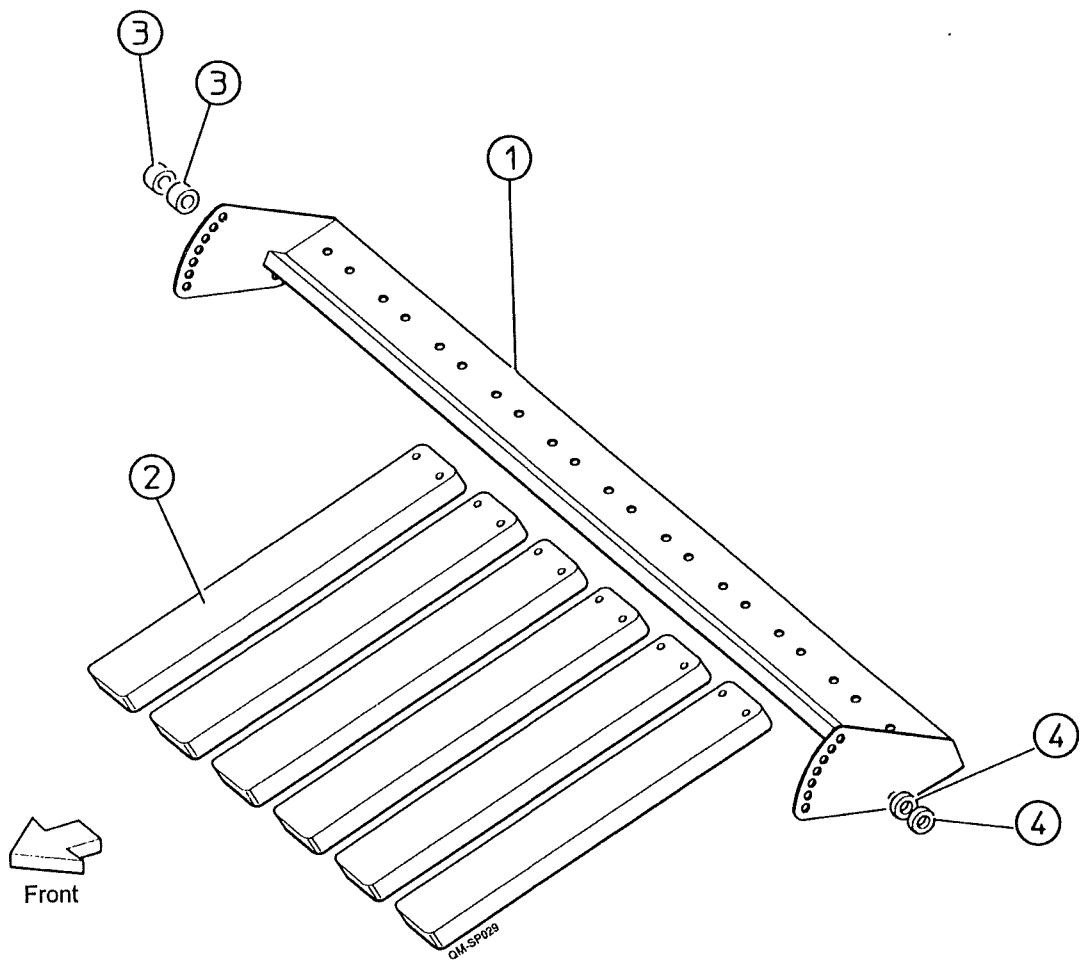

**8.2a****QUALITY MASTER SPARE PARTS**

Machines from Serial No QM154

**Web Cleaner****Assy No RPA580.306373**

<b>Item</b>	<b>Part No.</b>	<b>Description</b>	<b>Qty.</b>	<b>Remarks</b>
1	RPA610.306828	Mounting	1	
2	RPC700.301088	Rubber Block	11	
3	RPM176.306318	Spacer (20mm)	2	
4	RPM176.306319	Spacer (10mm)	2	

Machines from Serial No QM154

**Haulm Skis**

Assy No RPA580.310218

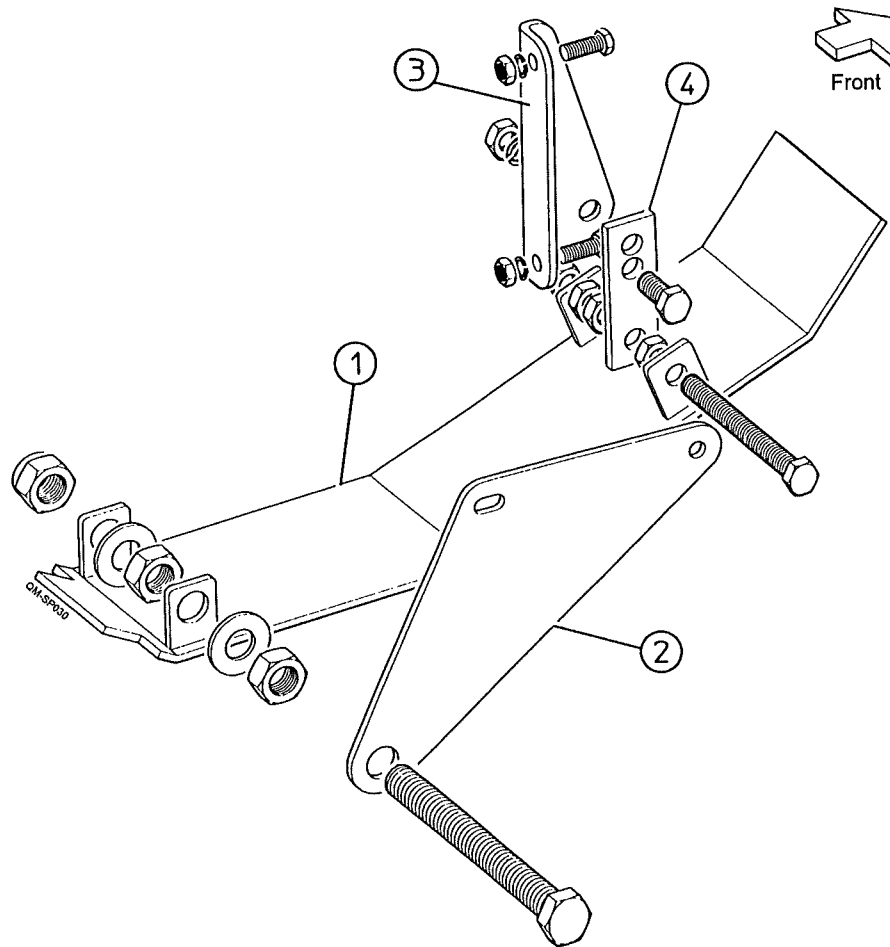

**8.3a****QUALITY MASTER SPARE PARTS**

Machines from Serial No QM154

**Haulm Skis****Assy No RPA580.310218**

<b>Item</b>	<b>Part No.</b>	<b>Description</b>	<b>Qty.</b>	<b>Remarks</b>
1	RPA610.301188	Haulm Ski	2	
2	RPM226.309876	Profile	1	
x	RPM226.301195	Mounting LH	1	
3	RPM226.301196	Mounting RH	1	
4	RPM254.301199	Strap	2	

Machines from Serial No QM154

2nd Agitator  
Assy No RPS595

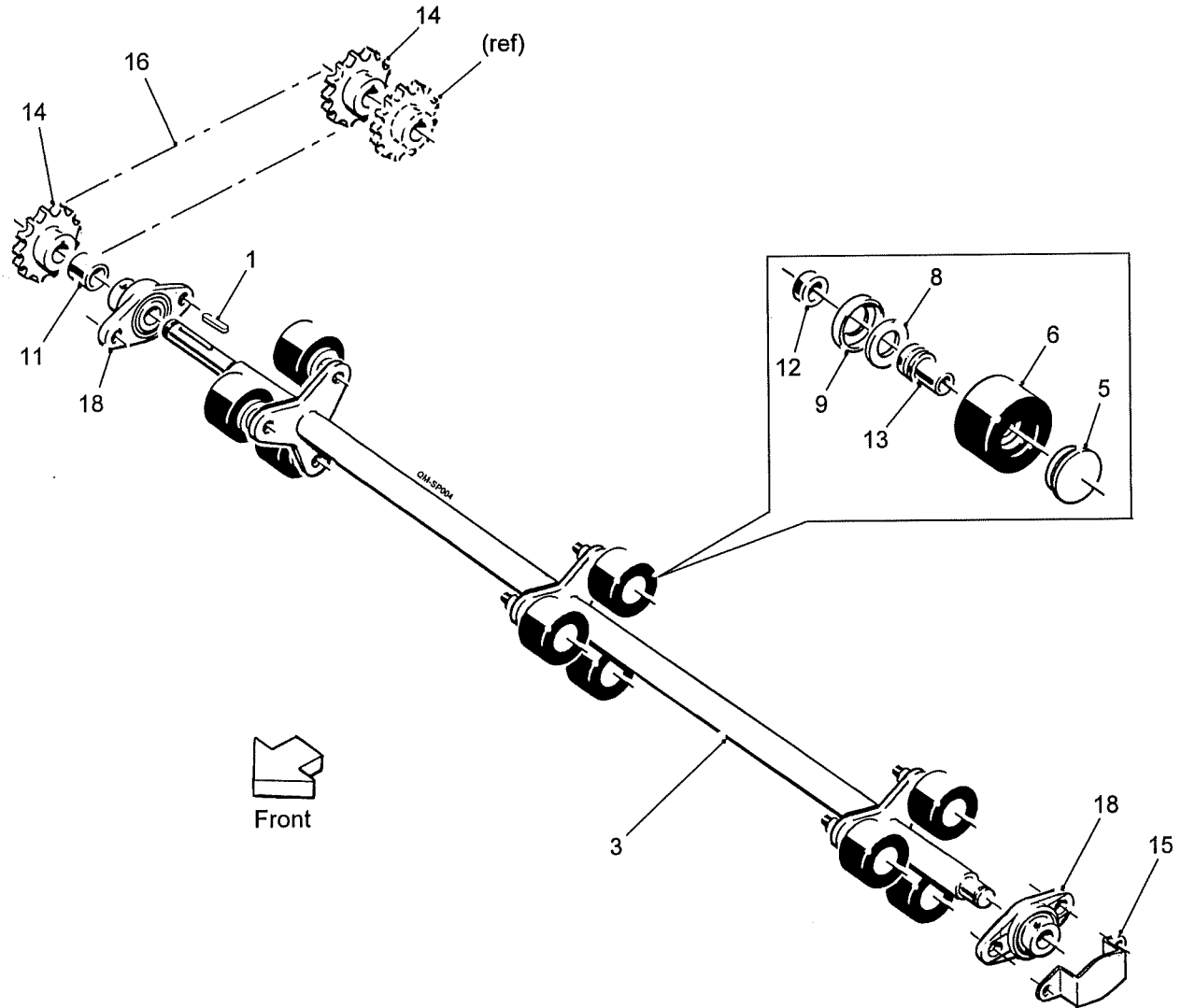

## 8.4a

## QUALITY MASTER SPARE PARTS

Machines from Serial No QM154

## 2nd Agitator

Assy No RPS595

Item	Part No.	Description	Qty.	Remarks
1	22062008/030	Rectangular Key (8x7x30)	2	
2				
3	RPA610.305728	Agitator Shaft	1	
4				
5	RPC620.303070	Cap	9	
6	RPC700.300148	Ø75 Plain Roller c/w Bearings	9	
7				
8	RPGM070.00446	Felt Seal	9	
9	RPGM089.00565	Roller Shield	9	
10				
11	RPM176.300356	Spacer (35mm)	1	
12	RPM176.306319	Spacer (10mm)	9	
13	RPM180.303071	Rollerr Spindle	9	
14	RPM182.300348	15T 3/4"Pitch Sprocket	2	
15	RPM216.301080	End Guard	1	
16	RPT732.6200**	3/4"Pitch Drive Chain	1	
17				
18	SFT30	Bearing	2	



Machines from Serial No QM154

Fall Breaker Kit

Assy No RPA580.311566

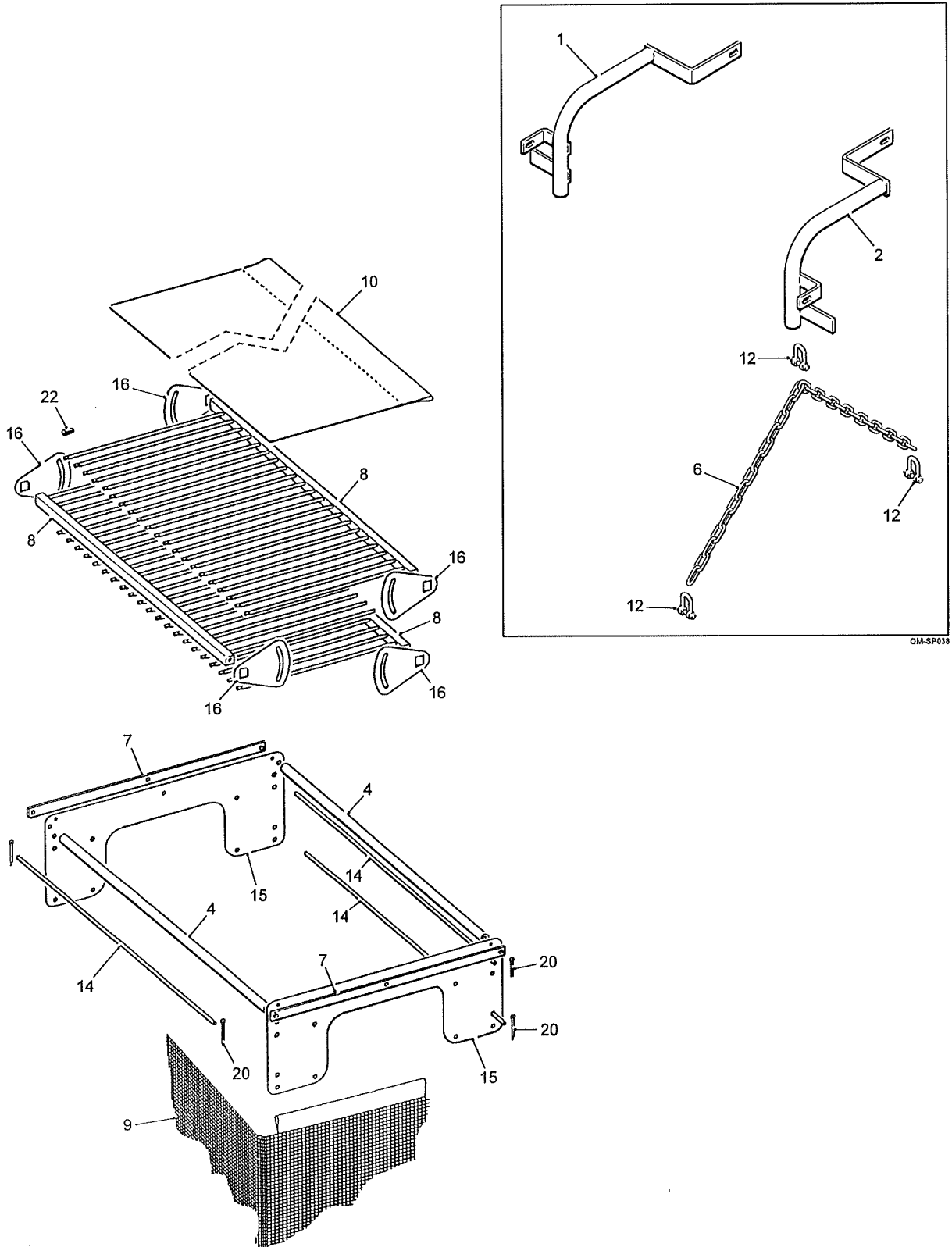

**8.5a****QUALITY MASTER SPARE PARTS**

Machines from Serial No QM154

**Fall Breaker Kit**

Assy No RPA580.311566

Item	Part No.	Description	Qty.	Remarks
1	RPA610.306781	Chute Bracket LH	1	
2	RPA610.306782	Chute Bracket RH	1	
3				
4	RPA610.311559	Spacer Bar (900mm)	2	
5				
6	RPC622.311064	Chain	2	
7	RPC700.311051	Support Strip	2	
8	RPC700.311562	Nylon Brush (900mm)	3	
9	RPC720.311564	Chute Cascade (900mm)	1	
10	RPC720.311565	Inner Flap (900mm)	3	
11				
12	RPGMRP099.00086	Shackle	6	
13				
14	RPM146.311561	Pin (900mm)	3	
15	RPM225.311043	Plate	2	
16	RPM225.311044	Plate	6	
17				
18				
19				
20	22078003/032	Ø3x32mm Split Pin	6	
21				
22	62331	Push-on Plastic Cap	28	

Machines from Serial No QM154

Haulm Intake Rollers

Haulm Intake Rollers for 2 Row Work

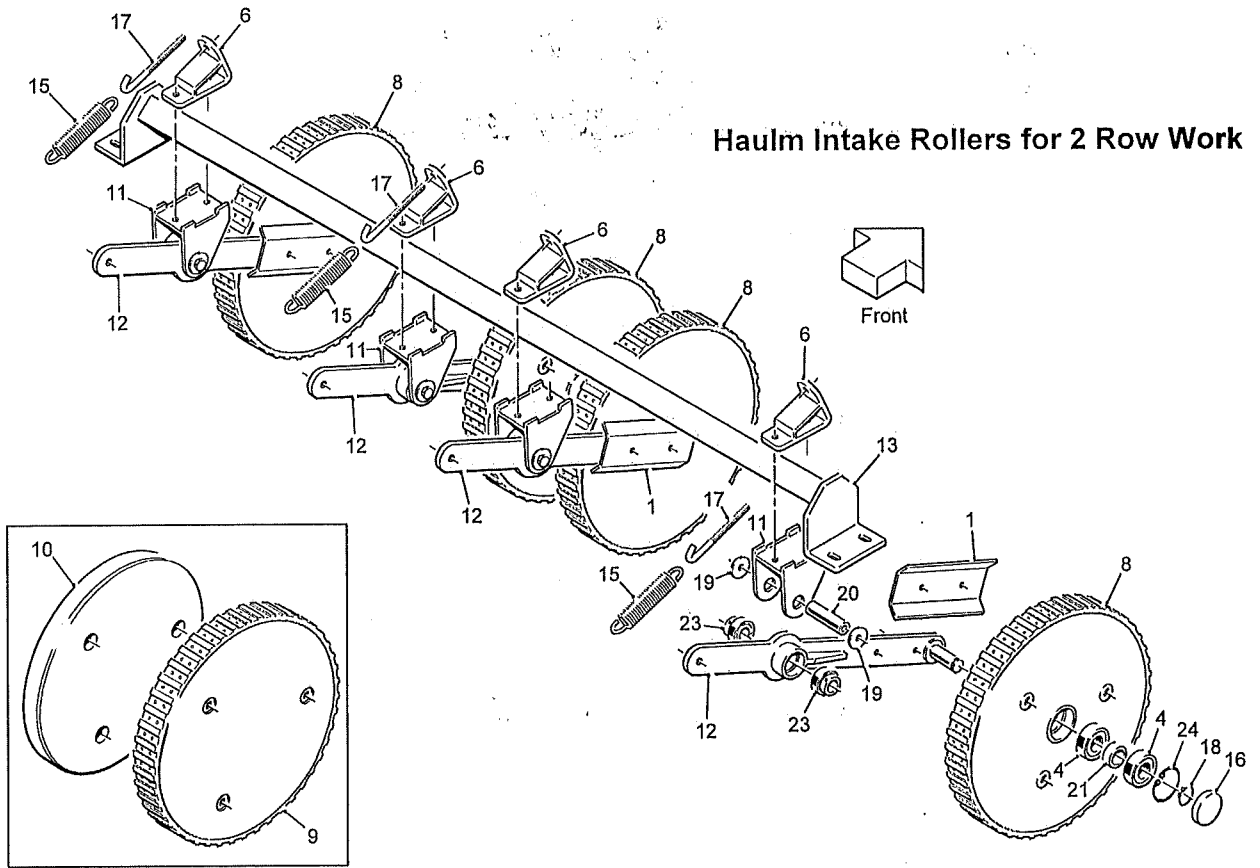

QM-SP041

Haulm Intake Rollers for Bed Work

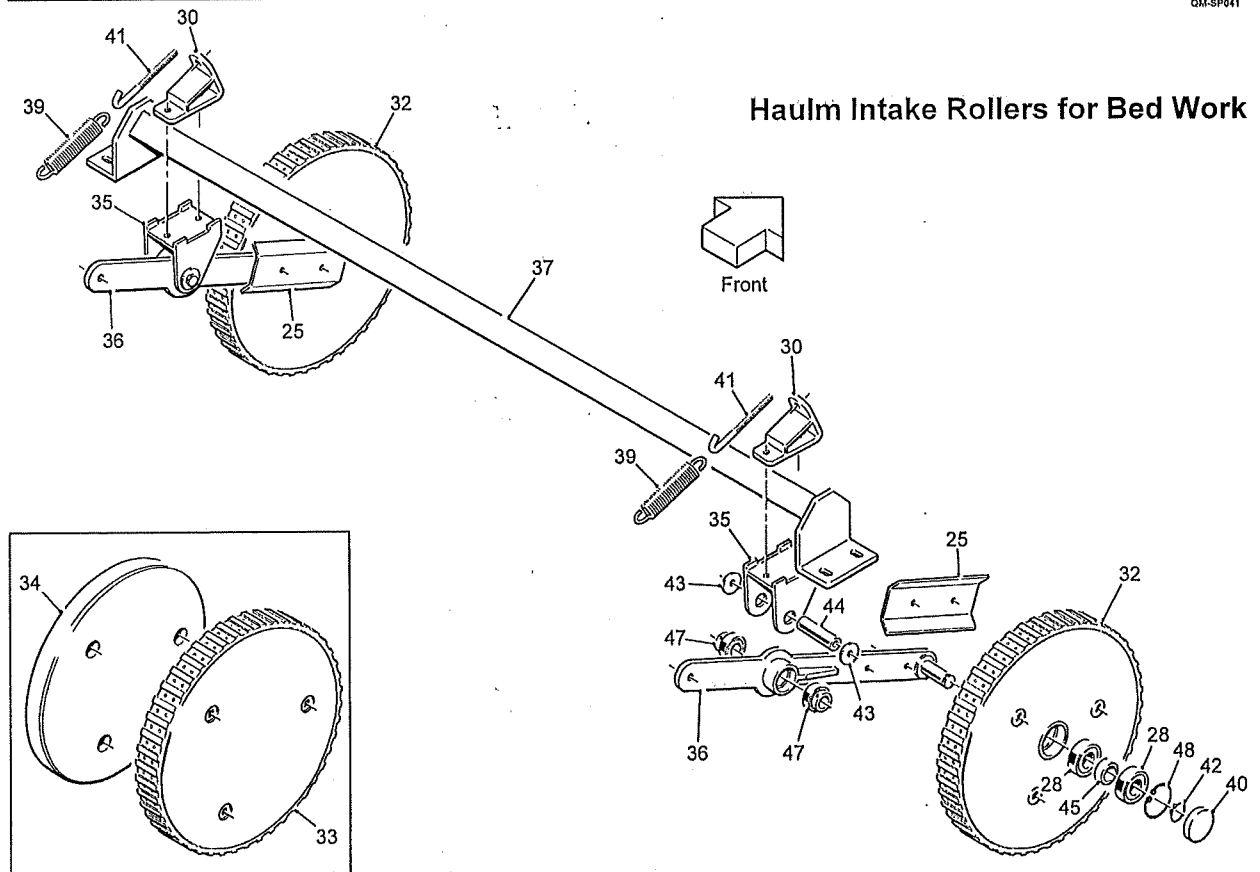

## 8.6a

## QUALITY MASTER SPARE PARTS

Machines from Serial No QM154

## Haulm Intake Rollers

Item	Part No.	Description	Qty.	Remarks
		<b>Haulm Intake Rollers for 2 Row Work Consists Of:</b>		
1	62896	Scraper	4	
2				
3				
4	62042RS	Bearing	8	
5				
6	RP305587A	Anchor Bracket	4	
7				
8	RPA510.300440	Haulm Feed Roller	4	
9	RPA510.300704	50mm Bolt-on Haulm Feed Roller	a/r	Optional
10	RPA610.300474	25mm Bolt-on Haulm Feed Roller	a/r	Optional
11	64731	Pivot Bracket	4	
12	64732	Mounting Arm	4	
13	RPA610.306753	Bridge	1	
14				
15	RPC676.302597	Spring	4	
16	RPC730.300988	Rubber Plug	4	
17	RPF128.110130	M10 Hook Bolt	4	
18	RPF200.020175	Ø20 External Circlip	4	
19	SS040011/003	Washer	8	
20	64733	Pivot Pin	4	
21	RPM176.300469	Spacer	4	
22				
23	1120-20	Bearing	4	
24	W0113	Ø47 Internal Circlip	4	
		<b>Haulm Intake Rollers for Bed Work Consists Of:</b>		
25	62896	Scraper	2	
26				
27				
28	62042RS	Bearing	4	
29				
30	RP305587A	Anchor Bracket	2	
31				
32	RPA510.300440	Haulm Feed Roller	2	
33	RPA510.300704	50mm Bolt-on Haulm Feed Roller	a/r	Optional
34	RPA610.300474	25mm Bolt-on Haulm Feed Roller	a/r	Optional
35	64731	Pivot Bracket	2	
36	64732	Mounting Arm	2	
37	RPA610.306753	Bridge	1	
38				
39	RPC676.302597	Spring	2	
40	RPC730.300988	Rubber Plug	2	
41	RPF128.110130	M10 Hook Bolt	2	
42	RPF200.020175	Ø20 External Circlip	2	
43	SS040011/003	Washer	4	
44	64733	Pivot Pin	2	
45	RPM176.300469	Spacer	2	
46				
47	1120-20	Bearing	4	
48	W0113	Ø47 Internal Circlip	2	

Machines from Serial No QM154

Easi-pic Table (2 pickers)

Assy No 67134

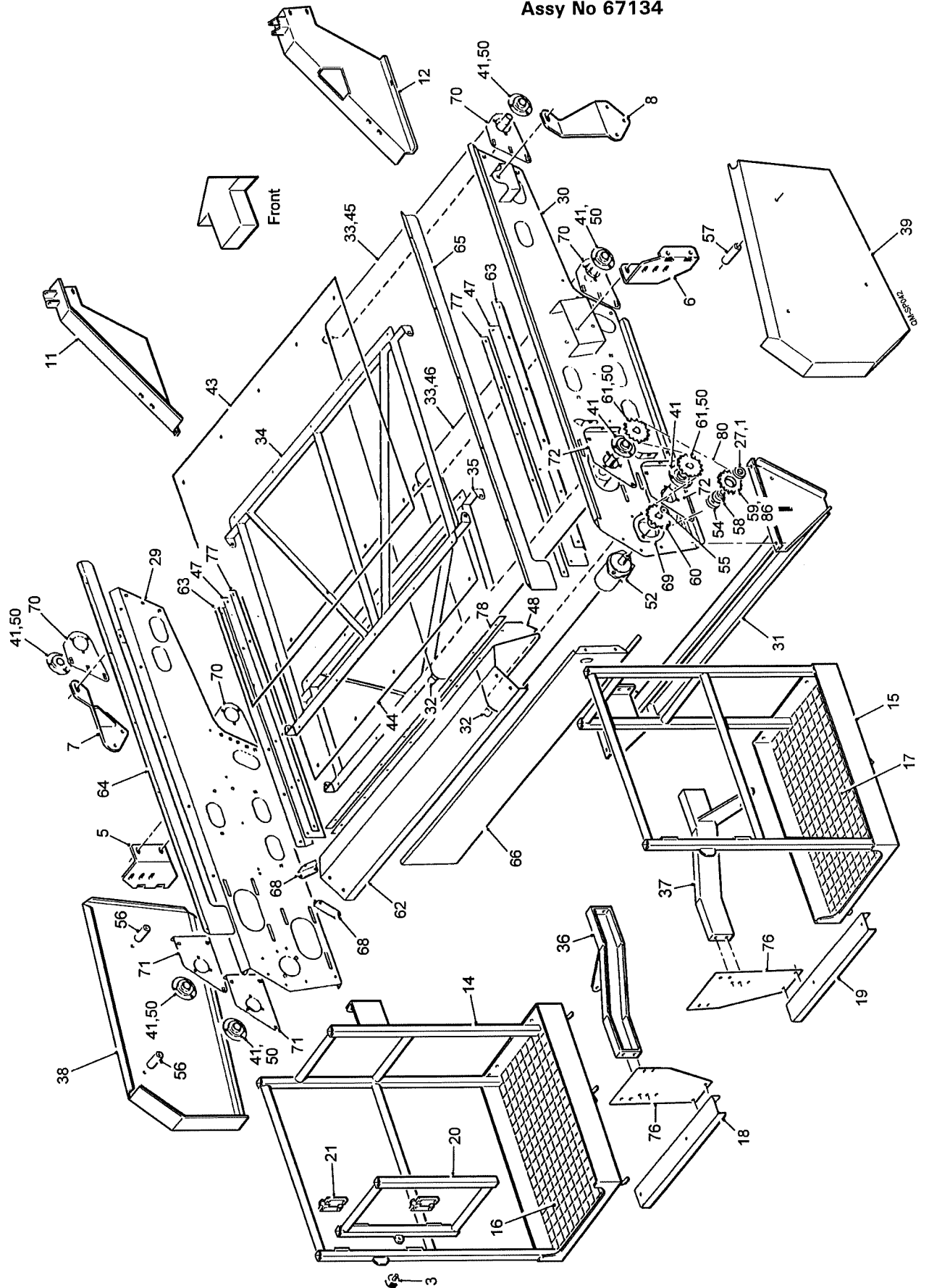

# 8.7a

# QUALITY MASTER SPARE PARTS

Machines from Serial No QM154

## Easi-pic Table (2 pickers)

Assy No 67134

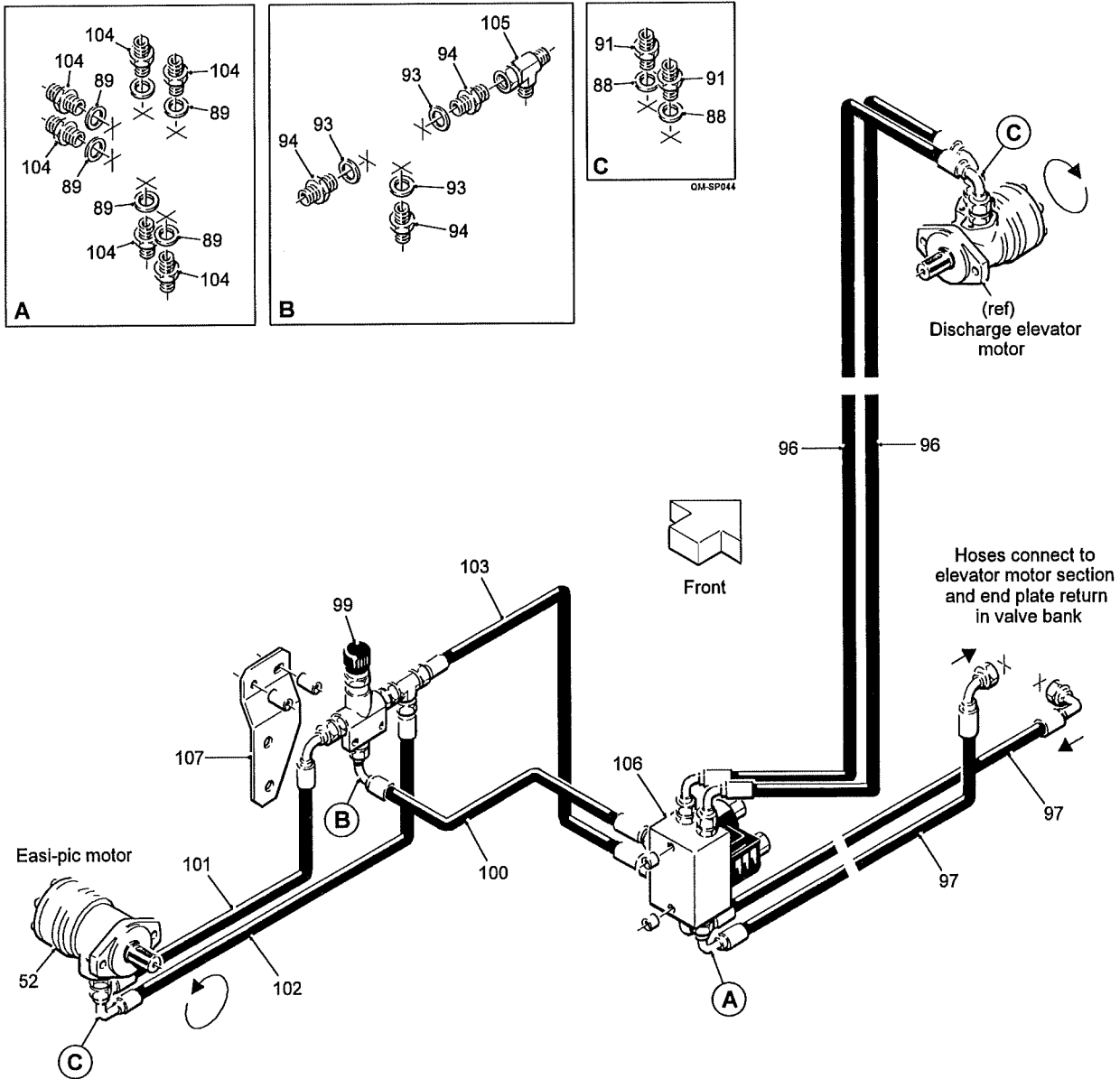

**QUALITY MASTER SPARE PARTS****8.7b**

Machines from Serial No QM154

**Easi-pic Table (2 pickers)****Assy No 67134**

Item	Part No.	Description	Qty.	Remarks
1	12298	Ø20 External Circlip	1	
2				
3	43288	Bump Stop	1	
4				
5	67309	Mounting Bracket Rear LH	1	
6	67310	Mounting Bracket Rear RH	1	
7	67307	Mounting Bracket Front LH	1	
8	67308	Mounting Bracket Front RH	1	
9				
10				
11	67141	Infill Panel LH	1	
12	67142	Infill Panel RH	1	
13				
14	67189	Platform LH	1	
15	67190	Platform RH	1	
16	67192L	Platform Base LH	1	
17	67192R	Platform Base RH	1	
18	67193L	Support Channel LH	1	
19	67193R	Support Channel RH	1	
20	67194	Platform Gate	2	
21	67199	Spring Hinge	4	
22				
23				
24				
25				
26				
27	62042RS	Bearing	1	
28				
29	RPA610.306463	Conveyor Side Panel LH	1	
30	RPA610.306464	Conveyor Side Panel RH	1	
31	RPA610.306479	Cross Member	1	
32	RPA610.306506	Drive Drum	2	
33	RPA610.306507	Idler Drum	2	
34	RPA610.306512	Cross Frame Top	1	
35	RPA610.306515	Cross Frame Bottom	1	
36	67305	Side Member LH	1	
37	67306	Side Member RH	1	
38	RPA610.306834	Guard LH	1	
39	RPA610.306837	Guard RH	1	
40				
41	RPB210.022052	Bearing Complete	8	
42				
43	RPC700.306509	Slider Bed Top	1	
44	RPC700.306510	Slider Bed Bottom	1	
45	RPC710.306800	Conveyor Belt Top	1	
46	RPC710.306801	Conveyor Belt Bottom	1	
47	RPC730.306520	Sealing Strip	2	
48	RPC730.306524	Sealing Strip	1	
49				
50	RPF200.025200	Ø25 External Circlip	8	
51				
52	RPH850.302352	Hydraulic Motor	1	
53				
54	RPM176.306829	Spacer	1	
55	RPM176.306833	Spacer	1	

## 8.7c

## QUALITY MASTER SPARE PARTS

Machines from Serial No QM154

Easi-pic Table (2 pickers)

Assy No 67134

Item	Part No.	Description	Qty.	Remarks
56	RPM176.306974	Spacer	2	
57	RPM176.306975	Spacer	3	
58	RPM180.305086	Spindle	1	
59	RPM182.306353	15T 3/4"Pitch Tensioner Sprocket	1	
60	RPM182.306830	15T 3/4"Pitch Motor Sprocket	1	
61	RPM182.306832	15T 3/4"Pitch Sprocket	2	
62	RPM224.306480	Rear Panel Top	1	
63	RPM224.306519	Mounting Strip	2	
64	RPM224.306522	Stainless Steel Panel LH	1	
65	RPM224.306523	Stainless Steel Panel RH	1	
66	RPM224.307129	Rear Panel Bottom	1	
67				
68	RPM225.306465	Angle Plate	4	
69	RPM225.306466	Motor Plate	1	
70	RPM225.306624	Bearing Plate Front	4	
71	RPM225.306625	Bearing Plate Rear LH	2	
72	RPM225.306626	Bearing Plate Rear RH	2	
73				
74				
75				
76	RPM225.307130	Platform Mounting Plate	2	
77	RPM256.306521	Clamp Strip	2	
78	RPM256.306525	Clamp Strip	1	
79				
80	RPT732.620082	3/4"Pitch Drive Chain	1	
81				
82				
83				
84				
85				
86	W0113	Ø47 Internal Circlip	1	
87				
		<b>Hydraulic Components Consist Of:</b>		
88	11124	1/2"BSP Dowty Seal	4	
89	11125	3/8"BSP Dowty Seal	6	
90				
91	12315	1/2"BSP M M Adaptor	4	
92				
93	31167	M22 Dowty Seal	3	
94	31168	M22x1/2"BSP M M Adaptor	3	
95				
96	60795	1/2"Hose Assembly (5460mm)	2	
97	60972	1/2"Hose Assembly (3200mm)	2	
98				
99	RPGMB92.03282	Speed Control Valve	1	
100	RPH405.306981	1/2"Hose Assembly (1630mm)	1	
101	RPH405.306982	1/2"Hose Assembly (1350mm)	1	
102	RPH405.306983	1/2"Hose Assembly (1380mm)	1	
103	RPH405.306984	1/2"Hose Assembly (1410mm)	1	
104	RPH700.110608	3/8"BSPx1/2"BSP M M Adaptor	6	
105	RPH724.110808	1/2"BSP M F M Tee	1	
106	RPH888.302717	Control Block	1	
107	RPM225.306985	Mounting Plate	1	



Machines from Serial No QM154

**Easi-pic Canopy (2 pickers)**

Assy No 67198

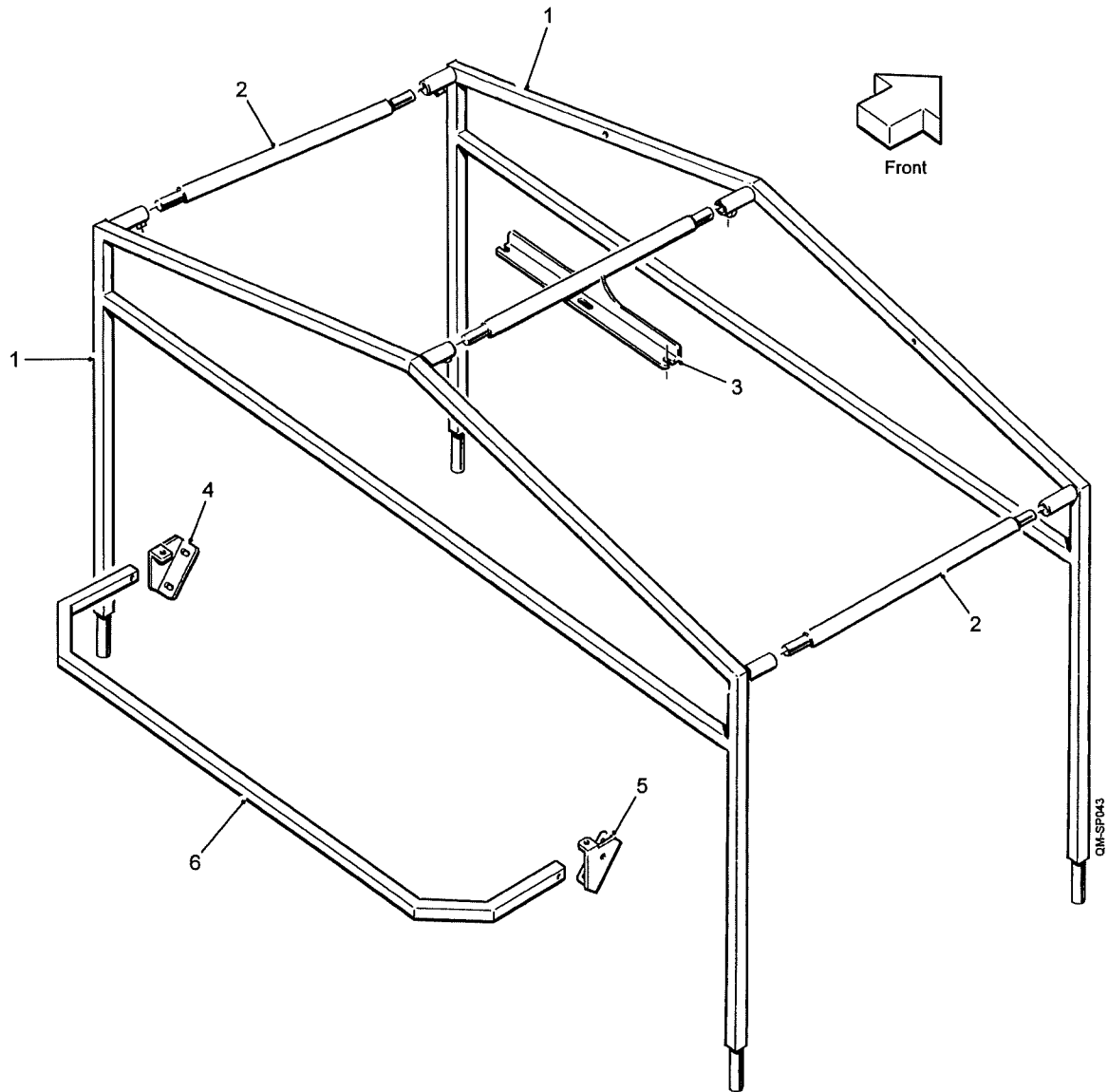

**8.8a****QUALITY MASTER SPARE PARTS**

Machines from Serial No QM154

**Easi-pic Canopy (2 pickers)****Assy No 67198**

<b>Item</b>	<b>Part No.</b>	<b>Description</b>	<b>Qty.</b>	<b>Remarks</b>
1	67188	Canopy Frame	2	
2	67191	Cross Tube Outer	2	
3	67191A	Cross Tube Centre	1	
4	67195	Support Mounting LH	1	
5	67196	Support Mounting RH	1	
6	67197	Rear Canopy Support	1	
7				
8				
9				
10	RPC720.307075	Canopy Cover		(not shown)

Machines from Serial No QM154

**Easi-pic Table (4 pickers)**  
Assy No 67295

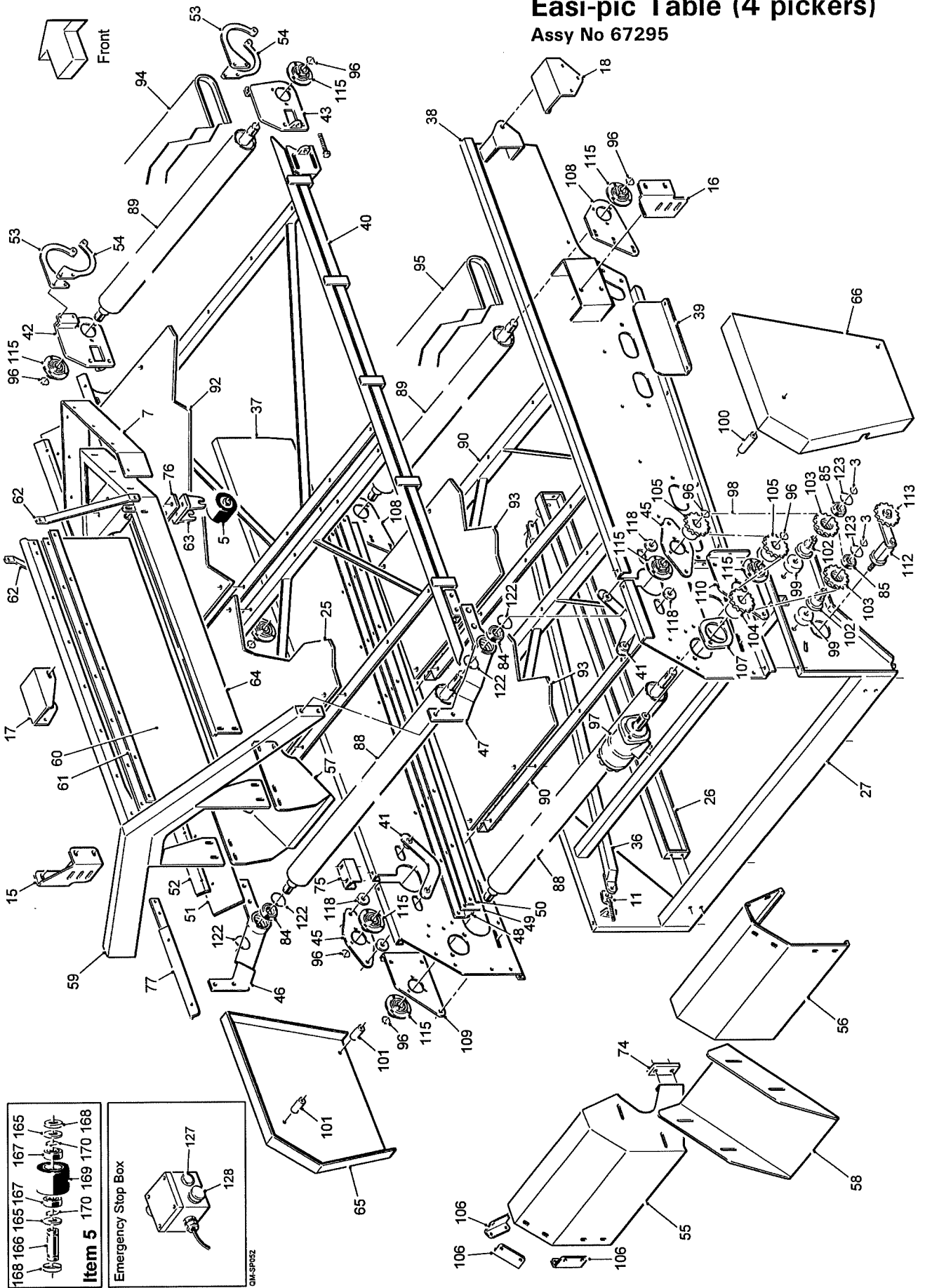

# 8.9a

# QUALITY MASTER SPARE PARTS

Machines from Serial No QM154

**Easi-pic Table (4 pickers)**  
Assy No 67295

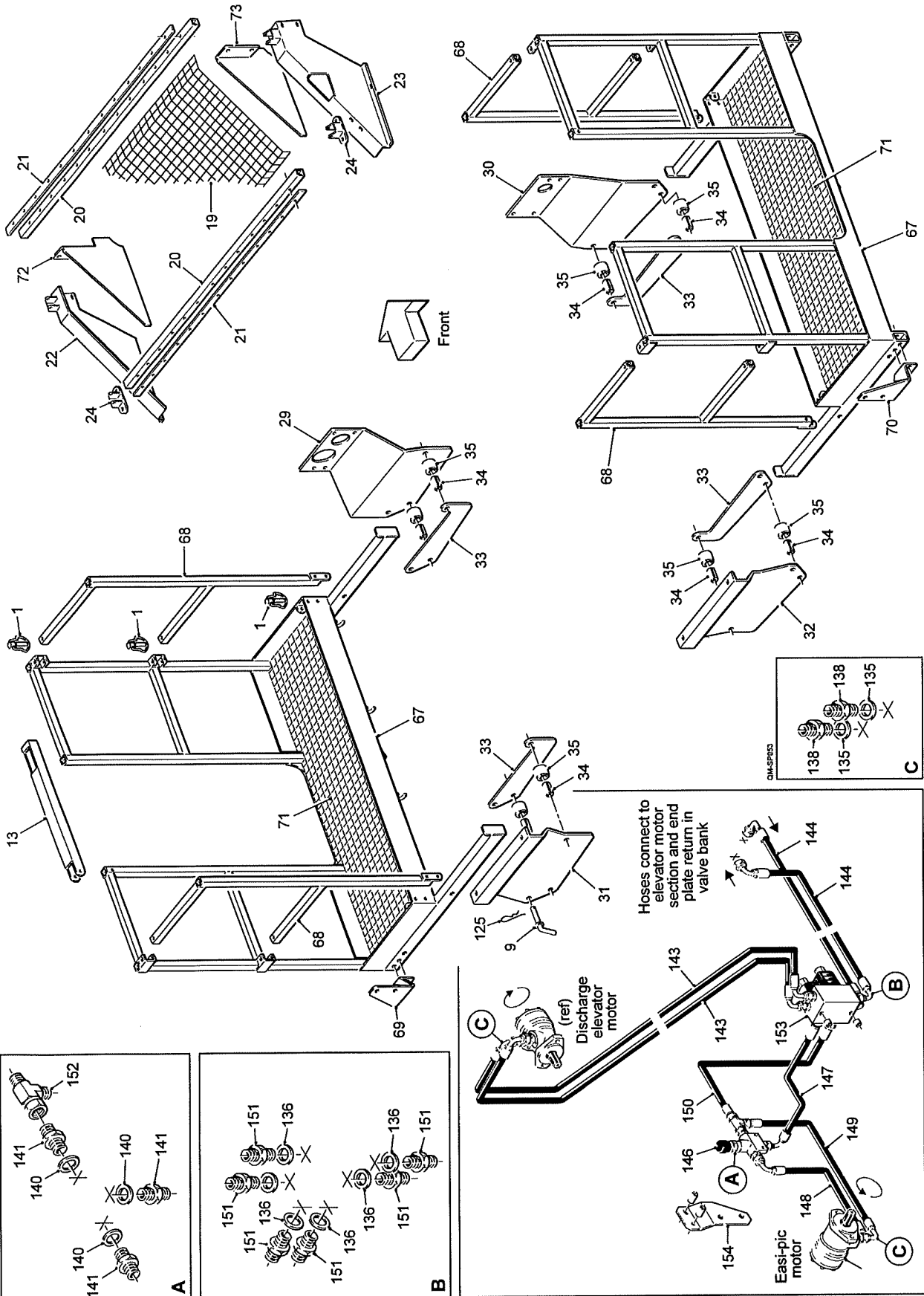

**QUALITY MASTER SPARE PARTS****8.9b**

Machines from Serial No QM154

**Easi-pic Table (4 pickers)****Assy No 67295**

Item	Part No.	Description	Qty.	Remarks
1	10282	Quick Release Pin	12	
2				
3	12298	Ø20 External Circlip	2	
4				
5	27200	Roller Assembly	1	(see list at end)
6				
7	44742	Divider Rubber Skirt	1	
8				
9	52673	Locking Pin	4	
10				
11	59677	Adjuster	2	
12				
13	62976	Safety Hand Rail	2	
14				
15	67129	Mounting Bracket Rear LH	1	
16	67130	Mounting Bracket Rear RH	1	
17	67131	Mounting Bracket Front LH	1	
18	67132	Mounting Bracket Front RH	1	
19	67138	Mesh Sheet	1	
20	67139	Mesh Mounting Bar	2	
21	67140	Clamp Strip	2	
22	67141	Infill Panel LH	1	
23	67142	Infill Panel RH	1	
24	67169	Bar Mounting Bracket	2	
25	67233	Nylon Panel Top	1	
26	67234	Support Beam	2	
27	67235	Conveyor Support	1	
28				
29	67237	Support Bracket Front LH	1	
30	67238	Support Bracket Front RH	1	
31	67239	Support Bracket Rear LH	1	
32	67240	Support Bracket Rear RH	1	
33	67241	Support Plate	4	
34	67242	Roller Spindle	8	
35	67243	Roller	8	
36	67244	Tie Brace	2	
37	67247	Side Panel LH	1	
38	67248	Side Panel RH	1	
39	67250	Shield	4	
40	67253	Cross Frame Top	1	
41	67254	Keep Bracket	2	
42	67255	Front Roller Mounting LH	1	
43	67256	Front Roller Mounting RH	1	
44				
45	67258	Bearing Plate	2	
46	67259	Rear Roller Mounting LH	1	
47	67260	Rear Roller Mounting RH	1	
48	67262	Mounting Strip	2	
49	67263	Sealing Strip	2	
50	67264	Clamp Strip	2	
51	67265	Sealing Strip	2	
52	67266	Clamp Strip	2	
53	67267	Link Plate Top	2	
54	67268	Link Plate Bottom	2	
55	67269	Rear Panel LH	1	

## 8.9c

## QUALITY MASTER SPARE PARTS

Machines from Serial No QM154

Easi-pic Table (4 pickers)

Assy No 67295

Item	Part No.	Description	Qty.	Remarks
56	67270	Rear Panel RH	1	
57	67271	Trash Chute Upper	1	
58	67272	Trash Chute Lower	1	
59	67274	Divider Support Bracket	1	
60	67276	Rubber Divider	1	
61	67277	Clamp Strip	1	
62	67278	Support Strap	2	
63	67279	Roller Mounting	1	
64	67280	Centre Divider	1	
65	67281	Drive Guard LH	1	
66	67282	Drive Guard RH	1	
67	67283	Platform	2	
68	67284	Platform End Rail	4	
69	67285	Light Mounting LH	1	
70	67286	Light Mounting RH	1	
71	67287	Platform Base	2	
72	67300	Omega Deflector LH	1	
73	67301	Omega Deflector RH	1	
74	67302	Clamp Plate	2	
75	67303	Cover Plate	2	
76	67377	Packer Plate	a/r	
77	67378	Extension Bracket	1	
78				
79				
80				
81				
82				
83				
84	60062RS	Bearing	2	
85	62042RS	Bearing	2	
86				
87				
88	RPA610.306506	Drive Drum	2	
89	RPA610.306507	Idler Drum	2	
90	RPA610.306515	Cross Frame Bottom	2	
91				
92	RPC700.306509	Nylon Panel Top	1	
93	RPC700.306510	Nylon Panel Bottom	2	
94	RPC710.306800A	Conveyor Belt Top	1	
95	RPC710.306801A	Conveyor Belt Bottom	1	
96	RPF200.025200	Ø25 External Circlip	8	
97	RPH850.302352	Hydraulic Motor	1	
98	RPT732.620092	3/4"Pitch Drive Chain	1	
99	RPM176.306829	Spacer	2	
100	RPM176.306974A	Tapped Spacer (40mm)	2	
101	RPM176.306975	Tapped Spacer (80mm)	2	
102	RPM180.305086	Spindle	2	
103	RPM182.306353	15T 3/4"Pitch Idler Sprocket	2	
104	RPM182.306830	15T 3/4"Pitch Motor Sprocket	1	
105	RPM182.306832	15T 3/4"Pitch Sprocket	2	
106	RPM225.306465	Angle Plate	6	
107	RPM225.306466	Motor Plate	1	
108	RPM225.306624	Bearing Plate Front	2	
109	RPM225.306625	Bearing Plate Rear LH	1	
110	RPM225.306626	Bearing Plate Rear RH	1	

# QUALITY MASTER SPARE PARTS

8.9d

Machines from Serial No QM154

## Easi-pic Table (4 pickers)

Assy No 67295

Item	Part No.	Description	Qty.	Remarks
111				
112	RPS568	Chain Tensioner	1	
113	RPS569	15T 3/4"Pitch Sprocket c/w Bearing	1	
114				
115	SLFE25	Bearing	8	
116				
117				
118	SS040011/006	Steel Spacer	4	
119				
120				
121				
122	W0111	Ø55 Internal Circlip	4	
123	W0113	Ø47 Internal Circlip	2	
124				
125	H105A	Ø4 'R' Clip	2	
126				
127	32600	Push Button (red)	2	
128	67146	Emergency Stop Button	2	
129				
130				
		<b>Hydraulic Components Consist Of:</b>		
135	11124	1/2"BSP Dowty Seal	4	
136	11125	3/8"BSP Dowty Seal	6	
137				
138	12315	1/2"BSP M M Adaptor	4	
139				
140	31167	M22 Dowty Seal	3	
141	31168	M22x1/2"BSP M M Adaptor	3	
142				
143	60795	1/2"Hose Assembly (5460mm)	2	
144	60972	1/2"Hose Assembly (3200mm)	2	
145				
146	RPGMB92.03282	Speed Control Valve	1	
147	RPH405.306981	1/2"Hose Assembly (1630mm)	1	
148	60971	1/2"Hose Assembly (2400mm)	1	
149	27814	1/2"Hose Assembly (2400mm)	1	
150	RPH405.306984	1/2"Hose Assembly (1410mm)	1	
151	RPH700.110608	3/8"BSPx1/2"BSP M M Adaptor	6	
152	RPH724.110808	1/2"BSP M F M Tee	1	
153	RPH888.302717	Control Block	1	
154	RPM225.306985	Mounting Plate	1	
155				
	<b>27200</b>	<b>Roller Assembly Consists Of:</b>		
165	0000300504	Felt Seal	2	
166	27201	Spindle	1	
167	6005RS	Bearing	2	
168	PH408	Seal	2	
169	PH77AR	Ø90 Plain Rubbered Roller	1	
170	PS843	Circlip	2	





Machines from Serial No QM154

**Easi-pic Canopy (4 pickers)**  
Assy No 67297

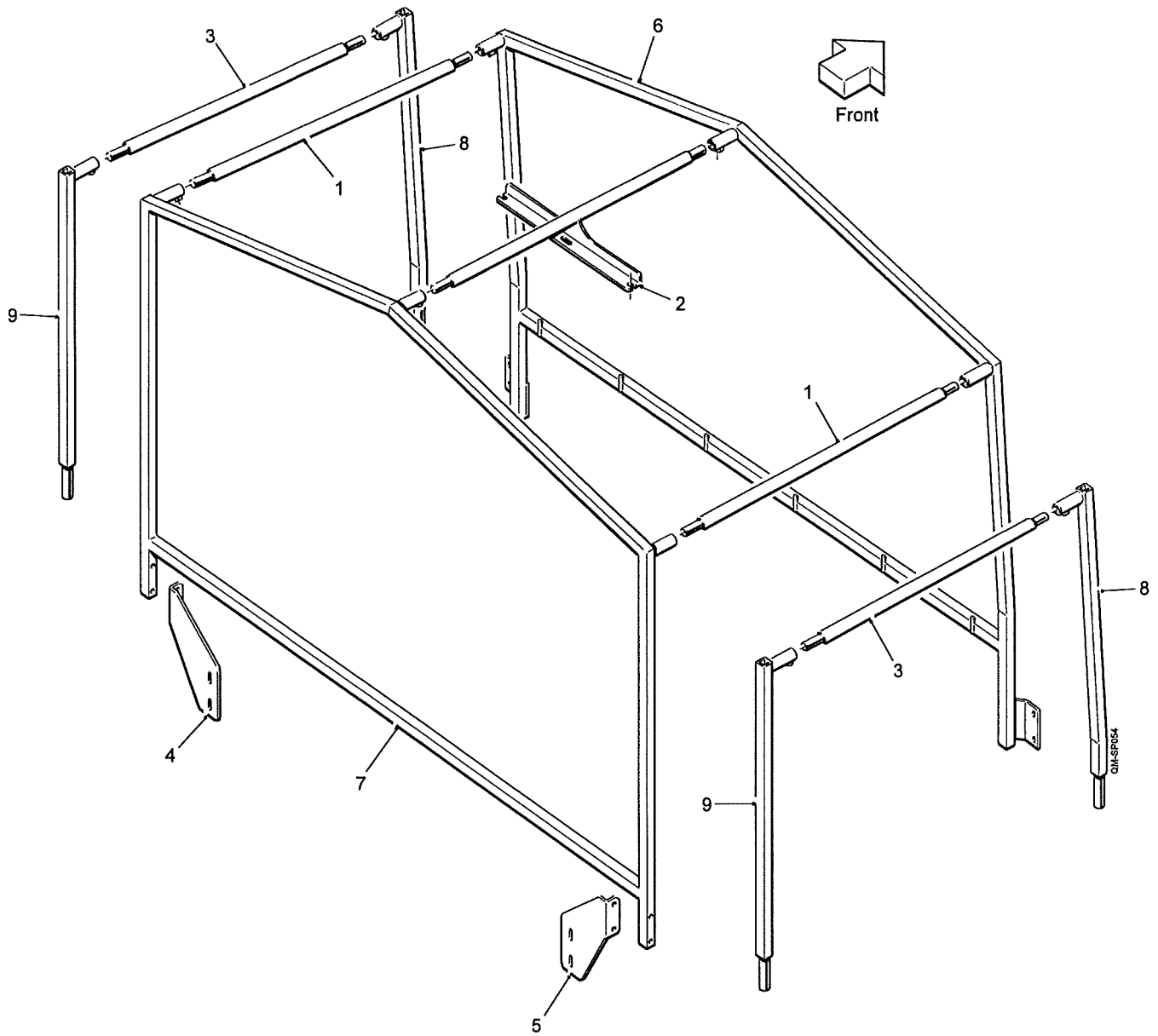

**8.10a****QUALITY MASTER SPARE PARTS**

Machines from Serial No QM154

**Easi-pic Canopy (4 pickers)****Assy No 67297**

Item	Part No.	Description	Qty.	Remarks
1	67191B	Cross Tube (inner)	2	
2	67191C	Cross Tube (centre)	1	
3	67191D	Cross Tube (outer)	2	
4	67288	Mounting Plate LH	1	
5	67289	Mounting Plate RH	1	
6	67291	Canopy Frame Front	1	
7	67292	Canopy Frame Rear	1	
8	67293	Support Leg Front	2	
9	67294	Support Leg Rear	2	
10	67296	Canopy Cover	1	(not shown)

Machines from Serial No QM154

**Sweeping Clod Fingers**  
Assy No 67211

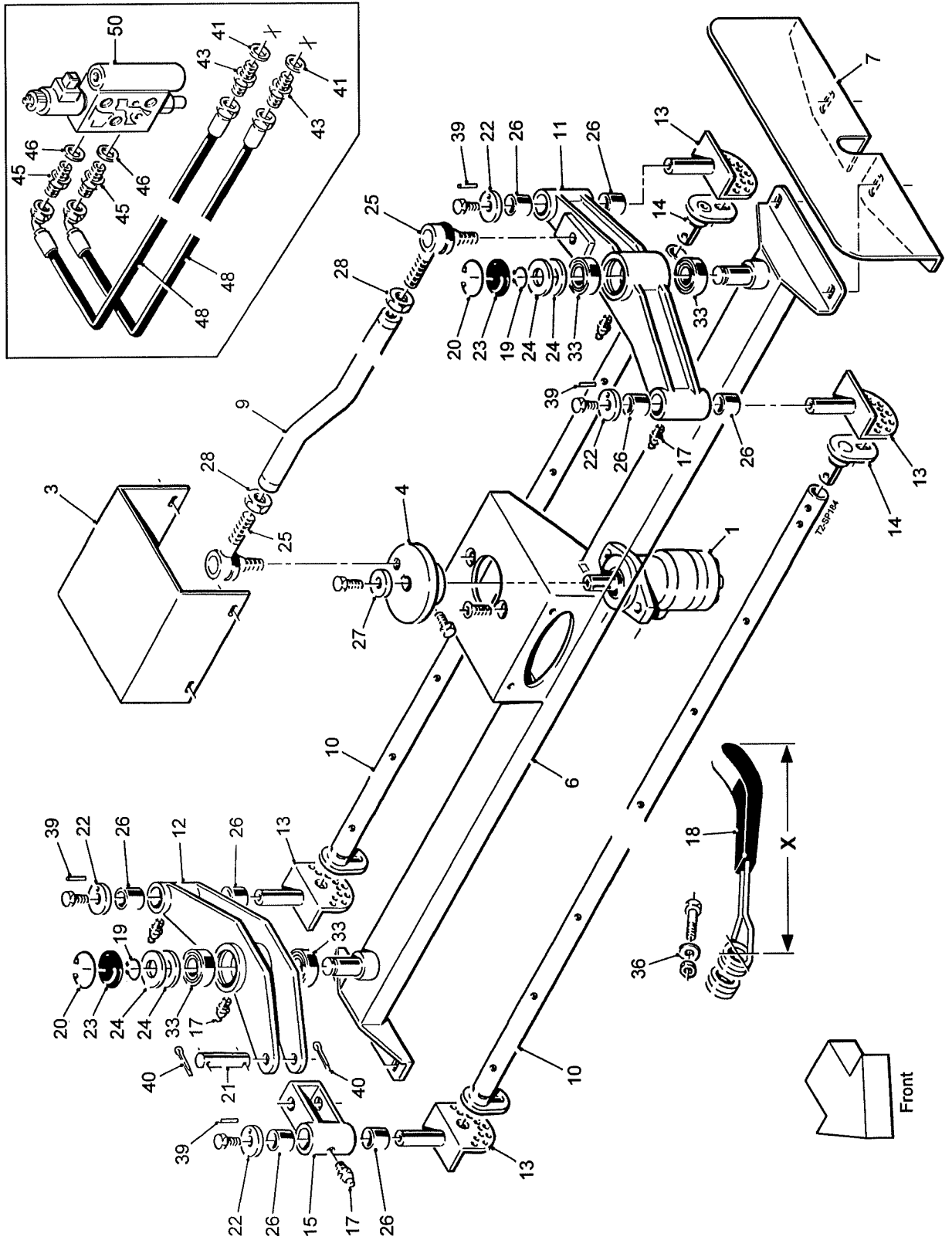

**8.11a****QUALITY MASTER SPARE PARTS**

Machines from Serial No QM154

**Sweeping Clod Fingers**

Assy No 67211

Item	Part No.	Description	Qty.	Remarks
1	44563	Hydraulic Motor	1	
2				
3	56823	Guard	1	
4	56824	Cam	1	
5				
6	67210	Mounting Beam	1	
7	59798	Finger Guard	2	
8				
9	RPA610.301139	Tube	1	
10	67212	Tube	2	
11	RPA610.301165	Oscillator Arm	1	
12	RPA610.301202	Oscillator Arm	1	
13	RPA610.301207	Quadrant Plate	4	
14	RPA610.301209	End Plate	2	
15	RPA610.306023	Hinge Piece	1	
16	RPC632.301869	Decal	1	(not shown)
17	RPC648.081250	M8 Straight Grease Nipple	6	
18	RPC700.304701	Oscillator Paddle	14	
19	RPF200.030200	Ø30 External Circlip	2	
20	W0111	Ø55 Internal Circlip	2	
21	RPGM031.00228	Pin	1	
22	RPGM065.00073	Brass Washer	4	
23	RPGM088.00005	Plastic Dust Cap	2	
24	RPGM088.00017	Sealing Ring	4	
25	RPGMB89.02017	M20 Ball Joint	2	
26	RPM148.302182	Brass Bush	8	
27	RPM196.300869	Washer	1	
28	RPF174.220000	M20 Half Nut	2	
29				
30				
31				
32				
33	6006RS	Bearing	4	
34				
35				
36	SS030011/005	Steel Spacer	14	
37				
38				
39	22067005/010	Ø5x10 Roll Pin	4	
40	22078005/025	Ø5x25 Split Pin	2	
		<b>Hydraulic Components Consist Of:</b>		
41	11124	1/2"BSP Dowty Seal	2	
42				
43	12315	1/2"BSP M M Adaptor	2	
44				
45	27459	M18x1/2"BSP M M Adaptor	2	
46	27461	M18 Dowty Seal	2	
47				
48	60485	1/2"Hose Assembly (1400mm)	2	
49				
50	57217	S/A Proportional Valve Slice	1	Was RPS360-1

Machines from Serial No QM154

**Galaxy Brush Kits**

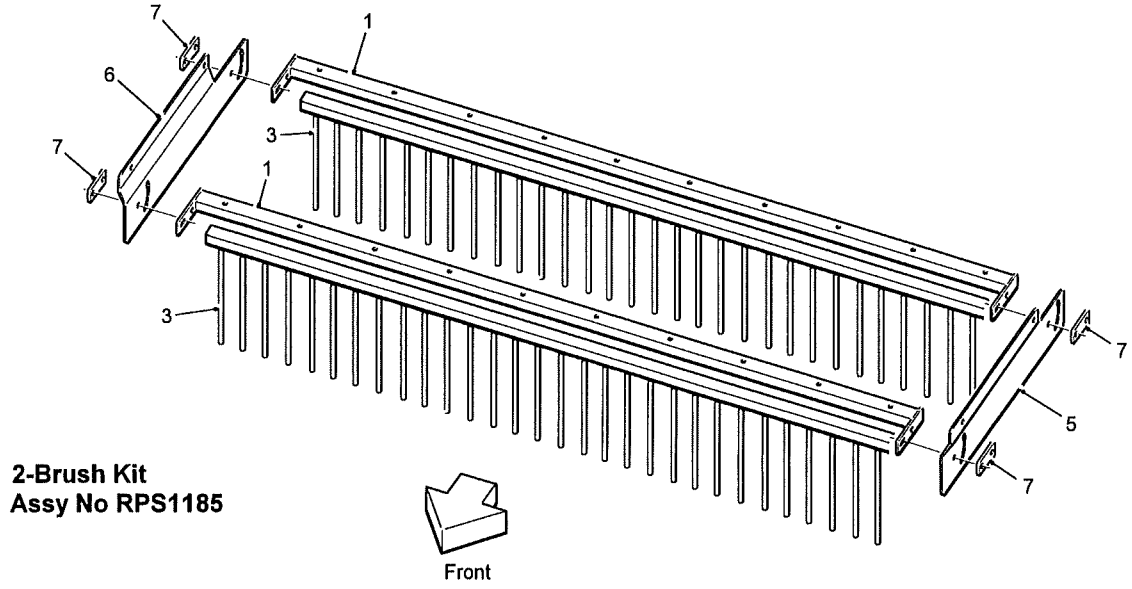

**2-Brush Kit**  
**Assy No RPS1185**

QM-SP055

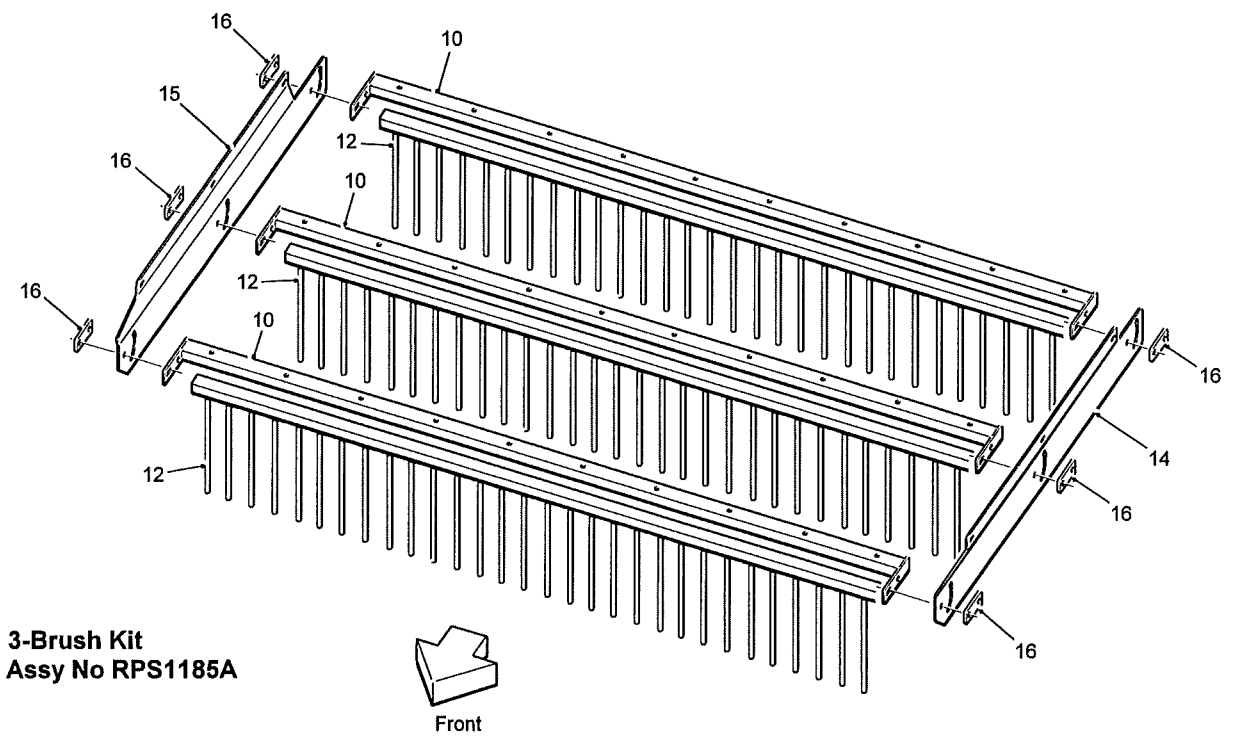

**3-Brush Kit**  
**Assy No RPS1185A**

## 8.12a

## QUALITY MASTER SPARE PARTS

Machines from Serial No QM154

## Galaxy Brush Kits

Item	Part No.	Description	Qty.	Remarks
1	RPS1185	<b>2-Brush Kit Consists Of:</b>		
2	RPA610.309579	Brush Mounting Bar (1500mm)	2	
3	RPRS088.00257	Nylon Brush Strip	2	
4				
5	RPS1182	Mounting Panel LH	1	
6	RPS1183	Mounting Panel RH	1	
7	RPS1184	Tapped Adjuster Plate	4	
10	RPS1185A	<b>3-Brush Kit Consists Of:</b>		
11	RPA610.309579	Brush Mounting Bar (1500mm)	3	
12	RPRS088.00257	Nylon Brush Strip	3	
13				
14	RPS1182A	Mounting Panel LH	1	
15	RPS1183A	Mounting Panel RH	1	
16	RPS1184	Tapped Adjuster Plate	6	

Machines from Serial No QM154

**Braked Axle Assembly**

Assy No 67388

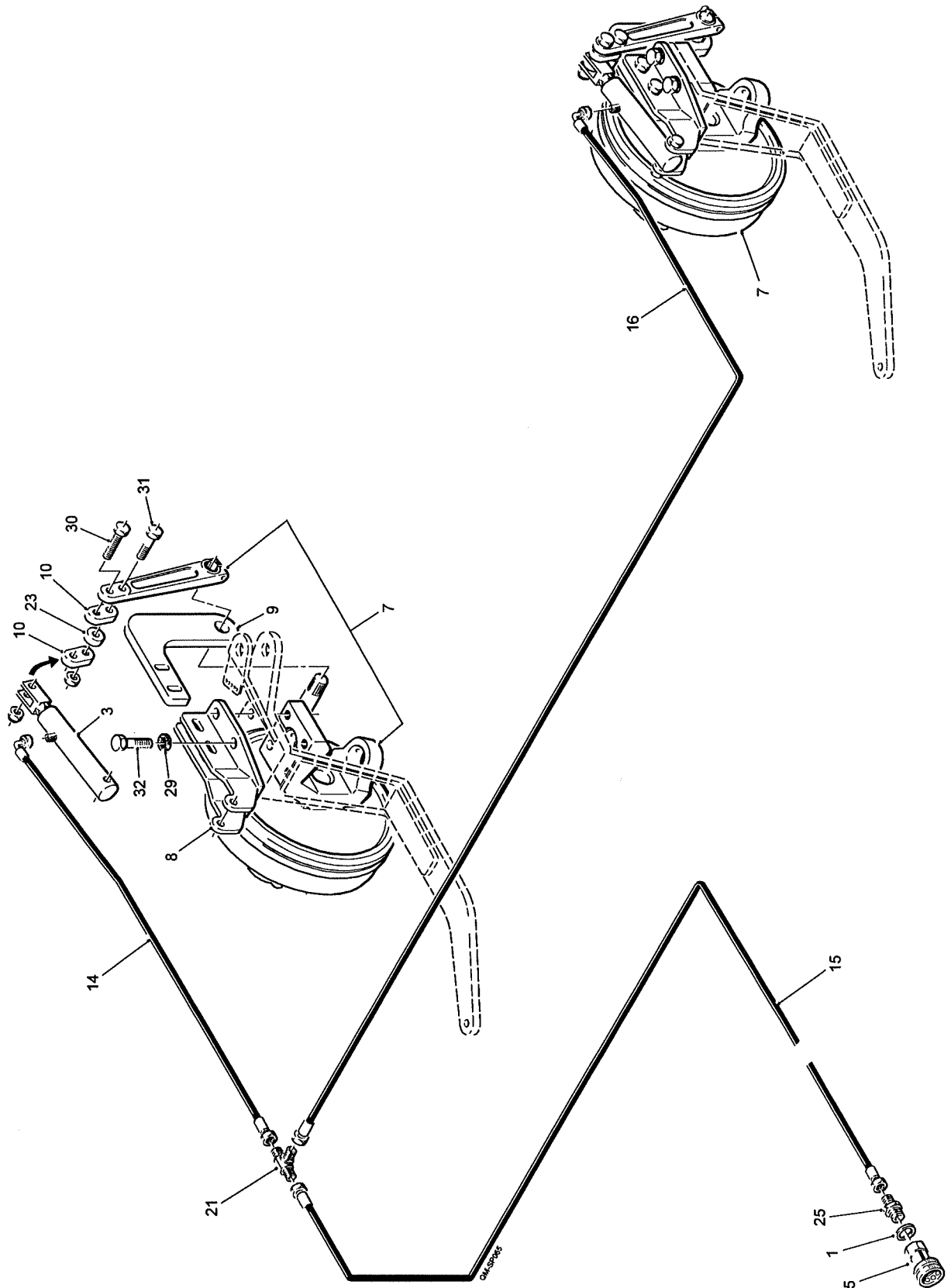

**8.13a****QUALITY MASTER SPARE PARTS**

Machines from Serial No QM154

**Braked Axle Assembly****Assy No 67388**

Item	Part No.	Description	Qty.	Remarks
1	11124	1/2"BSP Dowty Seal	1	
2				
3	57345	Brake Ram	2	
4				
5	60342	1/2"BSP Trail Brake Carrier	1	
6				
7	67382	Braked Stub Axle Assembly	2	
8	67384	Ram Mounting	2	
9	67385	Brake Shaft Support	2	
10	67387	Clevis Plate	4	
11				
12				
13				
14	71020	3/8"Hose Assembly (1400mm)	1	
15	71021	3/8"Hose Assembly (8100mm)	1	
16	71022	3/8"Hose Assembly (3900mm)	1	
17				
18				
19				
20				
21	SPCL597	3/8"BSP M M M Tee	1	
22				
23	SS030013/010	Steel Spacer	2	
24				
25	UC25	1/2"BSPx3/8"BSP M M Adaptor	1	
26				
27				
28				
29	22121016	M16 Nordlock Washer	8	
30	22011012/070	M12x70 Setscrew	2	
31	22012012/060	M12x60 Bolt	2	
32	22126016/055	M16x55 Bolt	8	